

20

23

GENERAL CATALOGUE

Catalogo
generale

CERAMICHE
SUPERGRES

20
23

GENERAL CATALOGUE

**Catalogo
generale**

CERAMICHE
SUPERGRES

Da 60 anni protagonisti del settore ceramico

A major player in the ceramics sector for 60 years

ESPERIENZA E INNOVAZIONE, LE BASI DEL SUCCESSO DELL'AZIENDA

Con 60 anni di esperienza nel settore ceramico e l'appartenenza al Gruppo Concorde, leader nella produzione del settore, Ceramiche Supergres è riuscita a interpretare negli anni il gusto e le necessità dei clienti e a leggere le tendenze del mercato, plasmando prodotti ceramici con un design e una qualità squisitamente made in Italy.

EXPERIENCE AND INNOVATION, THE FOUNDATIONS FOR THE COMPANY'S SUCCESS

With 60 years of experience in the ceramic sector and belonging to the Concorde Group, a leading manufacturer in the sector, Ceramiche Supergres has managed to interpret the tastes and needs of its customers over the years and to understand market trends, shaping ceramic products with exquisitely Made-in-Italy design and quality.



1961

Nasce Supergres.
Supergres is established.

1996

Ingresso nel Gruppo Concorde.
Becomes part of the Concorde Group.

1997

Inizia la produzione di gres porcellanato.
Production of porcelain stoneware begins.

1999

Produzione di rivestimenti in pasta bianca.
in grandi formati
Production of white-body wall tiles in large sizes.

2009

Primi agli Award Ecohitech con il progetto A.I.R.
First classified at the Ecohitech Awards with the A.I.R. project containing pre-consumer recycled material.

2013

Lancio del progetto T20.
Launch of the T20 project.

Nuovo polo logistico.
New logistics hub.

2018

Avvio della produzione di grandi lastre da rivestimento in gres porcellanato.
Start of production of large 6 mm porcelain stoneware slabs.

Podio nella classifica di Panorama, "aziende con il miglior servizio clienti".
Podium in Panorama's "companies with the best customer service" ranking.

2021

Ampliamento showroom.
Showroom expansion.

2023

Oltre 60 anni di successi.
Over 60 years of success.



Headquarter - Casalgrande (RE)



Depuis 60 ans, au premier rang dans le domaine de la céramique

EXPÉRIENCE ET INNOVATION, LES BASES DU SUCCÈS DE L'ENTREPRISE

Avec ses 60 ans d'expérience dans le domaine de la céramique et l'appartenance au groupe Concorde, leader de la production dans le secteur, Ceramiche Supergres a su interpréter au fil des années le goût et les nécessités des clients et lire les tendances du marché en modelant des produits céramiques selon un design et une qualité exclusivement italiens.

Seit 60 Jahren ein Wichtiger akteur in der Keramikbranche

ERFAHRUNG UND INNOVATION SIND DIE GRUNDLAGE FÜR DEN ERFOLG DES UNTERNEHMENS

Mit 60 Jahren Erfahrung im Keramiksektor und der Zugehörigkeit zur Concorde-Group, einem der führenden Hersteller in diesem Bereich, ist es Ceramiche Supergres gelungen, den Geschmack und die Bedürfnisse seiner Kunden im Laufe der Jahre zu interpretieren und die Markttrends zu erkennen, um Keramikprodukte mit einem Design und einer Qualität zu gestalten, die in Italien hergestellt werden.



Showroom - Casalgrande (RE)

Diamo forma e funzione alla materia, vita alle idee

We give form and function to matter, life to ideas

RICERCA E INNOVAZIONE TECNOLOGICA PER PRODUZIONI D'ECCELLENZA

L'atto di creare qualcosa di nuovo in Supergres è la sintesi di un processo che nasce dall'elaborazione di progetti originali, interpretando manufatti del vivere quotidiano o riproducendo l'estetica e le sensazioni dei materiali naturali.

Un lavoro continuo di ricerca, aggiornamento e innovazione tecnologica, per garantire collezioni qualitativamente ed esteticamente all'avanguardia.

RESEARCH AND TECHNOLOGICAL INNOVATION FOR PRODUCTION EXCELLENCE

The creation of something new at Supergres is the synthesis of a process that comes from developing original designs, interpreting artefacts of everyday life or reproducing the aesthetics and feelings of natural materials.

A continuous work of research, updating and technological innovation, to guarantee collections that are qualitatively and aesthetically at the forefront.



Nous donnons forme et fonction à la Matière, vie aux idées

RECHERCHE ET INNOVATION TECHNOLOGIQUE POUR DES PRODUCTIONS D'EXCELLENCE

Chez Supergres, l'acte de créer quelque chose de nouveau est la synthèse d'un processus issu de l'élaboration de projets originaux en interprétant des produits de la vie quotidienne ou en reproduisant l'esthétique et les sensations des matières naturelles.

Un travail continu de recherche, mise à jour et innovation technologique, qui vise à garantir des collections qualitativement et esthétiquement à l'avant-garde.

Wir geben der Materie Form und Funktion, den Ideen Leben

FORSCHUNG UND TECHNOLOGISCHE INNOVATION FÜR EINE HERVORRAGENDE PRODUKTION

Das Schaffen von etwas Neuem bei Supergres ist die Synthese eines Prozesses, der aus der Entwicklung von Originaldesigns, der Interpretation von Artefakten des täglichen Lebens oder der Reproduktion der Ästhetik und der Empfindungen von natürlichen Materialien entsteht.

Eine kontinuierliche Arbeit der Forschung, Aktualisierung und technologischen Innovation, um qualitativ und ästhetisch avantgardistische Kollektionen zu garantieren.

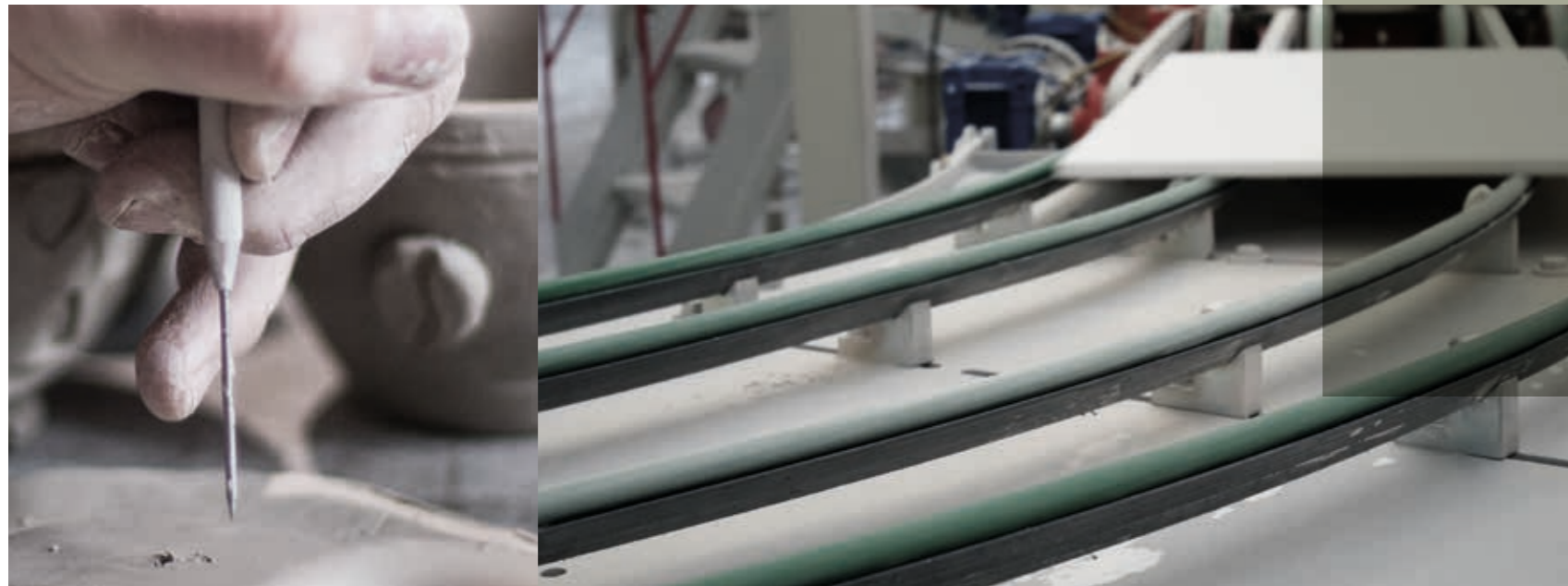

Dall'ispirazione alla sperimentazione, sempre al passo con le tendenze

From inspiration to experimentation, always keeping up with the trends

UNA SOLUZIONE PER OGNI PROGETTO

In Ceramiche Supergres ogni singola collezione è riconoscibile dalle altre, ha una sua identità ed esprime per estetica, scelta dei colori e completezza di gamma, le tante possibilità che l'azienda offre ai suoi clienti in termini di ambienti, stili e destinazioni d'uso differenti. Supergres studia e realizza infatti prodotti in grado di soddisfare ogni esigenza progettuale, dando forma agli ambienti immaginati dai clienti, con gusto, originalità e quel tocco creativo tipico del design italiano.

A DEDICATED SOLUTION FOR EVERY PROJECT

At Ceramiche Supergres every single collection is recognisable from the others, has its own identity and expresses in terms of aesthetics, choice of colours and completeness of range the many possibilities the company offers its customers in terms of different settings, styles and uses. Supergres designs and manufactures products capable of satisfying every design requirement, shaping the environments imagined by customers, with taste, originality and that creative touch typical of Italian design.



+
2.000
PRODOTTI
ITEMS

+
250
COLORI
COLOURS

85
FORMATI
SIZES

70
STRUTTURE
SUPERFICIALI
SURFACE
STRUCTURES

▼
▲
**DIVERSI SPESSORI
PIU' DESTINAZIONI
D'USO**
DIFFERENT
THICKNESSES
MULTIPLE USES



De l'inspiration à l'expérimentation, toujours selon les tendances

UNE SOLUTION POUR CHAQUE PROJET

Chez Ceramiche Supergres, chaque collection se distingue des autres, elle a son identité et exprime, par son esthétique, le choix des couleurs et l'exhaustivité de la gamme, les nombreuses possibilités que l'entreprise propose à ses clients en termes d'espaces, de styles et de variété d'usage prévu. Supergres étudie et réalise en effet des produits qui sont en mesure de répondre à toutes les exigences conceptuelles, en donnant leur forme aux espaces imaginés par les clients, avec goût, originalité et cette touche de créativité qui caractérise le design italien.

Von der Inspiration bis zum Experimentieren, immer im Trend

EINE LÖSUNG FÜR JEDES PROJEKT

Bei Ceramiche Supergres ist jede einzelne Kollektion von den anderen zu unterscheiden, hat ihre eigene Identität und drückt in Bezug auf Ästhetik, Farbauswahl und Vollständigkeit des Angebots die vielen Möglichkeiten aus, die das Unternehmen seinen Kunden in Bezug auf verschiedene Umgebungen, Stile und Verwendungszwecke bietet. Supergres entwirft und fertigt Produkte, die allen Designansprüchen gerecht werden und den von den Kunden erdachten Umgebungen mit Geschmack, Originalität und dem für das italienische Design typischen kreativen Touch Gestalt verleihen.





Identità nazionale, orientamento mondiale

National identity, world orientation

IL MADE IN ITALY CHE FA LA DIFFERENZA

Ceramiche Supergres è orgogliosa di produrre piastrelle in Italia, sia per i valori di stile, design e qualità che esso comporta, sia per il modo Italiano di produrre, rispettoso dei lavoratori, della salute e dell'ambiente.

Ceramiche Supergres ha aderito con convinzione al "Codice Etico" proposto da Confindustria Ceramica che ci impegna a comunicare con chiarezza l'origine dei nostri prodotti, indicando come paese d'origine quello in cui viene effettuata la fase di cottura delle piastrelle che è la fase più importante del processo produttivo, garantendo in questo modo il massimo rispetto e trasparenza verso i clienti e i consumatori finali.

Chi acquista le nostre ceramiche "Made in Italy" può essere certo che esse sono prodotte in Italia, che vengono utilizzate materie prime sicure e realizzate da maestranze qualificate con tecnologie all'avanguardia che rispettano l'ambiente e assicurano le migliori condizioni di lavoro.

Per questo scrivere "Made in Italy" sui nostri prodotti non è per noi uno slogan commerciale ma una espressione di valori forti ispirato alla onestà, all'etica e al senso di responsabilità.

THE MADE IN ITALY THAT MAKES THE DIFFERENCE

Ceramiche Supergres is proud to produce tiles in Italy, both for the values of style, design and quality that it implies, and for the Italian way of production, respectful of workers, health and the environment.

Ceramiche Supergres has firmly adhered to the "Code of Conduct" proposed by Confindustria Ceramica, which commits us to clearly communicate the origin of our products. Indicating as the country of origin the country in which the firing stage of the tiles - which is the most important stage of the production process - takes place, ensures maximum respect and transparency towards customers and end consumers.

Those who buy our "Made in Italy" ceramic tiles can be sure that they are produced in Italy, that safe raw materials are used and that they are made by qualified workers using state-of-the-art technologies that respect the environment and ensure the best working conditions.

Writing 'Made in Italy' on our products is not a commercial slogan for us rather an expression of strong values inspired by honesty, ethics and a sense of responsibility.





Identité nationale, orientation mondiale

LE MADE IN ITALY QUI FAIT LA DIFFÉRENCE

Ceramiche Supergres est fière de produire des carreaux en Italie, aussi bien pour les valeurs de style, design et qualité que cela comporte, que pour la manière italienne de produire, respectueuse des travailleurs, de la santé et de l'environnement.

Ceramiche Supergres a adopté avec conviction le « Code éthique » proposé par Confindustria Ceramica, qui nous engage à communiquer clairement l'origine de nos produits, en indiquant comme pays d'origine le pays où la phase de cuisson des carreaux a lieu ; il s'agit en effet de la phase la plus importante du processus de fabrication, et cela garantit le plus grand respect et la meilleure transparence à l'égard des clients et des consommateurs finaux.

Les personnes qui choisissent nos céramiques « Made in Italy » ont la certitude qu'elles sont fabriquées en Italie, que les matières premières utilisées sont sûres et réalisées par des artisans qualifiés à l'aide de technologies d'avant-garde qui respectent l'environnement et assurent les meilleures conditions de travail.

C'est la raison pour laquelle mentionner « Made in Italy » sur nos produits n'est pas un slogan commercial pour nous, mais l'expression de valeurs fortes, qui s'inspirent de l'honnêteté, de l'éthique et du sens de responsabilité.

Nationale Identität, Weltorientierung

DAS MADE IN ITALY, DAS DEN UNTERSCHIED MACHT

Ceramiche Supergres ist stolz darauf, Fliesen in Italien zu produzieren, sowohl wegen der damit verbundenen Werte wie Stil, Design und Qualität als auch wegen der italienischen Produktionsweise, bei der die Arbeiter, die Gesundheit und die Umwelt respektiert werden.

Ceramiche Supergres hat sich fest an den von der Confindustria Ceramica vorgeschlagenen „Ethikkodex“ gehalten, der uns dazu verpflichtet, die Herkunft unserer Produkte klar zu kommunizieren und als Herkunftsland das Land anzugeben, in dem die Platten gebrannt werden, was die wichtigste Phase des Produktionsprozesses ist, um so ein Höchstmaß an Respekt und Transparenz gegenüber Kunden und Endverbrauchern zu gewährleisten.

Wer unsere „Made in Italy“-Keramik kauft, kann sicher sein, dass sie in Italien hergestellt wird, dass sichere Rohstoffe verwendet werden und dass sie von qualifizierten Arbeitern mit modernsten Technologien hergestellt wird, die die Umwelt respektieren und die besten Arbeitsbedingungen gewährleisten.

Deshalb ist der Schriftzug „Made in Italy“ auf unseren Produkten für uns kein Werbeslogan, sondern Ausdruck starker Werte, die von Ehrlichkeit, Ethik und Verantwortungsbewusstsein geprägt sind.





Persone e valori Prima di tutto

People and values first

SERietà, TRASPARENZA E AFFIDABILITÀ LA GARANZIA DEL NOSTRO IMPEGNO

Un legame forte unisce l'azienda, i dipendenti, i collaboratori e fornitori locali. La storia di Ceramiche Supergres racconta di persone che trovano soddisfazione all'interno di un'azienda che crede nella crescita, cerca il miglioramento e ha massima fiducia nel futuro.

Ogni individuo ha qualcosa di unico da offrire che, nel lavoro di squadra, permette al team di raggiungere con passione, affiatamento, trasparenza e affidabilità, lo stesso obiettivo.

SERIOUSNESS, TRANSPARENCY AND RELIABILITY ARE THE GUARANTEE OF OUR COMMITMENT

A strong bond unites the company, its employees, collaborators and local suppliers. The story of Ceramiche Supergres tells of people who find satisfaction within a company that believes in growth, seeks improvement and has the utmost confidence in the future.

Each single person has something unique to offer which - in teamwork - enables the team to achieve the same goal with passion, fellowship, transparency and reliability.



ECCELLENZA
EXCELLENCE

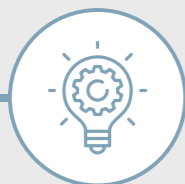

INNOVAZIONE
INNOVATION



ENTUSIASMO
ENTHUSIASM

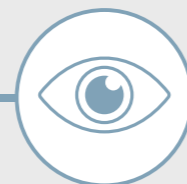

ESTETICA
AESTHETICS



DESIGN
DESIGN



COMPETENZA
EXPERTISE



AFFIDABILITÀ
RELIABILITY



QUALITÀ
QUALITY

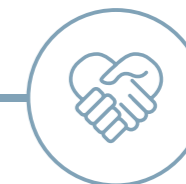

RISPETTO
RESPECT



Les personnes et les valeurs avant tout

SÉRIEUX, TRANSPARENCE ET FIABILITÉ SONT LA GARANTIE DE NOTRE ENGAGEMENT

Un lien fort unit l'entreprise, les employés, les collaborateurs et les fournisseurs locaux. L'histoire de Ceramiche Supergres parle de personnes qui trouvent leur satisfaction au sein d'une entreprise qui croit en la croissance, cherche l'amélioration et nourrit la plus grande confiance à l'égard du futur.

Chaque individu a quelque chose d'unique à offrir qui, dans le travail d'équipe, permet au groupe d'atteindre un même objectif avec passion, harmonie, transparence et fiabilité.

Menschen und Werte an erster stelle

VERBINDLICHKEIT, TRANSPARENZ UND ZUVERLÄSSIGKEIT SIND DIE GARANTIE FÜR UNSER ENGAGEMENT

Eine starke Gebundenheit charakterisiert das Unternehmen, seine Beschäftigten, Mitarbeiter und lokalen Lieferanten. Die Geschichte von Ceramiche Supergres erzählt von Menschen, die ihre Zufriedenheit in einem Unternehmen finden, das an Wachstum glaubt, nach Verbesserungen strebt und größtes Vertrauen in die Zukunft hat.

Jeder Einzelne hat etwas Einzigartiges zu bieten, das es dem Team ermöglicht, mit Leidenschaft, Kameradschaft, Transparenz und Zuverlässigkeit das gleiche Ziel zu erreichen.

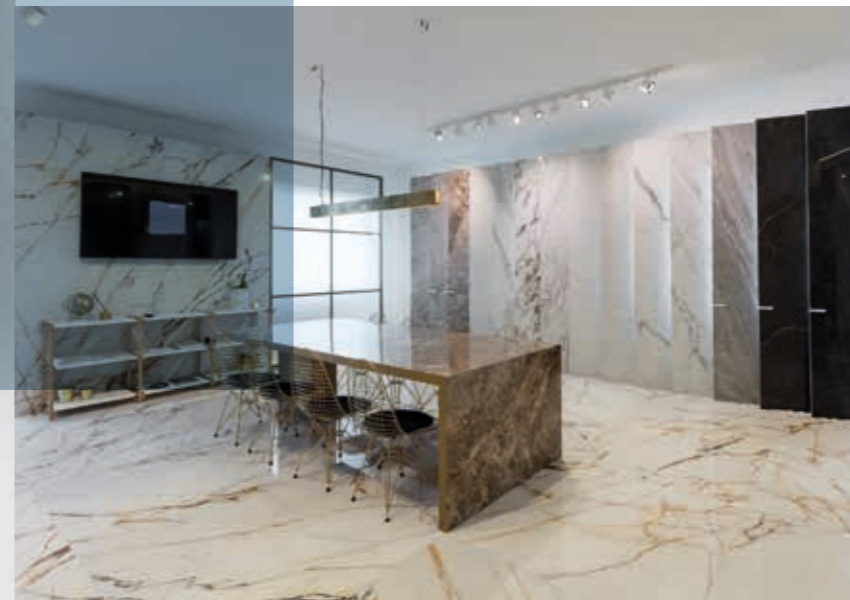

Verso un design consapevole, un'architettura sostenibile

Towards conscious design and sustainable architecture

CERAMICA GREEN

Per Supergres il design contemporaneo è in sintonia con l'ambiente, l'unico a non passare di moda. Operare in armonia con la natura significa rispettare l'equilibrio ambientale, cercando di conservarlo immutato e ove possibile di arricchirlo.

Supergres si impegna su questo fronte da anni nello sviluppo di sistemi di produzione green, per un ambiente in equilibrio, un mondo sostenibile.

GREEN CERAMICS

At Supergres, contemporary design is in tune with the environment, the only one that does not go out of fashion. Working in harmony with nature means respecting the balance of the environment, seeking to preserve it and where possible enrich it.

Supergres has been working on this front for years developing green production systems, for a balanced environment and a sustainable world.



100%
RIUTILIZZO
ACQUE REFLUE
WASTEWATER
REUSE



100%
RECUPERO SCARTI
CRUDI E COTTI
RECYCLING OF
UNFIRED AND
FIRED WASTE



COGENERAZIONE
PER IL RISPARMIO
ENERGETICO
COGENERATION
TO SAVE ENERGY



CARTA E PLASTICA
RICICLATA
RECYCLED PAPER
AND PLASTIC



SOLO IL **2%**
SMALTIMENTO
INDIFFERENZIATO
ONLY 2% OF
NON-RECYCLABLE
WASTE



Vers un design responsable, une architecture durablee

CÉRAMIQUE VERTE

Pour Supergres le design contemporain est respectueux de l'environnement, le seul qui ne passe pas de mode. Travailler en harmonie avec la nature, c'est respecter l'équilibre de l'environnement, en tentant de la garder inchangée et, lorsque cela est possible, de l'enrichir.

De ce point de vue Supergres s'engage depuis des années dans le développement de systèmes de production verte, pour un environnement en équilibre et un monde durable.

Für bewusstes Design, nachhaltige Architektur

UMWELTFREUNDLICHE KERAMIK

Für Supergres steht das zeitgenössische Design im Einklang mit der Umwelt, das einzige, das nicht aus der Mode kommt. Im Einklang mit der Natur zu arbeiten bedeutet, das Gleichgewicht der Umwelt zu respektieren, sie zu erhalten und nach Möglichkeit zu bereichern.

Supergres arbeitet seit Jahren an der Entwicklung von grünen Produktionssystemen für eine ausgewogene Umwelt und eine nachhaltige Welt.

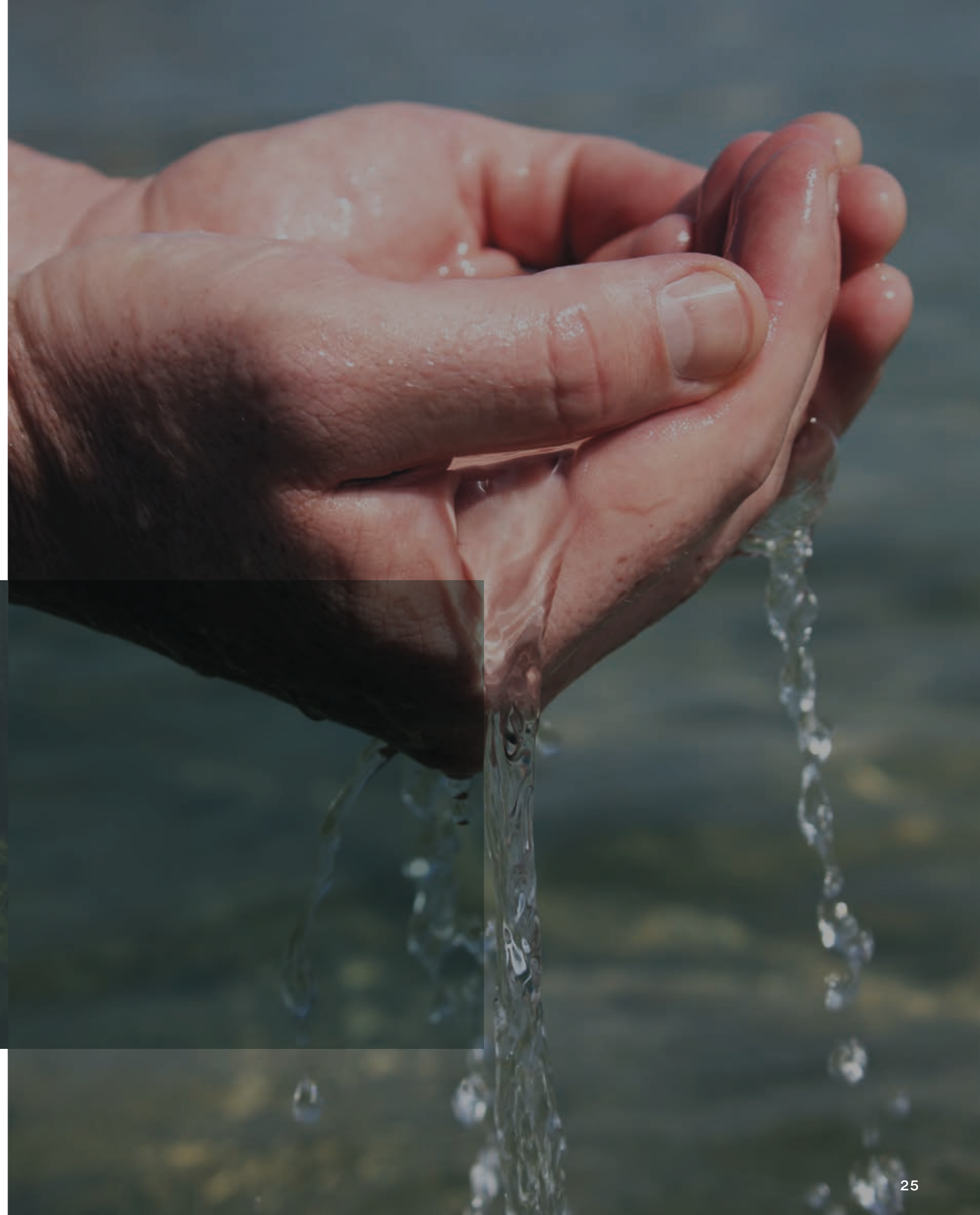
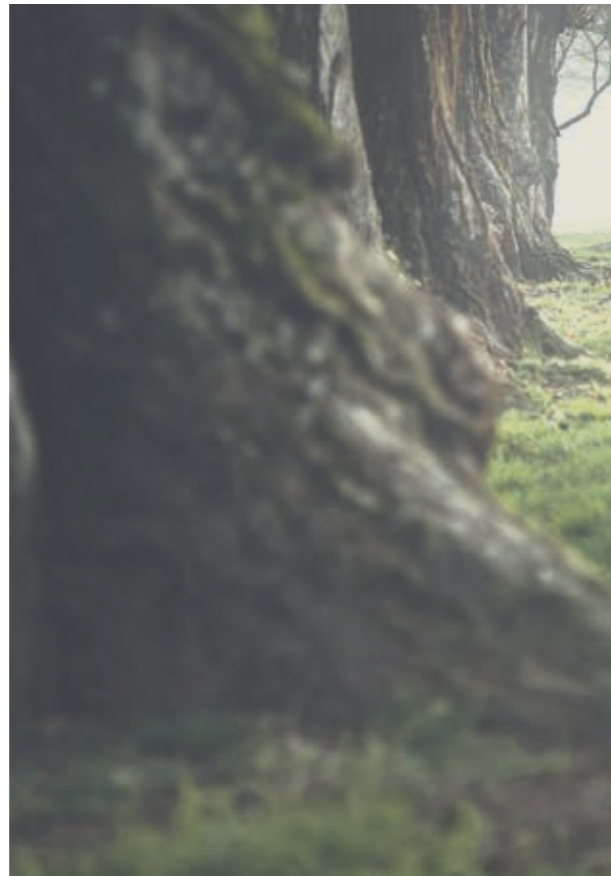

Riduzione dei consumi

Consumption reduction

La totalità delle acque reflue è riutilizzata nel ciclo produttivo, evitando lo spreco di questa preziosa risorsa naturale. Allo stesso tempo impianti all'avanguardia di cogenerazione contribuiscono al fabbisogno energetico, reimpiegando il calore generato in fase di produzione.

All wastewater is reused in the production cycle, avoiding waste of this precious natural resource. At the same time, state-of-the-art cogeneration plants contribute to energy requirements by reusing the heat generated during production.

Recupero scarti

Waste recovery

Le piastrelle non conformi ai nostri standard qualitativi e non ancora cotte vengono macinate e trasformate in nuova materia prima, per essere poi reintrodotta all'interno del processo produttivo. Anche gli scarti cotti, opportunamente trattati, trovano il loro reimpiego. Il recupero degli scarti di produzione riduce la necessità di consumare nuove materie prime, alleggerendo l'impatto ambientale della nostra azienda.

Tiles that do not meet our quality standards and have not been fired yet are ground and transformed into new raw material, to be reintroduced into the production process. Fired waste, properly treated, also finds reuse. The recovery of production waste reduces the need to use new raw materials, easing our company's environmental impact.

Materiali riciclati e riciclabili

Recycled and recyclable materials

La totalità della plastica e carta utilizzata è riciclata e tutti gli imballi sono riciclabili, i pallet conformi alle norme FAO e la carta certificata FSC. Quasi la totalità (il 98%) dei rifiuti aziendali è avviata alla raccolta differenziata.

All plastic and paper used is recycled and all packaging is recyclable, pallets conform to FAO standards and paper is FSC certified. Almost all (98%) of the company waste is collected separately.





Réduction de la consommation

La totalité des eaux usées est réutilisée dans le cycle de production, en évitant le gaspillage de cette ressource naturelle précieuse.

En même temps, les installations d'avant-garde de cogénération contribuent au besoin d'énergie, en réutilisant la chaleur générée en phase de production.

Récupération des déchets

Les carreaux non conformes à nos standards de qualité et qui ne sont pas encore cuits sont broyés et transformés en nouvelle matière première, qui est ensuite réintroduites dans le processus de fabrication.

Les déchets cuits, dûment traités, sont également réutilisés. La récupération des déchets de production réduit la nécessité de consommer de nouvelles matières premières, ce qui allège l'impact de notre entreprise sur l'environnement.

Matériel recyclé et recyclable

La totalité du plastique et du papier utilisés est recyclée, et tous les emballages sont recyclables, les palettes sont conformes aux normes FAO et le papier est certifié FSC. La quasi-totalité (98 %) des déchets de l'entreprise est confiée à la collecte sélective des déchets.

Verbrauchsreduktion

Das gesamte Abwasser wird im Produktionszyklus wiederverwendet, wodurch die Verschwendung dieser wertvollen natürlichen Ressource vermieden wird.

Gleichzeitig tragen modernste Kraft-Wärme-Kopplungsanlagen zur Deckung des Energiebedarfs bei, indem sie die bei der Produktion entstehende Wärme wiederverwenden.

Abfallrückgewinnung

Fliesen, die nicht unseren Qualitätsstandards entsprechen und noch nicht gebrannt wurden, werden gemahlen und zu neuem Rohmaterial verarbeitet, das dann wieder in den Produktionsprozess einfließt.

Auch gekochte Abfälle, die ordnungsgemäß behandelt werden, finden eine Wiederverwendung. Die Rückgewinnung von Produktionsabfällen verringert den Bedarf an neuen Rohstoffen und entlastet damit die Umwelt unseres Unternehmens.

Recycelte und wiederverwertbare Materialien

Alle verwendeten Kunststoffe und Papiere sind recycelt, alle Verpackungen sind wiederverwertbar, die Paletten entsprechen den FAO-Normen und das Papier ist FSC-zertifiziert. Fast alle (98 %) Abfälle des Unternehmens werden getrennt gesammelt.

Numerose certificazioni ambientali, di processo e prodotto, confermano l'impegno di Supergres

Numerous environmental, process and product certifications confirm Supergres commitment

Un grand nombre de certifications environnementales, de processus et de produit, confirme l'engagement de Supergres

Zahlreiche Umwelt-, Prozess- und Produktzertifizierungen bestätigen das Engagement von Supergres

LEED

Leadership in Energy and Environmental Design

Ceramiche Supergres, da sempre molto sensibile alle tematiche dell'edilizia sostenibile, realizza prodotti che consentono di concorrere all'ottenimento di punteggi LEED (Leadership in Energy and Environmental Design), il sistema di parametri nato negli Stati Uniti per valutare l'eco-sostenibilità degli edifici.

Ceramiche Supergres, has always been extremely focused when it comes to sustainable building issues, creating products that are able to achieve LEED (Leadership in Energy and Environmental Design) points, the system of parameters created in the United States to measure the eco-sustainability of buildings.

Ceramiche Supergres, toujours très sensible aux thèmes de la construction durable, réalise des produits qui permettent de participer à l'obtention des points LEED (Leadership in Energy and Environmental Design), le système de paramètres né aux États-Unis pour évaluer l'éco-durabilité des bâtiments.

Ceramiche Supergres, schon immer aufmerksam gegenüber Umweltfragen und Nachhaltigkeit, stellt Produkte her, die zum Erhalt von LEED Punkten (Leadership in Energy and Environmental Design) beitragen, einem Parametersystem aus den USA, das die ökologische Nachhaltigkeit von Gebäuden bewertet.

PEF

Product Environmental Footprint

Introdotta dall'Unione Europea, la PEF è una dichiarazione di conformità del prodotto a determinati criteri ambientali certificati. È una dichiarazione delle performance ambientali del prodotto relative all'intero ciclo di vita.

Introduced by the European Union, PEF is a declaration of conformity of a product in compliance with certain given certified environmental criteria. It is a declaration of the environmental performances of a product in relation to its entire life-cycle.

Introduite par l'Union Européenne, la PEF est une déclaration de conformité du produit à certains critères environnementaux certifiés. C'est une déclaration des performances environnementales du produit relatives à tout le cycle de vie.

Die von der Europäischen Union eingeführte PEF ist eine Deklaration über die Einhaltung bestimmter zertifizierter Umweltkriterien. PEF ist Deklaration über die Umweltverträglichkeit eines Produkts während seines gesamten Lebenszyklus.

FDES

Fiches de Déclaration Environnementale et Sanitaire

Questa dichiarazione introdotta principalmente per il mercato francese, attesta la conformità dei prodotti di Ceramiche Supergres a determinati indicatori e valori di carattere ambientale e sanitario.

This declaration relates exclusively to the French market and certifies the compliance of Ceramiche Supergres products to certain environmental and health indicators. FDES regulations are very popular among architects and construction managers in the French market during the selection phase of the materials.

Cette déclaration concerne exclusivement le marché français et atteste la conformité des produits de Ceramiche Supergres à certains indicateurs et valeurs de caractère environnemental et sanitaire. Sur le marché français, les FDES sont très utilisées par les architectes et par les directeurs des travaux, durant la phase de sélection des matériaux.

Diese Deklaration bezieht sich nur auf den französischen Markt und bescheinigt die Konformität der Produkte von Ceramiche Supergres in Bezug auf ganz bestimmte Indikatoren und Umwelts- und Gesundheitswerte. Auf dem französischen Markt werden die FDES von Architekten und Bauleitern bei der Auswahl der Materialien häufig verwendet.

HPD

Health Product Declaration

Ceramiche Supergres dispone di questa autodichiarazione, diffusa nel mercato americano, che attesta le caratteristiche di ecosostenibilità del prodotto finito.

Ceramiche Supergres adopts this self-declaration, widespread on the American market, which certifies the features of eco-sustainability of a finished product.

Ceramiche Supergres dispose de cette auto-déclaration, diffuse sur le marché américain, qui atteste les caractéristiques d'éco-durabilité du produit fini.

Ceramiche Supergres verfügt über diese, auf dem amerikanischen Markt weit verbreitete Selbstdeklaration, die die Nachhaltigkeit des fertigen Produkts bescheinigt.

DECLARE

Etichetta per la trasparenza dei materiali da costruzione

Sempre attenta ai temi della sostenibilità, Supergres ha deciso di adottare l'etichetta Declare che comunica ai progettisti, al consumatore finale e alle imprese da dove viene il prodotto, come è composto e come può essere smaltito al termine del suo ciclo di vita.

With its eyes permanently trained on the issue of sustainability, Supergres has decided to adopt the Declare label, which communicates to designers, end consumers and companies the origin of the product, what it is made of and how it can be disposed of at the end of its life cycle.

Toujours attentive aux questions de durabilité, Supergres a décidé d'adopter l'étiquette Declare qui communique aux concepteurs, aux consommateurs finals et aux entreprises d'où vient le produit, sa composition et la manière dont il peut être éliminé à la fin de son cycle de vie.

Supergres hat schon immer auf Nachhaltigkeitsaspekte geachtet und man sich jetzt zur Verwendung des Declare-Etiketts entschieden, das Planern, Endverbrauchern und Unternehmen mitteilt, woher das Produkt kommt, woraus es besteht und wie es am Ende seines Lebenszyklus entsorgt werden kann.

WELL

'International WELL® Building Institute (IWBI)

Il sistema di valutazione WELL è un innovativo strumento, su base volontaria, di classificazione e certificazione dell'edificio relativamente alla sua salubrità, al comfort, alla salute e al benessere delle persone che vivono o lavorano al suo interno.

The WELL rating system is an innovative, voluntary tool for classifying and certifying buildings concerning their healthiness and comfort, health and well-being of the people who live or work in them.

Le système d'évaluation WELL est un instrument innovant, sur base volontaire, de classement et de certification des bâtiments en termes de salubrité, de confort, de santé et de bien-être des personnes qui vivent et travaillent à l'intérieur.

Das WELL-Bewertungssystem ist ein innovatives, freiwilliges Instrument zur Klassifizierung und Zertifizierung von Gebäuden im Hinblick auf ihre Gesundheit, ihren Komfort und das Wohlbefinden der Menschen, die in ihnen leben oder arbeiten.

ISO 17889

Sustainability for ceramic tiles and installation materials

Le collezioni di Ceramiche Supergres hanno ottenuto la certificazione ISO 17889. La norma ISO 17889-1:2021 "Sustainability for ceramic tiles and installation materials" definisce uno standard unico e internazionale per valutare la sostenibilità delle piastrelle ceramiche analizzando l'impatto ambientale, economico e sociale dell'intero ciclo di vita, dalle materie prime allo smaltimento, valutando anche condizioni di sicurezza e di salute dei lavoratori.

Ceramiche Supergres collections have been awarded ISO 17889 certification. ISO 17889-1:2021 - Sustainability for ceramic tiles and installation materials - defines a unique, international standard for assessing the sustainability of ceramic tiles by analysing the environmental, economic and social impact of the entire life cycle, from raw materials to disposal, while also assessing health and safety conditions for workers.

Les collections de Ceramiche Supergres ont obtenu la certification ISO 17889. La norme ISO 17889-1:2021 « Sustainability for ceramic tiles and installation materials » est une norme unique et internationale qui évalue la durabilité du carrelage en céramique en analysant l'impact environnemental, économique et social de l'ensemble de son cycle de vie, des matières premières à l'élimination, en évaluant également les conditions de sécurité et de santé des travailleurs.

Die Kollektionen von Ceramiche Supergres sind nach ISO 17889 zertifiziert. ISO 17889-1:2021 „Sustainability for ceramic tiles and installation materials“ definiert eine einzigartige internationale Norm für die Bewertung der Nachhaltigkeit von keramischen Fliesen und Verlegewerkstoffen durch die Analyse der ökologischen, wirtschaftlichen und sozialen Auswirkungen des gesamten Lebenszyklus, von den Rohstoffen bis zur Entsorgung, wobei auch die Gesundheits- und Sicherheitsbedingungen für die Arbeitnehmer bewertet werden.

Per maggiori informazioni consultare il sito www.supergres.com e la pag. 314 di questo catalogo.

To find out more, consult the website www.supergres.com, as well as page 314 of this catalogue.

Pour plus d'informations, consulter le site www.supergres.com, et la page 314 de ce catalogue.

Für weitere Informationen besuchen Sie bitte die Website www.supergres.com und Seite 314 dieses Katalogs.

La sicurezza prima di tutto

Safety first

I nostri prodotti sono privi di sostanze tossiche e non rilasciano contaminanti nell'ambiente quali piombo, fluoro, formaldeide, radon, composti organici volatili o benzilbutilftalati. Ignifughi, in caso di incendio non rilasciano sostanze tossiche o fumi. Sono materiali che naturalmente non favoriscono la proliferazione sulle loro superfici di funghi, muffe e allergeni.

Our products are free of toxic substances and do not release into the environment contaminants such as lead, fluorine, formaldehyde, radon, volatile organic compounds or benzylbutylphthalate. Fireproof, in the event of fire will not release toxic substances or fumes. By their nature these materials do not encourage the proliferation on their surfaces of fungi, moulds and allergens.

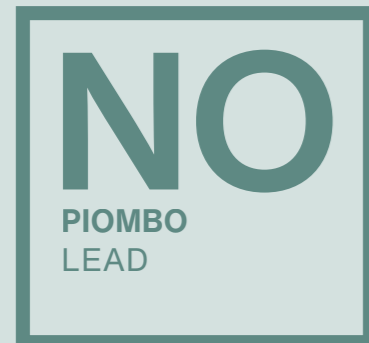

La sécurité avant tout

Nos produits sont dépourvus de substances toxiques et ne dégagent aucun contaminant dans l'environnement, comme le plomb, le fluor, le formaldéhyde, le radon, les composés organiques volatiles et les phtalates de benzylbutyle. Ignifuges, en cas d'incendie ils ne dégagent aucune substance toxique ni fumée. Il s'agit de matériel qui, naturellement, ne favorise pas la prolifération de champignons, moisissures et allergènes sur leurs surfaces.

Sicherheit zuerst

Unsere Produkte sind frei von toxischen Substanzen und geben keine Schadstoffe wie Blei oder Fluor an die Umwelt ab, Formaldehyd, Radon, flüchtige organische Verbindungen oder Benzylbutylphthalate. Feuerfest, gibt im Falle eines Brandes keine giftigen Stoffe oder Dämpfe ab. Es handelt sich um Materialien, die von Natur aus die Vermehrung der folgenden Stoffe auf ihrer Oberfläche nicht fördern Pilze, Schimmel und Allergene.



La ceramica. Una scelta sicura.

Ceramics. A safe choice.

La céramique. Un choix sûr.

Keramik. Eine gute Entscheidung.



IGIENICA

Hygienic
Hygiénique
Hygienisch



SALUBRE

Healthy
Salubre
Nicht Gesundheits-
schädigend



RESISTENTE ALL'USURA

Wear resistant
Résistant à l'usure
Verschleissfest



ANTIMACCHIA

Stain resistant
Anti-taches
Fleckabweisend



INGELIVA

Frostproof
Ingélif
Frostbeständig



VERSATILE

Versatile
Versatile
Vielseitig

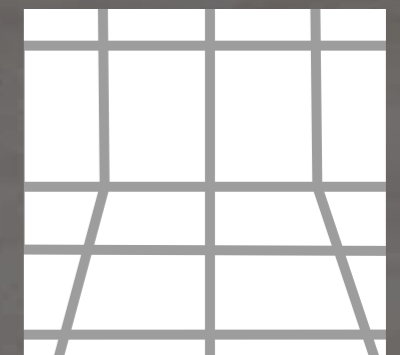

Per maggiori informazioni consultare il sito www.supergres.com e la pag. 336 di questo catalogo.

To find out more, consult the website www.supergres.com, as well as page 336 of this catalogue.

Pour plus d'informations, consulter le site www.supergres.com, et la page 336 de ce catalogue.

Für weitere Informationen besuchen Sie bitte die Website www.supergres.com und Seite 336 dieses Katalogs.

Indice alfabetico

ALPHABETICAL INDEX

ADIGE.....	42	PURITY OF MARBLE.....	164
ADIGE T_20.....	254	PURITY OF MARBLE WALL.....	170
ART.....	48	PURITY OF MARBLE BRECCE.....	176
ART WALL.....	54	PURITY OF MARBLE ELITE.....	182
ART T_20.....	258	PURITY OF MARBLE TUSCANY.....	190
ASTRUM.....	58	STOCKHOLM T_20.....	290
ASTRUM T_20.....	262	STONEWORK.....	196
COAST ROAD.....	68	STONEWORK T_20.....	294
COLOVERS.....	74	STOORM.....	204
COLOVERS WALL.....	82	STORY.....	210
EKHO.....	88	STORY T_20.....	298
EKHO T_20.....	266	TRAVEL.....	216
EPIKA.....	94	TRAVEL T_20.....	302
FORTH.....	100	WALK.....	222
FORTH T_20.....	270	WALK T_20.....	306
FOUR SEASONS / PROFILI.....	246	YOUR MATCH.....	228
FREEDHOME.....	106	YOUR MATCH WALL.....	236
FREEDHOME T_20.....	274	YOUR MATCH PALETTE N.2.....	240
FRENCHMOOD.....	116	YOUR MATCH T_20.....	310
FRENCHMOOD T_20.....	278	T_20	252
H.24.....	120	IL RISPETTO PER L'AMBIENTE	
H.24 WALL.....	124	Eco - sustainability.....	314
H.24 T_20.....	282	CARATTERISTICHE TECNICHE	
HUSK.....	130	Technical characteristics.....	330
MEDLEY WALL.....	140	POSA, PULIZIA E MANUTENZIONE	
MET-ALL WALL.....	142	Laying, cleaning and maintenance.....	340
NATURAL APPEAL.....	148	CONDIZIONI GENERALI DI VENDITA	
OVERTIME.....	154	General sales conditions.....	358
OVERTIME WALL.....	160		
OVERTIME T_20.....	286		

Indice per tecnologia

INDEX BY TECHNOLOGY

Pavimenti in gres porcellanato

Porcelain stoneware floor tiles

ADIGE.....	42
ADIGE T_20.....	254
ART.....	48
ART T_20.....	258
ASTRUM.....	58
ASTRUM T_20.....	262
COAST ROAD.....	68
COLOVERS.....	74
EKHO.....	88
EKHO T_20.....	266
EPIKA.....	94
FORTH.....	100
FORTH T_20.....	270
FREEDHOME.....	106
FREEDHOME T_20.....	274
FRENCHMOOD.....	116
FRENCHMOOD T_20.....	278
H.24.....	120
H.24 T_20.....	282
HUSK.....	130
NATURAL APPEAL.....	148
OVERTIME.....	154
OVERTIME T_20.....	286
PURITY OF MARBLE.....	164
PURITY OF MARBLE BRECCE.....	176
PURITY OF MARBLE ELITE.....	182
PURITY OF MARBLE TUSCANY.....	190
STOCKHOLM T_20.....	290
STONEWORK.....	196
STONEWORK T_20.....	294
STOORM.....	204
STORY.....	210
STORY T_20.....	298
TRAVEL.....	216
TRAVEL T_20.....	302
WALK.....	222
WALK T_20.....	306
YOUR MATCH.....	228
YOUR MATCH T_20.....	310

Rivestimenti in pasta bianca

White body wall tiles

ART WALL.....	54
COLOVERS WALL.....	82
H.24 WALL.....	124
MEDLEY WALL.....	140
MET-ALL WALL.....	142
OVERTIME WALL.....	160
PURITY OF MARBLE WALL.....	170
YOUR MATCH WALL.....	236
YOUR MATCH PALETTE N.2.....	240

Indice per tipologia

INDEX BY EFFECT

EFFETTO CEMENTO

Concrete effect

ART	48
ART WALL	54
H.24	120
H.24 WALL	124
YOUR MATCH	228
YOUR MATCH WALL	236
YOUR MATCH PALETTE N.2	240

EFFETTO DESIGN

Design effect

COLOVERS	74
COLOVERS WALL	82
MEDLEY WALL	140
MET-ALL WALL	142

EFFETTO LEGNO

Wood effect

EKHO	88
FREEDHOME	106
HUSK	130
NATURAL APPEAL	148
TRAVEL	216

EFFETTO MARMO

Marble effect

PURITY OF MARBLE	164
PURITY OF MARBLE WALL	170
PURITY OF MARBLE BRECCE	176
PURITY OF MARBLE ELITE	182
PURITY OF MARBLE TUSCANY	190

EFFETTO PIETRA

Stone effect

ADIGE	42
ASTRUM	58
COAST ROAD	68
EPIKA	94
FRENCHMOOD	116
FORTH	100
OVERTIME	154
OVERTIME WALL	160
STONWORK	196
STOORM	204
STORY	210
WALK	222

MOSAICI E PROFILI ABBINABILI A TUTTE LE SERIE

Mosaics and profiles
to match all series

FOUR SEASONS	246
MOSAICI E PROFILI	250

T_20

EFFETTO CEMENTO

Concrete effect

ART T_20	258
H.24 T_20	282
YOUR MATCH T_20	310

EFFETTO LEGNO

Wood effect

EKHO T_20	266
FREEDHOME T_20	274
TRAVEL T_20	302

EFFETTO PIETRA

Stone effect

ADIGE T_20	254
ASTRUM T_20	262
FORTH T_20	270
FRENCH MOOD T_20	278
OVERTIME T_20	286
STOCKHOLM T_20	290
STONWORK T_20	294
STORY T_20	298
WALK T_20	306

Indice per formato

INDEX PER SIZE

Pasta bianca

Wall tiles

50x120

COLOVERS	82
YOUR MATCH	236
YOUR MATCH PALETTE N. 2	240

30,5x91,5

ART	54
H.24	124
MET-ALL	142
OVERTIME	160
PURITY OF MARBLE	170

25x75

COLOVERS	82
MEDLEY	140

Gres porcellanato

Porcelain stoneware

120x120

ART	48
ASTRUM	58
COLOVERS	74
EPIKA	94
H.24	120
OVERTIME	154
PURITY OF MARBLE	164
PURITY OF MARBLE BRECCE	176
PURITY OF MARBLE ELITE	182
PURITY OF MARBLE TUSCANY	190
YOUR MATCH	228

19,7x120

EKHO	88
FREEDHOME	106
HUSK	130
NATURAL APPEAL	148
TRAVEL	216

60x120

ASTRUM	58
COAST ROAD	68
COLOVERS	74
EPIKA	94
FRENCHMOOD	116
H.24	120
OVERTIME	154
PURITY OF MARBLE	164
PURITY OF MARBLE BRECCE	176
PURITY OF MARBLE ELITE	182
PURITY OF MARBLE TUSCANY	190
STONEWORK	196
YOUR MATCH	228

75x150

ART	48
PURITY OF MARBLE	164
PURITY OF MARBLE BRECCE	176
PURITY OF MARBLE ELITE	182
PURITY OF MARBLE TUSCANY	190

80x80

COLOVERS	74
COAST ROAD	68
YOUR MATCH	228

75x75

ART	48
PURITY OF MARBLE	164
PURITY OF MARBLE BRECCE	176
PURITY OF MARBLE ELITE	182
PURITY OF MARBLE TUSCANY	190
STORY	210

60x60

ADIGE	42
ART	48
ASTRUM	58
COAST ROAD	68
COLOVERS	74
EPIKA	94
FRENCHMOOD	116
H.24	120
OVERTIME	154
PURITY OF MARBLE	176
PURITY OF MARBLE TUSCANY	190
STONEWORK	196
STOORM	204
STORY	210
YOUR MATCH	228

45x90

STORY	210
-------------	-----

30x60

ADIGE	42
ART	48
ASTRUM	58
COAST ROAD	68
COLOVERS	74
EPIKA	94
FRENCHMOOD	116
H.24	120
OVERTIME	154
PURITY OF MARBLE	164
PURITY OF MARBLE TUSCANY	190
STONEWORK	196
STOORM	204
STORY	210
YOUR MATCH	228

7,5x60

FREEDHOME	106
HUSK	130
NATURAL APPEAL	148

7,5x30

STORY	210
-------------	-----

22,5x45,3

ADIGE	42
FORTH	100
WALK	222

22,5x22,5

ADIGE	42
FORTH	100
WALK	222

Gres porcellanato

Porcelain stoneware

THICKNESS 6 mm

120x278

ASTRUM	58
COLOVERS	74
H.24	120
PURITY OF MARBLE	164
PURITY OF MARBLE BRECCE	176
PURITY OF MARBLE ELITE	182
PURITY OF MARBLE TUSCANY	190

T.20

Gres porcellanato

Porcelain stoneware

THICKNESS 20 mm

120x120

H.24 T_20	282
-----------------	-----

60x120

ADIGE T_20	254
ASTRUM T_20	262
OVERTIME T_20	286
STONEWORK T_20	294

30x120

EKHO T_20	266
FREEDHOME T_20	278
TRAVEL T_20	302

80x80

ART T_20	258
STORY T_20	298
YOUR MATCH T_20	310

60x90

FORTH T_20	270
WALK T_20	306

45x90

STORY T_20	298
------------------	-----

60x60

ART T_20	258
ASTRUM T_20	262
FRENCH MOOD T_20	278
H.24 T_20	282
OVERTIME T_20	286
STOCKHOLM T_20	290
STONEWORK T_20	294

Adige



ADIGE

GRES PORCELLANATO | PORCELAIN TILE | GRÈS CÉRAMÉ | FEINSTEINZEUG
EN 14411 Allegato G . Piastrelle di ceramica pressate a secco con basso assorbimento d'acqua (E ≤ 0,5%) | Gruppo B la



60x60 RT
R11 A+B+C
± 9 mm



30x60 RT
R11 A+B+C
± 9 mm



22,5x45,3
R11 A+B+C
± 9 mm



22,5x22,5
R11 A+B+C
± 9 mm

SUPERFICIE STRUTTURATA | STRUCTURED SURFACE FINISH | FINITION STRUCTURÉE | STRUKTURIERTE OBERFLÄCHE



60x120 RT
R11 A+B+C
± 20 mm

L20  Page n. 254

ADIGE

Merano 22,5x22,5 . 9"x9" - 22,5x45,3 . 9"x18"



Merano 30x60 RT . 15"x24"
Merano | Trento coda di Pavone 55,5x103 . 21,8"x40,5"



ADIGE

GRES PORCELLANATO | PORCELAIN TILE | GRÈS CÉRAME | FEINSTEINZEUG

TRENTO



FINITURA STRUTTURATA R11 A+B+C		
PTR6	60x60 RT - 24"x24"	± 9 mm
PTN3	30x60 RT - 12"x24"	± 9 mm
RS4P	22,5x45,3 - 9"x18"	± 9 mm
RS2P	22,5x22,5 - 9"x9"	± 9 mm
FINITURA STRUTTURATA R11 A+B+C * T20		
T12A	60x120 RT - 24"x48"	± 20 mm

BOLZANO



FINITURA STRUTTURATA R11 A+B+C		
PB60	60x60 RT - 24"x24"	± 9 mm
P3B0	30x60 RT - 12"x24"	± 9 mm
GR4P	22,5x45,3 - 9"x18"	± 9 mm
GR2P	22,5x22,5 - 9"x9"	± 9 mm
FINITURA STRUTTURATA R11 A+B+C * T20		
B12A	60x120 RT - 24"x48"	± 20 mm

MERANO

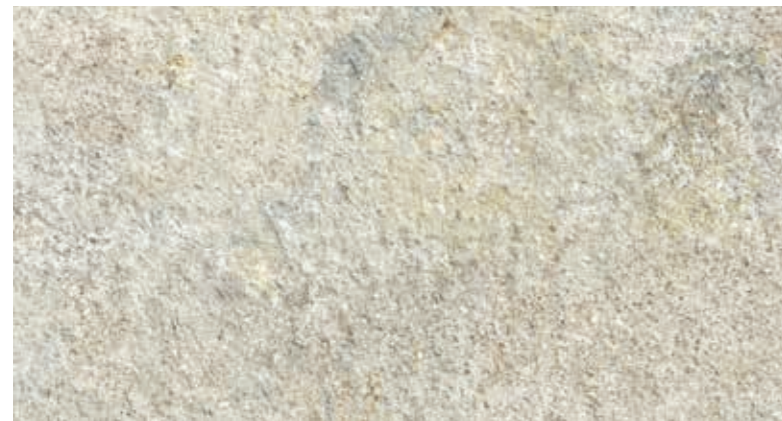

FINITURA STRUTTURATA R11 A+B+C		
PME6	60x60 RT - 24"x24"	± 9 mm
PMR3	30x60 RT - 12"x24"	± 9 mm
PAV4	22,5x45,3 - 9"x18"	± 9 mm
PAV2	22,5x22,5 - 9"x9"	± 9 mm
FINITURA STRUTTURATA R11 A+B+C * T20		
M12A	60x120 RT - 24"x48"	± 20 mm

* Gamma completa Adige T20 a pagina 254 / For the complete range Adige T20 go to page 254

Pezzi speciali

SPECIAL TILES | PIÈCES SPÉCIALES | FORMTEILE

	TRENTO	BOLZANO	MERANO
Gradone c/prof. incollato 33x60 RT	NTG3	BXG3	GM3R
Ang. Gradone c/prof. inc. 33x33 RT	D3TG	D3BG	D3MG
Gradino 30x60 RT	DTEG	DBEG	DMEG
Terminale a Elle TD 15x30x4 h	ALTN	ALBZ	ALTM
* Battiscopa TD 7,2x60	TOBT	BZBT	MBTA

* disponibili solo su ordinazione . available only upon request



CODA DI PAVONE		
MTCP	merano / trento 55,5x103 - 21,8"x40,5"	± 9 mm



CODA DI PAVONE		
BZCP	bolzano 55,5x103 - 21,8"x40,5"	± 9 mm

Imballi

EMBALLAGE | VERPACKUNG | PACKING

	PZ/BOX	MQ/BOX	KG/BOX	BOX/PLT	MQ/PLT	KG/PLT	SPESSORE
60x60 RT	3	1,08	22,00	40	43,20	892	9 mm
30x60 RT	7	1,26	25,00	40	50,40	1012	9 mm
22,5x45,3	12	1,22	23,70	34	41,58	820	9 mm
22,5x22,5	20	1,01	19,40	42	42,52	829	9 mm
coda di pavone	1	0,57	12,00	-	-	-	9 mm
terminale elle TD	8	0,36	10,75	48	17,28	530	-
battiscopa 7,2x60	10	6,00 ml	9,00	70	420 ml	645	-
gradone c/prof. incollato 33x60	4	-	-	-	-	-	-
ang/grad c/prof. incollato 33x33	4	-	-	-	-	-	-
gradino 30x60	7	-	-	-	-	-	-
60x120 RT	1	0,72	32,00	35	25,20	1135	20 mm

AVVERTENZE PER LA POSA - Gres porcellanato

RECOMMENDATIONS FOR INSTALLATION - Porcelain tile

Per la posa del materiale rettificato si prescrive una fuga minima di 2 mm . As for rectified materials, a minimum joint of 2 mm is required . Pour la pose du matériau rectifié, il faut réaliser un joint minimum de 2 mm . Für die Verlegung des geschliffenen Materials ist eine Mindestfuge von 2 mm vorgeschrieben .

Si raccomanda di posare i materiali sfalsati di 20 cm al massimo, mai a metà della loro lunghezza. It is strongly recommended to install the materials in a staggered pattern of a maximum of 20 cm, never at half way its length. Il est conseillé de poser les matériaux en décalé de 20 cm au maximum, jamais à la moitié de leur longueur. Es wird empfohlen, die Materialien um höchstens 20 cm versetzt zu verlegen und nie in der Mitte ihrer Länge.

I formati 22.5x22.5 e 22.5x45.3 sono studiati per consentire pose modulari: a parità di calibro, si consiglia una fuga di 3 mm. 22.5x22.5 and 22.5x45.3 allows modular layouts, leaving a 3mm joint. La modularité est assurée dans le cas d'une installation avec un joint de 3 mm. Die Zusammenstellbarkeit ist bei der Verlegung mit 3 mm breiter Fuge.

GRES PORCELLANATO | PORCELAIN TILE | GRÈS CÉRAME | FEINSTEINZEUG

EN 14411 Allegato G . Piastrelle di ceramica pressate a secco con basso assorbimento d'acqua (E ≤ 0,5%)

Gruppo B Ia

Caratteristiche tecniche	Norma	Superficie
Technical characteristics	Norms	Naturale
Resistenza all'abrasione profonda		
Abrasion resistance	ISO 10545-6	≤ 175 mm³
Resistenza allo scivolamento		
Slip resistance	EN 16165 (previously DIN 51130)	R11
Resistenza allo scivolamento - Superfici bagnate a piedi scalzi		
Coefficient of friction - Dry surfaces walking on barefoot	EN 16165 (previously DIN 51097)	A+B+C
Resistenza allo scivolamento		
Dynamic coefficient of friction (DCOF)	ANSI A326.3	Conforme According to
Coefficiente di attrito dinamico		
Dynamic friction coefficient	METODO B.C.R.A.	Conforme According to
Grado di variazione cromatica		
Colour shade variation	V1 min - V4 max	V4

Art



PAVIMENTO
Art Cement 75x150 RT - 30"x60"

RIVESTIMENTO
Art Pearl struttura Net 30.5x91.5RT - 12"x36"

ART / FLOOR

GRES PORCELLANATO | PORCELAIN TILE | GRÈS CÉRAME | FEINSTEINZEUG
EN 14411 Allegato G . Piastrelle di ceramica pressate a secco con basso assorbimento d'acqua (E ≤ 0,5%) | Gruppo B la

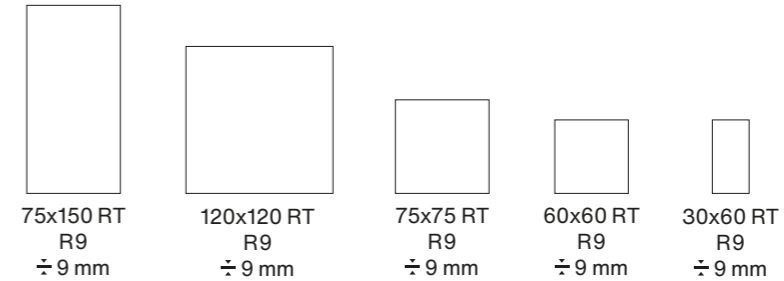

SUPERFICIE NATURALE | NATURAL SURFACE FINISH | SURFACE NATURELLE | NATÜRLICHE OBERFLÄCHE

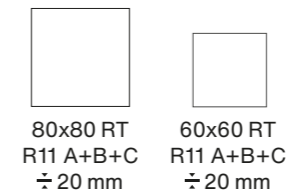

L20 Page n. 258

ART / WALL

RIVESTIMENTO IN PASTA BIANCA | WHITE BODY WALL TILES | REVÊTEMENTS EN PÂTE BLANCHE | WEISBSCHERBIGER WANDFLIESEN
EN 14411 Allegato L . Piastrelle di ceramica pressate a secco (E >10%) | Gruppo BIII

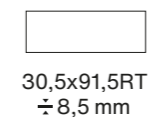
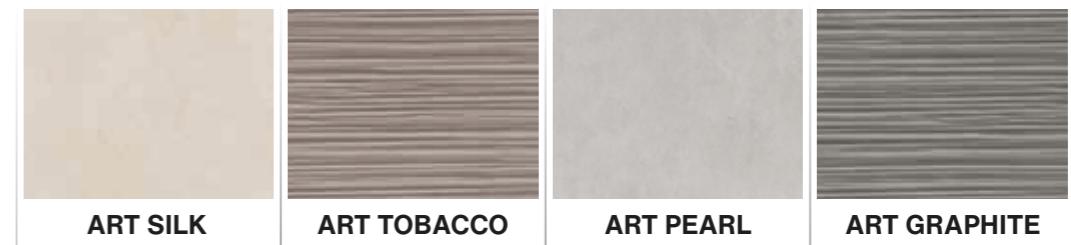

SUPERFICIE SATINATA | SATIN SURFACE FINISH | SURFACE SATINÉE | SATINIERTER OBERFLÄCHE

ART

Art Clay 75x150 RT 30"x60"



RIVESTIMENTO
Art Cement Dec. Melt 75x150RT . 30"x60"
Art Graphite Strutt.Sign 30.5x91.5RT . 12"x36"

PAVIMENTO
Art Graphite 75x150RT . 30"x60"



ART/ FLOOR

GRES PORCELLANATO | PORCELAIN TILE | GRÈS CÉRAMÉ | FEINSTEINZEUG

ART CEMENT



FINITURA NATURALE R9		
R50E	75x150 RT - 30"x60"	± 9 mm
RCKM	75x150 RT dec. melt - 30"x60"	± 9 mm
A12C	120x120 RT - 48"x48"	± 9 mm
CE75	75x75 RT - 30"x30"	± 9 mm
CE60	60x60 RT - 24"x24"	± 9 mm
CM3A	30x60 RT - 12"x24"	± 9 mm
FINITURA STRUTTURATA R11 A+B+C * T20		
CMA8	80x80 RT - 32"x32" T20	± 20 mm
A2CE	60x60 RT - 24"x24" T20	± 20 mm
MOSAICI		
MEKG	mos. esag. dec. grey 34,5x29,8 RT - 12,6"x11,7"	± 9 mm
TC3M	art cement mosaico 30x30 RT - 12"x12"	± 9 mm



Mosaico Esagona



Mosaico

FORMATO TESSERA
MOSAIC SIZE
4,8x4,8 - 2"x2"

ART CEMENT DEC. MELT



ART CLAY



FINITURA NATURALE R9		
R50C	75x150 RT - 30"x60"	± 9 mm
RYKM	75x150 RT dec. melt - 30"x60"	± 9 mm
A12Y	120x120 RT - 48"x48"	± 9 mm
CL75	75x75 RT - 30"x30"	± 9 mm
CY60	60x60 RT - 24"x24"	± 9 mm
CL3A	30x60 RT - 12"x24"	± 9 mm
MOSAICI		
MEKS	mos. esag. dec. sand 34,5x29,8 RT - 12,6"x11,7"	± 9 mm
TCMT	art clay mosaico 30x30 RT - 12"x12"	± 9 mm



Mosaico Esagona



Mosaico

FORMATO TESSERA
MOSAIC SIZE
4,8x4,8 - 2"x2"

ART CLAY DEC. MELT



ART GRAPHITE



FINITURA NATURALE R9		
R50G	75x150 RT - 30"x60"	± 9 mm
A12G	120x120 RT - 48"x48"	± 9 mm
GR75	75x75 RT - 30"x30"	± 9 mm
GR60	60x60 RT - 24"x24"	± 9 mm
GR3A	30x60 RT - 12"x24"	± 9 mm
FINITURA STRUTTURATA R11 A+B+C * T20		
AGH8	80x80 RT - 32"x32" T20	± 20 mm
AGR2	60x60 RT - 24"x24" T20	± 20 mm
MOSAICI		
MEKG	mos. esag. dec. grey 34,5x29,8 RT - 12,6"x11,7"	± 9 mm
TGM3	art graphite mosaico 30x30 RT - 12"x12"	± 9 mm



Mosaico Esagona



Mosaico

FORMATO TESSERA
MOSAIC SIZE
4,8x4,8 - 2"x2"

ART TOBACCO



FINITURA NATURALE R9		
R50T	75x150 RT - 30"x60"	± 9 mm
T075	75x75 RT - 30"x30"	± 9 mm
T060	60x60 RT - 24"x24"	± 9 mm
T03A	30x60 RT - 12"x24"	± 9 mm
MOSAICI		
MEKS	mos. esag. dec. sand 34,5x29,8 RT - 12,6"x11,7"	± 9 mm
TTM3	art tobacco mosaico 30x30 RT - 12"x12"	± 9 mm



Mosaico Esagona



Mosaico

FORMATO TESSERA
MOSAIC SIZE
4,8x4,8 - 2"x2"

ART / WALL



RIVESTIMENTO
 Art Pearl strutt.sign 30.5x91.5 RT - 12"x36"
 Art Pearl 30.5x91.5 RT - 12"x36"
 Art Pearl/Graphite Dec.shade 30.5x91.5 RT - 12"x36"
 Art Graphite Gradone c/prof.inc. 33x150- 13"x60"

PAVIMENTO
 Art Graphite mosaico 30x30 RT
 Art Cement 75x75 RT - 30"x30"

ART / WALL

RIVESTIMENTO IN PASTA BIANCA | WHITE BODY WALL TILES | REVÊTEMENTS EN PÂTE BLANCHE | WEISBSCHERBIGER WANDFLIESEN

ART SILK



AS91 - 30,5x91,5 RT - 12"x36" - ÷ 8,5 mm

ART TOBACCO . STRUTTURA SIGN

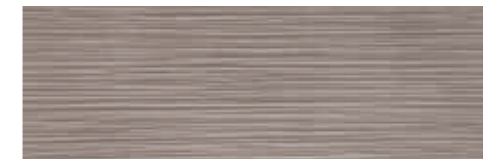

AT9S - 30,5x91,5 RT - 12"x36" - ÷ 8,5 mm MQ

ART PEARL



APE9 - 30,5x91,5 RT - 12"x36" - ÷ 8,5 mm

ART GRAPHITE . STRUTTURA SIGN



AG9S - 30,5x91,5 RT - 12"x36" - ÷ 8,5 mm MQ

ART SILK . STRUTTURA SIGN



AST9 - 30,5x91,5 RT - 12"x36" - ÷ 8,5 mm MQ

ART PEARL . STRUTTURA SIGN



APS9 - 30,5x91,5 RT - 12"x36" - ÷ 8,5 mm MQ

ART SILK . STRUTTURA NET

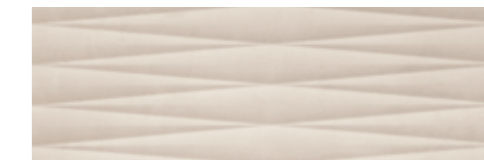

AG9N - 30,5x91,5 RT - 12"x36" - ÷ 8,5 mm MQ

ART SILK/TOBACCO . CAMP. SHADE



AKCS - 30,5x91,5 RT - 12"x36" - ÷ 8,5 mm

ART PEARL . STRUTTURA NET



APSN - 30,5x91,5 RT - 12"x36" - ÷ 8,5 mm MQ

ART PEARL/GRAPHITE . CAMP. SHADE



APSH - 30,5x91,5 RT - 12"x36" - ÷ 8,5 mm

PMAR profilo metallo argento 0,5x100 RT - 0,2"x40"

PMRA profilo metallo rame 0,5x100 RT - 0,2"x40"

Profili in metallo abbinabili a pag. 251
 Metal profiles page 251

PMOR profilo metallo oro 0,5x100 RT - 0,2"x40"

PAVIMENTI COORDINABILI IN GRES PORCELLANATO | COORDINATE FLOORS TILES PORCELAIN STONEWARE
 SOL COORDONNÉ EN GRÉS CÈRAME | KOODINIERTE BODENFLIESEN FEINSTEINZEUG

	ART SILK	ART TOBACCO	ART PEARL	ART GRAPHITE
ART (pag. 48)				
	ART CLAY	ART TOBACCO	ART CEMENT	ART GRAPHITE
FREEDHOME (pag. 106)				
	SAND	ÉCRU	AMBER	TOBACCO
NATURAL APPEAL (pag. 148)				
	NATURAL ALMOND	NATURAL BLONDE	NATURAL WILD	NATURAL LIGHT

ART

GRES PORCELLANATO | PORCELAIN TILE | GRÈS CÉRAME | FEINSTEINZEUG

Pezzi speciali

SPECIAL TILES | PIÈCES SPÉCIALES | FORMTEILE

Pezzi speciali disponibili su tutti i colori, su ordinazione.

Trim tiles available in all colors to order.

Pièces spéciales disponibles dans toutes les couleurs, sur demande.

Formteile auf Bestellung in allen Farben verfügbar.

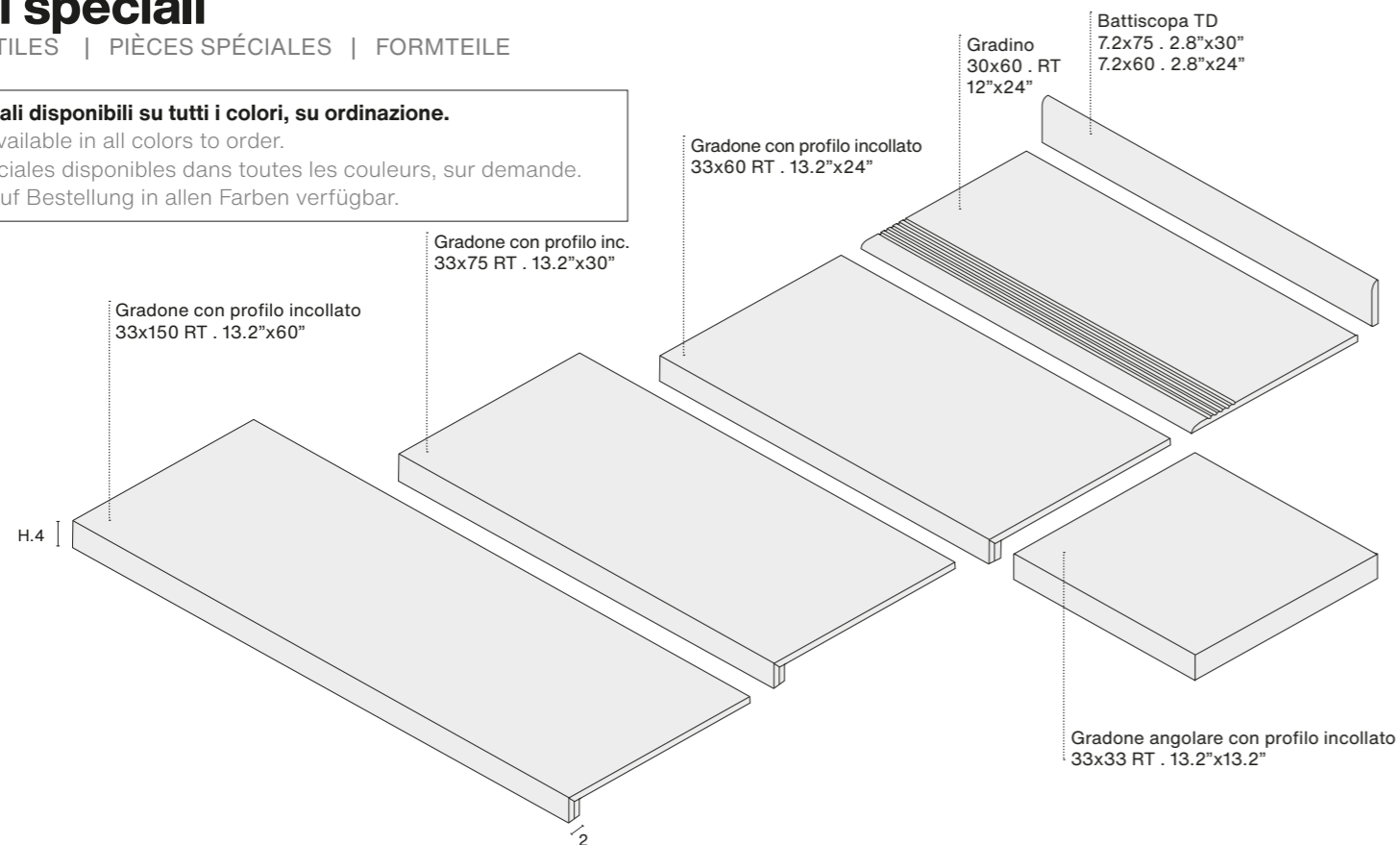

	ART CEMENT	ART GRAPHITE	ART CLAY	ART TOBACCO
Gradone c/prof. incollato 33x150 RT	CGI1	GGI1	CYG1	BGI1
Gradone c/prof. incollato 33x75 RT	GCI7	GGI7	YGI7	BGI7
Gradone c/prof. incollato 33x60 RT	GCI6	GGI6	YGI6	BGI6
Ang. Gradone c/prof. inc. 33x33 RT	C3AG	GA33	YA33	BA33
Gradino 30x60 RT	CMGR	GPGR	CLYG	TBGR
Battiscopa TD 7,2x75	MAB7	GAT6	CAB7	TAB7
Battiscopa TD 7,2x60	MAB6	GAB6	CAB6	TAB6

GRES PORCELLANATO | PORCELAIN TILE | GRÈS CÉRAME | FEINSTEINZEUG

EN 14411 Allegato G . Piastrelle di ceramica pressate a secco con basso assorbimento d'acqua (E ≤ 0,5%)

Gruppo B la

Caratteristiche tecniche Technical characteristics	Norma Norms	Superficie Naturale
Resistenza all'abrasione profonda Abrasion resistance	ISO 10545-6	≤ 175 mm ³
Resistenza allo scivolamento Slip resistance	EN 16165 (previously DIN 51130)	R9
Resistenza allo scivolamento Dynamic coefficient of friction (DCOF)	ANSI A326.3	Conforme According to
Coefficiente di attrito dinamico Dynamic friction coefficient	METODO B.C.R.A.	Conforme According to
	Consultare il sito: Pour plus d'informations consulter:	www.supergres.com/upec
Grado di variazione cromatica Colour shade variation	V1 min - V4 max	V3

Imballi

EMBALLAGE | VERPACKUNG | PACKING

ART / FLOOR

GRES PORCELLANATO | PORCELAIN TILE | GRÈS CÉRAME | FEINSTEINZEUG

	PZ/BOX	MQ/BOX	KG/BOX	BOX/PLT	MQ/PLT	KG/PLT	SPESSORE
120x120 RT	2	2,88	60,00	20	57,60	1212	9 mm
75x150 RT	2	2,25	46,00	18	40,50	840	9 mm
75x75 RT	2	1,125	22,50	42	47,25	957	9 mm
60x60 RT	3	1,08	22,00	40	43,20	892	9 mm
30x60 RT	7	1,26	25,00	40	50,40	1012	9 mm
75x150 RT dec. melt	2	2,25	46,00	18	40,50	840	9 mm
mosaico 30x30RT	10	0,90	16,00	30	27,00	495	9 mm
mosaico esagona dek	6	0,62	11,50	42	25,91	495	9 mm
profilo metallo 0,5x100	3	-	-	-	-	-	8 mm
battiscopa TD 7,2x60	10	6,00 ml	9,00	70	420 ml	645	-
battiscopa TD 7,2x75	10	7,50 ml	10,50	63	472,50 ml	676	-
gradino 30x60	7	-	-	-	-	-	-
gradone c/prof.incollato 33x150	2	-	-	-	-	-	-
gradone c/prof.incollato 33x75	2	-	-	-	-	-	-
gradone c/prof.incollato 33x60	4	-	-	-	-	-	-
ang/grad c/prof.inc. 33x33	4	-	-	-	-	-	-

ART / WALL

RIVESTIMENTO IN PASTA BIANCA | WHITE BODY WALL TILES | REVÊTEMENTS EN PÂTE BLANCHE | WEISßSCHERBIGER WANDFLIESEN

	PZ/BOX	MQ/BOX	KG/BOX	BOX/PLT	MQ/PLT	KG/PLT	SPESSORE
30,5x91,5RT	5	1,395	21,00	42	58,59	894	8,5 mm
30,5x91,5RT struttura sign	4	1,116	20,50	42	46,87	873	8,5 mm*
30,5x91,5RT struttura net	4	1,116	19,50	42	46,87	831	8,5 mm*
30,5x91,5RT campitura	2	-	-	-	-	-	-
34,5x29,8 mosaico esagona dek	6	0,62	11,50	42	26,04	495	9 mm
profilo metallo 0,5x100	3	-	-	-	-	-	8 mm

* Spessore riferito al fondo liscio equivalente . Thickness refers to the equivalent smooth background
Épaisseur se rapportant au carreau lisse équivalent . Die Stärke bezieht sich auf die entsprechende glatte Grundfliese

AVVERTENZE PER LA POSA - Gres porcellanato

RECOMMENDATIONS FOR INSTALLATION - Porcelain tile

Per la posa del materiale rettificato si prescrive una fuga minima di 2 mm.

As for rectified materials, a minimum joint of 2 mm is required.

Pour la pose du matériau rectifié, il faut réaliser un joint minimum de 2 mm.

Für die Verlegung des geschliffenen Materials ist eine Mindestfuge von 2 mm vorgeschrieben.

Si raccomanda di posare i materiali sfalsati di 20 cm al massimo, mai a metà della loro lunghezza

It is strongly recommended to install the materials in a staggered pattern of a maximum of 20 cm, never at half way its length.

Il est conseillé de poser les matériaux en décalé de 20 cm au maximum, jamais à la moitié de leur longueur.

Es wird empfohlen, die Materialien um höchstens 20 cm versetzt zu verlegen und nie in der Mitte ihrer Länge.

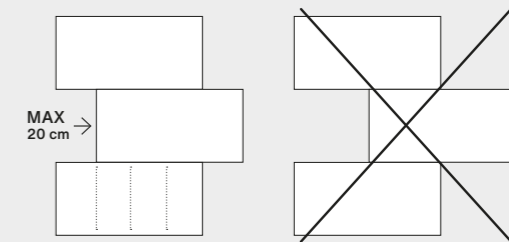

Per maggiori dettagli e aggiornamenti sulle certificazioni, consultare il nostro sito www.supergres.com
For further details and updated information on certifications, please visit our website www.supergres.com
Pour obtenir plus d'informations et de mises à jour sur les certifications, veuillez consulter notre site www.supergres.com
Für weitere Details und Aktualisierungen der Zertifizierungen besuchen Sie bitte unsere Internetseite www.supergres.com

Astrum



White Cross Cut 120x120 RT . 48"x48"
White Cross Cut grip 120x120 RT . 48"x48"

ASTRUM

GRES PORCELLANATO | PORCELAIN TILE | GRÈS CÉRAMÉ | FEINSTEINZEUG
EN 14411 Allegato G . Piastrelle di ceramica pressate a secco con basso assorbimento d'acqua (E ≤ 0,5%) | Gruppo B la

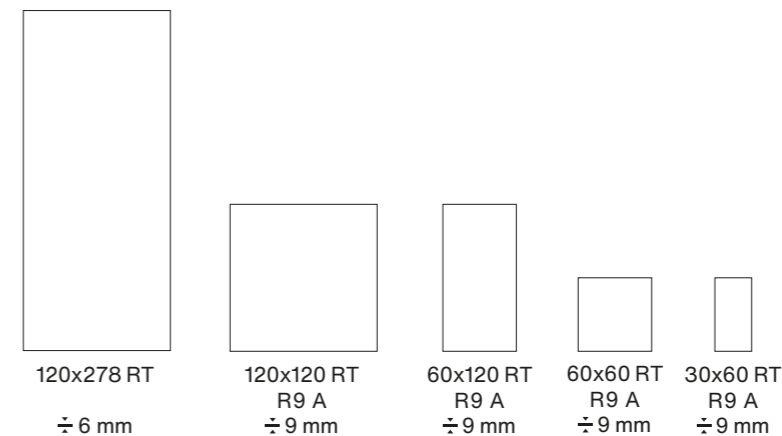

SUPERFICIE NATURALE | NATURAL SURFACE FINISH | SURFACE NATURELLE | NATÜRLICHE OBERFLÄCHE

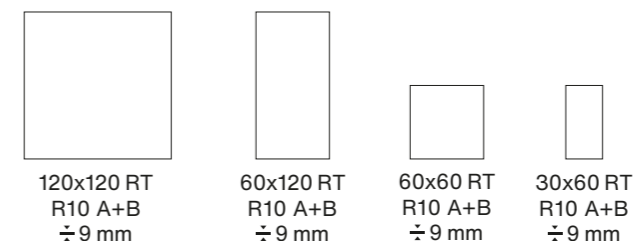

SUPERFICIE ANTI-SLIP SOFT TOUCH - CROSS CUT | ANTI-SLIP SOFT TOUCH SURFACE - CROSS CUT
ANTI-SLIP SOFT TOUCH SURFACE - CROSS CUT | ANTI-SLIP SOFT TOUCH OBERFLÄCHE - CROSS CUT

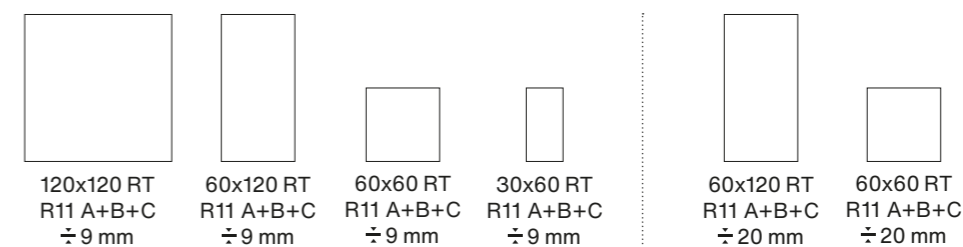

SUPERFICIE GRIP | SURFACE GRIP | SURFACE GRIP | OBERFLÄCHE GRIP

L20 Page n. 262

ASTRUM



White Vein Cut 60x120 RT . 24"x48"



Ivory Cross Cut 120x120 RT . 48"x48"



RIVESTIMENTO
Love White 120x278 RT . 48"x109^{1/2}" Serie Colovers
PAVIMENTO
Light Vein Cut 60x120 RT . 24"x48"

ASTRUM

GRES PORCELLANATO | PORCELAIN TILE | GRÈS CÉRAMÉ | FEINSTEINZEUG

WHITE CROSS CUT



FINITURA NATURALE R9 A		
AH12	120x120 RT - 48"x48"	± 9 mm
WHC6	60x120 RT - 24"x48"	± 9 mm
WH6C	60x60 RT - 24"x24"	± 9 mm
WHC3	30x60 RT - 12"x24"	± 9 mm
FINITURA ANTI-SLIP SOFT TOUCH R10 A+B		
ASW1	120x120 RT - 48"x48"	± 9 mm
WHAS	60x120 RT - 24"x48"	± 9 mm
SWA6	60x60 RT - 24"x24"	± 9 mm
TW3S	30x60 RT - 12"x24"	± 9 mm
FINITURA GRIP R11 A+B+C		
WHG1	120x120 RT - 48"x48"	± 9 mm
IWG1	60x120 RT - 24"x48"	± 9 mm
WHG6	60x60 RT - 24"x24"	± 9 mm
WHG3	30x60 RT - 12"x24"	± 9 mm
FINITURA STRUTTURATA R11 A+B+C * T.20		
WHT2	60x120 RT - 24"x48" T20	± 20 mm
WHS6	60x60 RT - 24"x24" T20	± 20 mm
MOSAICI		
WEAM	mosaico 30x30 RT - 12"x12"	± 9 mm
SHMG	muretto gem 30,5x53,8 - 12"x21"	± 9 mm



Muretto gem



Mosaico

FORMATO TESSERA
MOSAIC SIZE
4,8x4,8 - 2"x2"

IVORY CROSS CUT



120x278 RT FINITURA NATURALE		
WAC8	120x278 RT - 48"x109 1/2"	± 6 mm
FINITURA NATURALE R9 A		
UB12	120x120 RT - 48"x48"	± 9 mm
IT12	60x120 RT - 24"x48"	± 9 mm
AI60	60x60 RT - 24"x24"	± 9 mm
AIC3	30x60 RT - 12"x24"	± 9 mm
FINITURA ANTI-SLIP SOFT TOUCH R10 A+B		
AS11	120x120 RT - 48"x48"	± 9 mm
ASY6	60x120 RT - 24"x48"	± 9 mm
AIA6	60x60 RT - 24"x24"	± 9 mm
AIS3	30x60 RT - 12"x24"	± 9 mm
FINITURA GRIP R11 A+B+C		
UI12	120x120 RT - 48"x48"	± 9 mm
ITG1	60x120 RT - 24"x48"	± 9 mm
AIG6	60x60 RT - 24"x24"	± 9 mm
IVG3	30x60 RT - 12"x24"	± 9 mm
FINITURA STRUTTURATA R11 A+B+C * T.20		
AIV2	60x120 RT - 24"x48" T20	± 20 mm
BIV6	60x60 RT - 24"x24" T20	± 20 mm
MOSAICI		
AIVM	mosaico 30x30 RT - 12"x12"	± 9 mm
AIGM	muretto gem 30,5x53,8 - 12"x21"	± 9 mm



Muretto gem



Mosaico

FORMATO TESSERA
MOSAIC SIZE
4,8x4,8 - 2"x2"

BEIGE CROSS CUT



FINITURA NATURALE R9 A		
UG12	120x120 RT - 48"x48"	± 9 mm
ET12	60x120 RT - 24"x48"	± 9 mm
TB60	60x60 RT - 24"x24"	± 9 mm
ABG3	30x60 RT - 12"x24"	± 9 mm
FINITURA ANTI-SLIP SOFT TOUCH CROSS R10 A+B		
1ASB	120x120 RT - 48"x48"	± 9 mm
TB6S	60x120 RT - 24"x48"	± 9 mm
BG6A	60x60 RT - 24"x24"	± 9 mm
BAS3	30x60 RT - 12"x24"	± 9 mm
FINITURA GRIP R11 A+B+C		
BU12	120x120 RT - 48"x48"	± 9 mm
ETG1	60x120 RT - 24"x48"	± 9 mm
BEG6	60x60 RT - 24"x24"	± 9 mm
BGG3	30x60 RT - 12"x24"	± 9 mm
FINITURA STRUTTURATA R11 A+B+C * T.20		
ABG2	60x120 RT - 24"x48" T20	± 20 mm
BAT6	60x60 RT - 24"x24" T20	± 20 mm
MOSAICI		
BEAM	mosaico 30x30 RT - 12"x12"	± 9 mm
BEMG	muretto gem 30,5x53,8 - 12"x21"	± 9 mm



Muretto gem



Mosaico

FORMATO TESSERA
MOSAIC SIZE
4,8x4,8 - 2"x2"

* Gamma completa Astrum T20 a pagina 262 / For the complete range Astrum T20 go to page 262

ASTRUM

Sand Vein Cut 120x278 RT . 48"x109 1/2"
 Sand Vein Cut grip 60x120 RT . 24"x48"
 Sand Vein Cut muretto arch 28x56 . 11"x22"



ASTRUM

GRES PORCELLANATO | PORCELAIN TILE | GRÈS CÉRAME | FEINSTEINZEUG

WHITE VEIN CUT

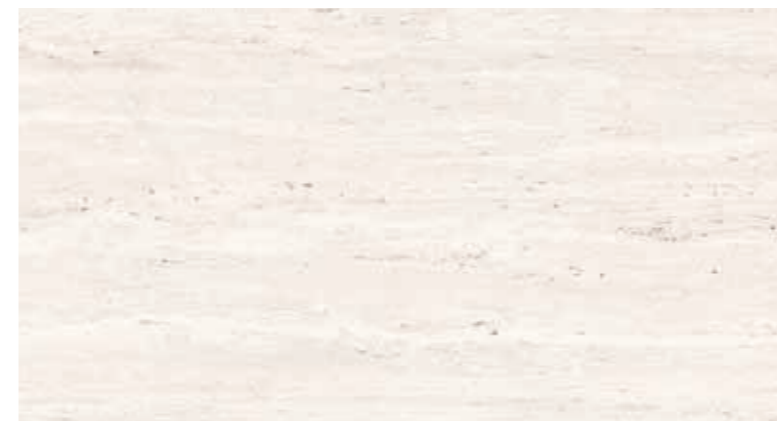

120x278 RT FINITURA NATURALE		
WAV8	120x278 RT - 48"x109 1/2"	± 6 mm
FINITURA NATURALE R9 A		
WHA1	60x120 RT - 24"x48"	± 9 mm
WHV6	60x60 RT - 24"x24"	± 9 mm
SWV3	30x60 RT - 12"x24"	± 9 mm
FINITURA GRIP R11 A+B+C		
IWV1	60x120 RT - 24"x48"	± 9 mm
WHVG	60x60 RT - 24"x24"	± 9 mm
WHV3	30x60 RT - 12"x24"	± 9 mm
MOSAICI		
WHMS	mosaico 30x30 RT - 12"x12"	± 9 mm
WHHA	muretto arch 28x56 - 11"x22"	± 9 mm



Muretto arch



Mosaico

FORMATO TESSERA
 MOSAIC SIZE
 4,8x4,8 - 2"x2"

LIGHT VEIN CUT



FINITURA NATURALE R9 A		
IS12	60x120 RT - 24"x48"	± 9 mm
ALV6	60x60 RT - 24"x24"	± 9 mm
ALH3	30x60 RT - 12"x24"	± 9 mm
FINITURA GRIP R11 A+B+C		
LGV1	60x120 RT - 24"x48"	± 9 mm
ALH6	60x60 RT - 24"x24"	± 9 mm
LHG3	30x60 RT - 12"x24"	± 9 mm
MOSAICI		
LIHM	mosaico 30x30 RT - 12"x12"	± 9 mm
ALUH	muretto arch 28x56 - 11"x22"	± 9 mm



Muretto arch



Mosaico

FORMATO TESSERA
 MOSAIC SIZE
 4,8x4,8 - 2"x2"

SAND VEIN CUT



120x278 RT FINITURA NATURALE		
ALV8	120x278 RT - 48"x109 1/2"	± 6 mm
FINITURA NATURALE R9 A		
ST12	60x120 RT - 24"x48"	± 9 mm
6ASN	60x60 RT - 24"x24"	± 9 mm
SST3	30x60 RT - 12"x24"	± 9 mm
FINITURA GRIP R11 A+B+C		
LSV1	60x120 RT - 24"x48"	± 9 mm
6ASD	60x60 RT - 24"x24"	± 9 mm
GTS3	30x60 RT - 12"x24"	± 9 mm
MOSAICI		
SNDM	mosaico 30x30 RT - 12"x12"	± 9 mm
SNMA	muretto arch 28x56 - 11"x22"	± 9 mm



Muretto arch



Mosaico

FORMATO TESSERA
 MOSAIC SIZE
 4,8x4,8 - 2"x2"

ASTRUM

GRES PORCELLANATO | PORCELAIN TILE | GRÈS CÉRAMÉ | FEINSTEINZEUG

Pezzi speciali

SPECIAL TILES | PIÈCES SPÉCIALES | FORMTEILE

Pezzi speciali disponibili su tutti i colori, su ordinazione.

Trim tiles available in all colors to order.

Pièces spéciales disponibles dans toutes les couleurs, sur demande.

Formteile auf Bestellung in allen Farben verfügbar.

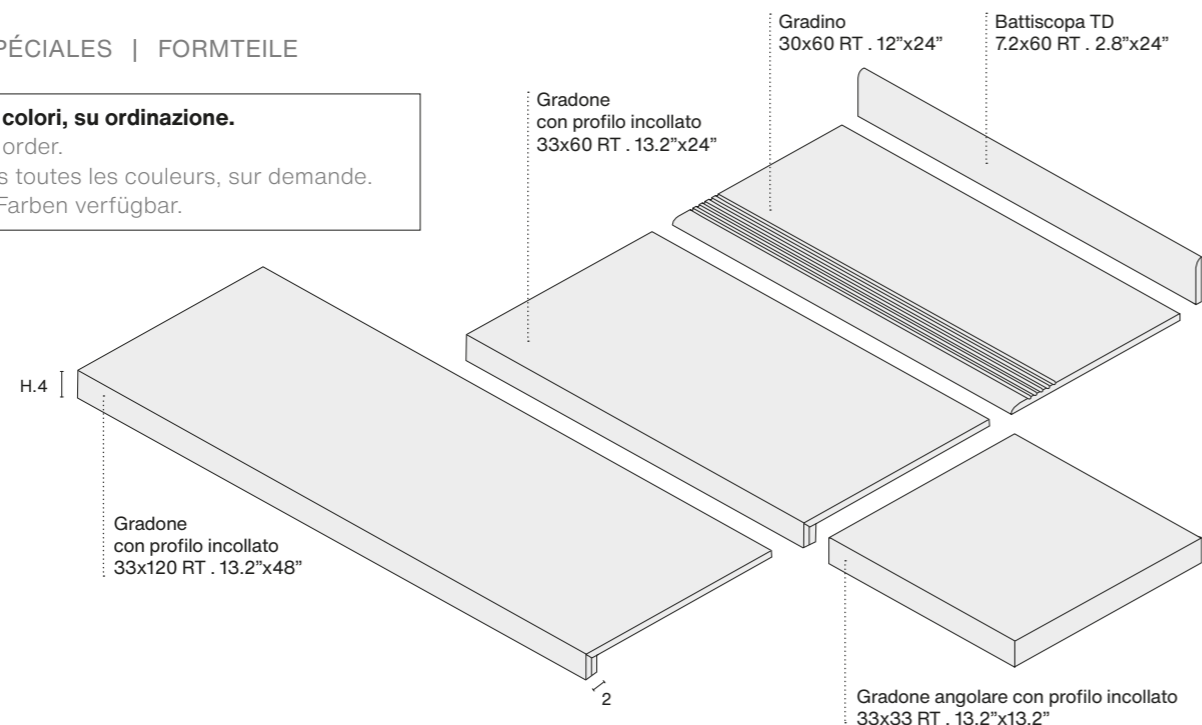

	WHITE CROSS CUT	IVORY CROSS CUT	BEIGE CROSS CUT	WHITE VEIN CUT	LIGHT VEIN CUT	SAND VEIN CUT
Gradone c/prof. incollato 33x120 RT	WGA1	AIG1	BGA1	WHGR	LHG1	SAG1
Gradone c/prof. incollato 33x60 RT	WG6H	AI6G	AG6B	WVG6	AHGR	SN6G
Ang. Gradone c/prof. inc. 33x33 RT	W33A	AIVA	B33A	H33W	LAIG	AG33
Gradino 30x60 RT	W3GH	GRAI	BGR3	3WHG	LHGD	SNDG
Battiscopa TD 7,2x60	WHBT	AVBT	BABT	VWBT	ALTB	SANB

GRES PORCELLANATO | PORCELAIN TILE | GRÈS CÉRAMÉ | FEINSTEINZEUG

EN 14411 Allegato G . Piastrelle di ceramica pressate a secco con basso assorbimento d'acqua (E ≤ 0,5%)

Gruppo B Ia

Caratteristiche tecniche Technical characteristics	Norma Norms	Superficie Naturale	Superficie anti-slip Soft touch	Superficie Grip
Resistenza all'abrasione profonda Abrasion resistance	ISO 10545-6	≤ 175 mm ³	≤ 175 mm ³	≤ 175 mm ³
Resistenza allo scivolamento Slip resistance	EN 16165 (previously DIN 51130)	R9	R10	R11
Resistenza allo scivolamento - Superfici bagnate a piedi scalzi Coefficient of friction - Dry surfaces walking on barefoot	EN 16165 (previously DIN 51097)	A	A+B	A+B+C
Resistenza allo scivolamento Dynamic coefficient of friction (DCOF)	ANSI A326.3	Conforme According to	Conforme According to	Conforme According to
Coefficiente di attrito dinamico Dynamic friction coefficient	METODO B.C.R.A.	Conforme According to	Conforme According to	Conforme According to

UPEC Consultare il sito: www.supergres.com/upec
Pour plus d'informations consulter:

Grado di variazione cromatica
Colour shade variation V1 min - V4 max V3

Imballi

EMBALLAGE | VERPACKUNG | PACKING

ASTRUM

GRES PORCELLANATO | PORCELAIN TILE | GRÈS CÉRAMÉ | FEINSTEINZEUG

FORMATO	PZ	MQ/PZ	KG/PZ	PZ/CASSA*	MQ/CASSA*	KG/CASSA*	SPESSORE
120x278 RT	1	3,34	49,50	18	60,05	979	6 mm
120x278 RT	1	3,34	49,50	5	16,68	301	6 mm

* 120x278 fornito in casse di dimensioni 291,6x144,5x33,8 (PxLxH) cm - Peso kg 88 / o in casse per max 5 pz dim.291.6x144.5x24h - peso kg 52.5
* 120x278 supplied in crates. Dimensions crate cm 291,6x144,5x33,8h cm - Weight kg 88 / crates 5 pcs (charge max). Dim.291.6x144.5x24h - Weight kg 52.5

	PZ	MQ/PZ	KG/PZ	PZ/CAV. **	MQ/CAV. **	KG/CAV. **	SPESSORE
120x278 RT	1	3,34	49,50	18	60,05	1051	6 mm
120x278 RT	1	3,34	49,50	42	140,11	2259	6 mm

** 120x278 fornito su cavalletti (18 pz o 42 pz - carico max) di dimensioni 290x75x156 (PxLxH) cm - Peso kg 160
** 120x278 supplied in stand containing (18 pcs or 42 pcs - charge max). Dimensions cm 290x75x156h cm - Weight kg 160

	PZ/BOX	MQ/BOX	KG/BOX	BOX/PLT	MQ/PLT	KG/PLT	SPESSORE
120x120 RT / grip / anti-slip soft touch	2	2,88	60,00	20	57,60	1212	9 mm
60x120 RT / grip / anti-slip soft touch	2	1,44	30,00	35	50,40	1062	9 mm
60x60 RT / grip / anti-slip soft touch	3	1,08	22,00	40	43,20	892	9 mm
30x60 RT / grip / anti-slip soft touch	7	1,26	25,00	40	50,40	1012	9 mm
mosaico 30x30 RT	10	0,90	16,00	30	27,00	495	9 mm
muretto arch 28x56	4	0,627	13,00	-	-	-	9 mm
muretto gem 30,5x53,8	4	0,656	13,50	-	-	-	9 mm
battiscopa 7,2x60	10	6,00 ml	9,00	70	420 ml	645	-
gradone c/p inc. 33x120 RT	2	-	-	-	-	-	-
gradone c/p inc. 33x60 RT	4	-	-	-	-	-	-
angolare gradone c/p inc. 33x33 RT	4	-	-	-	-	-	-
gradino 30x60 RT	7	-	-	-	-	-	-

AVVERTENZE PER LA POSA - Gres porcellanato

RECOMMENDATIONS FOR INSTALLATION - Porcelain tile

Per la posa del materiale rettificato si prescrive una fuga minima di 2 mm.

As for rectified materials, a minimum joint of 2 mm is required.

Pour la pose du matériau rectifié, il faut réaliser un joint minimum de 2 mm.

Für die Verlegung des geschliffenen Materials ist eine Mindestfuge von 2 mm vorgeschrieben.

Avvertenze per la posa lastre 120x278RT a pag. 335.

Raccomandation for installation slabs 120x278 RT on page 335.

Recommandations pour la pose des plaques 120x278 à la page 335.

Hinweise zum Verlegen 120x278 RT auf Seite 335.

Si raccomanda di posare i materiali sfalsati di 20 cm al massimo, mai a metà della loro lunghezza

It is strongly recommended to install the materials in a staggered pattern of a maximum of 20 cm, never at half way its length.

Il est conseillé de poser les matériaux en décalé de 20 cm au maximum, jamais à la moitié de leur longueur.

Es wird empfohlen, die Materialien um höchstens 20 cm versetzt zu verlegen und nie in der Mitte ihrer Länge.

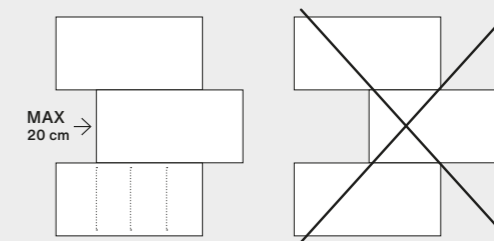

Per maggiori dettagli e aggiornamenti sulle certificazioni, consultare il nostro sito www.supergres.com
For further details and updated information on certifications, please visit our website www.supergres.com
Pour obtenir plus d'informations et de mises à jour sur les certifications, veuillez consulter notre site www.supergres.com
Für weitere Details und Aktualisierungen der Zertifizierungen besuchen Sie bitte unsere Internetseite www.supergres.com

Coast Road



Coast Sand 60x120 RT - 24"x48"

COAST ROAD

GRES PORCELLANATO | PORCELAIN TILE | GRÈS CÉRAMÉ | FEINSTEINZEUG
EN 14411 Allegato G . Piastrelle di ceramica pressate a secco con basso assorbimento d'acqua (E ≤ 0,5%) | Gruppo B la

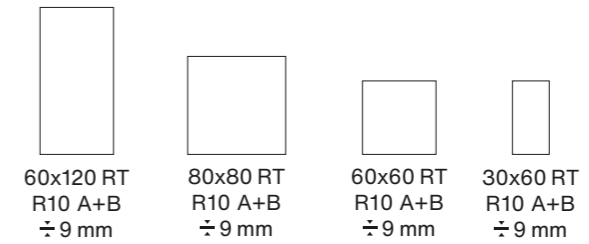
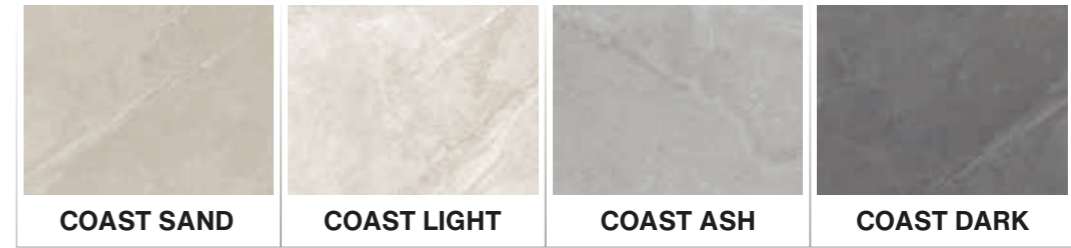

SUPERFICIE ANTI-SLIP SOFT TOUCH | ANTI-SLIP SOFT TOUCH SURFACE
ANTI-SLIP SOFT TOUCH SURFACE | ANTI-SLIP SOFT TOUCH OBERFLÄCHE

COAST ROAD

GRES PORCELLANATO | PORCELAIN TILE | GRÈS CÉRAMÉ | FEINSTEINZEUG

COAST LIGHT



FINITURA ANTI-SLIP SOFT TOUCH R10 A+B		
CSL1	60x120 RT - 24"x48"	± 9 mm
YCL8	80x80 RT - 32"x32"	± 9 mm
60CL	60x60 RT - 24"x24"	± 9 mm
CLI3	30x60 RT - 12"x24"	± 9 mm
MOSAICI		
LGMT	mosaico tangram dek 27x30 - 10,6"x12"	± 9 mm
IMS3	mosaico 30x30 RT - 12"x12"	± 9 mm



Mosaico Tangram Dek



Mosaico

FORMATO TESSERA
MOSAIC SIZE
4,8x4,8 - 2"x2"

COAST ASH



FINITURA ANTI-SLIP SOFT TOUCH R10 A+B		
CSA1	60x120 RT - 24"x48"	± 9 mm
CAH8	80x80 RT - 32"x32"	± 9 mm
60CH	60x60 RT - 24"x24"	± 9 mm
CAH3	30x60 RT - 12"x24"	± 9 mm
MOSAICI		
AHMT	mosaico tangram dek 27x30 - 10,6"x12"	± 9 mm
HMS3	mosaico 30x30 RT - 12"x12"	± 9 mm



Mosaico Tangram Dek



Mosaico

FORMATO TESSERA
MOSAIC SIZE
4,8x4,8 - 2"x2"

COAST SAND



FINITURA ANTI-SLIP SOFT TOUCH R10 A+B		
CSS2	60x120 RT - 24"x48"	± 9 mm
CSN8	80x80 RT - 32"x32"	± 9 mm
60CS	60x60 RT - 24"x24"	± 9 mm
SNC3	30x60 RT - 12"x24"	± 9 mm
MOSAICI		
SNMT	mosaico tangram dek 27x30 - 10,6"x12"	± 9 mm
SMS3	mosaico 30x30 RT - 12"x12"	± 9 mm

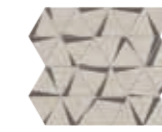

Mosaico Tangram Dek



Mosaico

FORMATO TESSERA
MOSAIC SIZE
4,8x4,8 - 2"x2"

COAST DARK



FINITURA ANTI-SLIP SOFT TOUCH R10 A+B		
CSD1	60x120 RT - 24"x48"	± 9 mm
60CD	60x60 RT - 24"x24"	± 9 mm
CDK3	30x60 RT - 12"x24"	± 9 mm
MOSAICI		
DKMT	mosaico tangram dek 27x30 - 10,6"x12"	± 9 mm
DMS3	mosaico 30x30 RT - 12"x12"	± 9 mm



Mosaico Tangram Dek



Mosaico

FORMATO TESSERA
MOSAIC SIZE
4,8x4,8 - 2"x2"

COAST ROAD

GRES PORCELLANATO | PORCELAIN TILE | GRÈS CÉRAMÉ | FEINSTEINZEUG

Pezzi speciali

SPECIAL TILES | PIÈCES SPÉCIALES | FORMTEILE

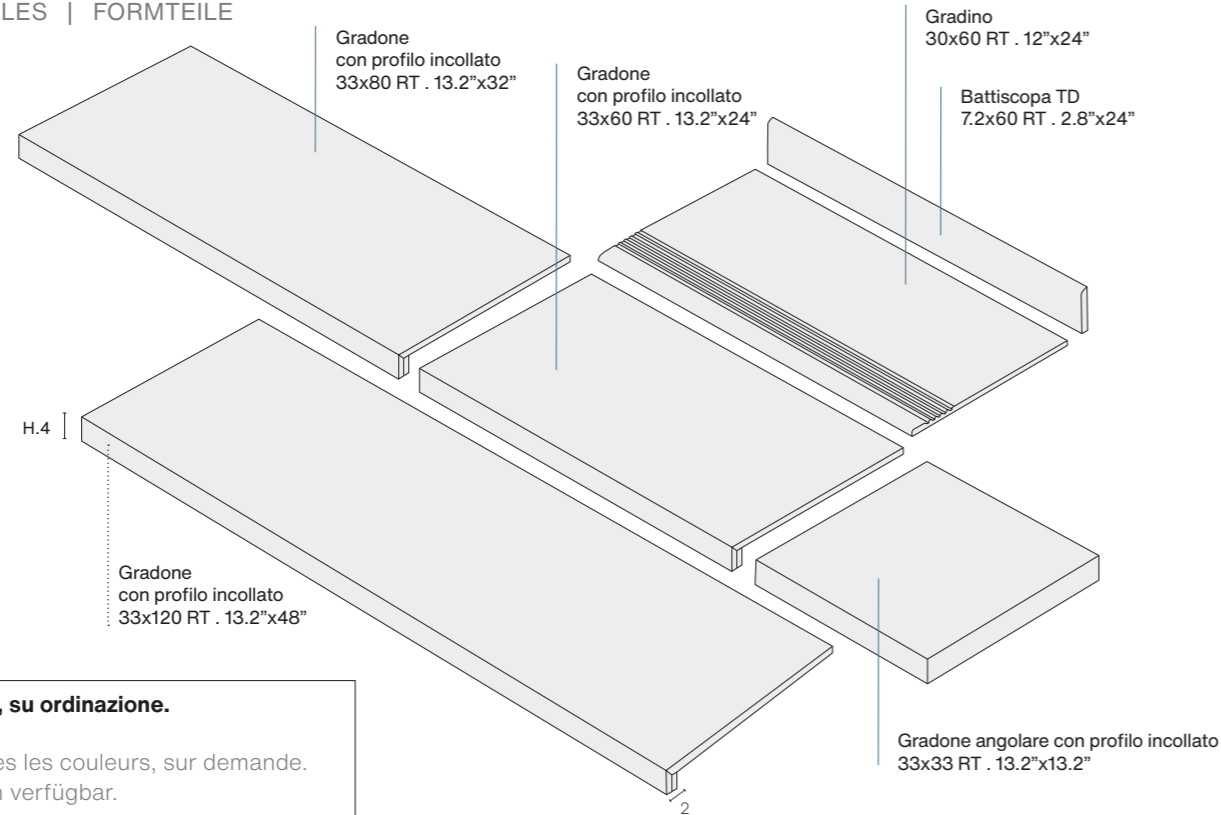

Pezzi speciali disponibili su tutti i colori, su ordinazione.
 Trim tiles available in all colors to order.
 Pièces spéciales disponibles dans toutes les couleurs, sur demande.
 Formteile auf Bestellung in allen Farben verfügbar.



	COAST LIGHT	COAST SAND	COAST ASH	COAST DARK
Gradone c/prof. incollato 33x120 RT	LIG1	CNG1	AHG1	CKG1
Gradone c/prof. incollato 33x80 RT	CLH8	CSDG	CGA8	-
Gradone c/prof. incollato 33x60 RT	LIG6	CDG6	AHG6	CKG6
Ang. Gradone c/prof. inc. 33x33 RT	CLIG	CSGR	CSAG	CDAG
Gradino 30x60 RT	CLHG	CSNG	CAHG	CDKG
Battiscopa TD 7,2x60	LIB7	SNB7	AHB7	DKB7

GRES PORCELLANATO | PORCELAIN TILE | GRÈS CÉRAMÉ | FEINSTEINZEUG

EN 14411 Allegato G . Piastrelle di ceramica pressate a secco con basso assorbimento d'acqua (E ≤ 0,5%)

Gruppo B la

Caratteristiche tecniche Technical characteristics	Norma Norms	Superficie Naturale
Resistenza all'abrasione profonda Abrasion resistance	ISO 10545-6	≤ 175 mm ³
Resistenza allo scivolamento Slip resistance	EN 16165 (previously DIN 51130)	R10
Resistenza allo scivolamento - Superfici bagnate a piedi scalzi Coefficient of friction - Dry surfaces walking on barefoot	EN 16165 (previously DIN 51097)	A+B
Resistenza allo scivolamento Dynamic coefficient of friction (DCOF)	ANSI A326.3	Conforme According to
Coefficiente di attrito dinamico Dynamic friction coefficient	METODO B.C.R.A.	Conforme According to
Grado di variazione cromatica Colour shade variation	V1 min - V4 max	V2

Imballi

EMBALLAGE | VERPACKUNG | PACKING

COAST ROAD

GRES PORCELLANATO | PORCELAIN TILE | GRÈS CÉRAMÉ | FEINSTEINZEUG

	PZ/BOX	MQ/BOX	KG/BOX	BOX/PLT	MQ/PLT	KG/PLT	SPESSORE
60x120 RT	2	1,44	30,00	35	50,40	1062	9 mm
80x80 RT	2	1,28	25,50	48	61,44	1236	9 mm
60x60 RT	3	1,08	22,00	40	43,20	892	9 mm
30x60 RT	7	1,26	25,00	40	50,40	1012	9 mm
mosaico su rete 30x30RT	10	0,90	16,00	30	27,00	495	9 mm
mosaico Tangram Dek	6	0,49	9,00	48	23,33	444	9 mm
battiscopa TD 7,2x60	10	6,00 ml	9,40	70	420 ml	673	-
gradino 30x60	7	-	-	-	-	-	-
gradone c/prof.incollato 33x120 RT	2	-	-	-	-	-	-
gradone c/prof.incollato 33x80 RT	2	-	-	-	-	-	-
gradone c/prof.incollato 33x60 RT	4	-	-	-	-	-	-
ang/grad c/prof.inc. 33x33 RT	4	-	-	-	-	-	-

AVVERTENZE PER LA POSA - Gres porcellanato

RECOMMENDATIONS FOR INSTALLATION - Porcelain tile

Per la posa del materiale rettificato si prescrive una fuga minima di 2 mm.

As for rectified materials, a minimum joint of 2 mm is required.

Pour la pose du matériau rectifié, il faut réaliser un joint minimum de 2 mm.

Für die Verlegung des geschliffenen Materials ist eine Mindestfuge von 2 mm vorgeschrieben.

Si raccomanda di posare i materiali sfalsati di 20 cm al massimo, mai a metà della loro lunghezza

It is strongly recommended to install the materials in a staggered pattern of a maximum of 20 cm, never at half way its length.

Il est conseillé de poser les matériaux en décalé de 20 cm au maximum, jamais à la moitié de leur longueur.

Es wird empfohlen, die Materialien um höchstens 20 cm versetzt zu verlegen und nie in der Mitte ihrer Länge.

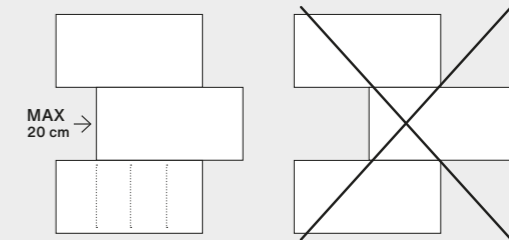

Per maggiori dettagli e aggiornamenti sulle certificazioni, consultare il nostro sito www.supergres.com
 For further details and updated information on certifications, please visit our website www.supergres.com
 Pour obtenir plus d'informations et de mises à jour sur les certifications, veuillez consulter notre site www.supergres.com
 Für weitere Details und Aktualisierungen der Zertifizierungen besuchen Sie bitte unsere Internetseite www.supergres.com

Colovers



PAVIMENTO
Love Sand 80x80 RT . 32"x32"

RIVESTIMENTO
Love Sand 50x120 RT . 20"x48"
Love Brown 50x120 RT . 20"x48"

COLOVERS / FLOOR

GRES PORCELLANATO | PORCELAIN TILE | GRÈS CÉRAME | FEINSTEINZEUG
EN 14411 Allegato G . Piastrelle di ceramica pressate a secco con basso assorbimento d'acqua (E ≤ 0,5%) | Gruppo B Ia

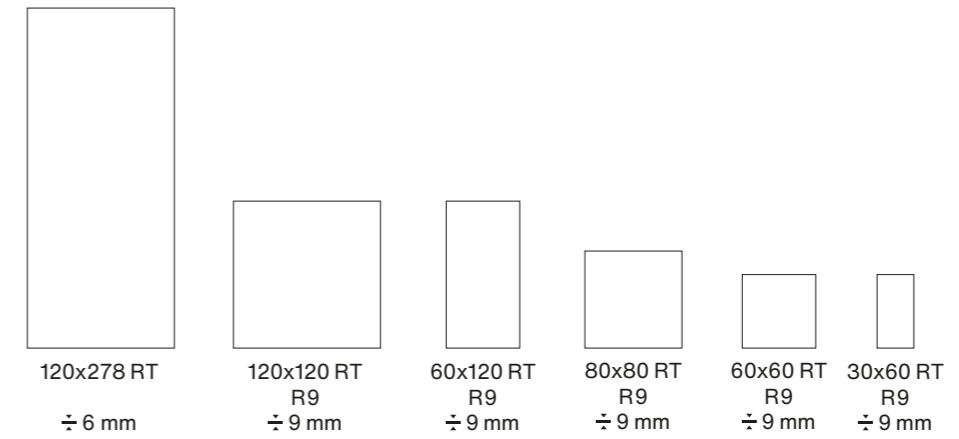

SUPERFICIE NATURALE | NATURAL SURFACE FINISH | SURFACE NATURELLE | NATÜRLICHE OBERFLÄCHE

COLOVERS / WALL

RIVESTIMENTO IN PASTA BIANCA | WHITE BODY WALL TILES | REVÊTEMENTS EN PÂTE BLANCHE | WEISBSCHERBIGER WANDFLIESEN
EN 14411 Allegato L . Piastrelle di ceramica pressate a secco (E >10%) | Gruppo BIII

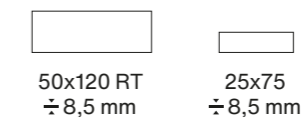

SUPERFICIE SATINATA | SATIN SURFACE FINISH | SURFACE SATINÉE | SATINIERTA OBERFLÄCHE

COLOVERS

RIVESTIMENTO
Love White 120x278 RT . 48"x109 1/2"

PAVIMENTO
Love Black 120x120 RT . 48"x48"



RIVESTIMENTO
Love Campitura Blend Cobalt 120x278 RT . 48"x109 1/2"

PAVIMENTO
Love Cobalt 120x120 RT . 48"x48"



RIVESTIMENTO
Love White 50x120 RT . 20"x48"
Love Cobalt 50x120 RT . 20"x48"
Love Cobalt Nest 50x120 RT . 20"x48"

PAVIMENTO
Purity Statuario Lux 120x120 RT . 48"x48"
Serie Purity of marble

COLOVERS / FLOOR

GRES PORCELLANATO | PORCELAIN TILE | GRÈS CÉRAMÉ | FEINSTEINZEUG

LOVE WHITE



120x278 RT FINITURA NATURALE		
LWH8	120x278 RT - 48"x109 ^{1/2} "	± 6 mm
LBDC	love campitura blend cobalt 120x278 RT - 48"x109 ^{1/2} "	± 6 mm
FINITURA NATURALE R9		
LWH1	120x120 RT - 48"x48"	± 9 mm
LW12	60x120 RT - 24"x48"	± 9 mm
LW60	60x60 RT - 24"x24"	± 9 mm
LW30	30x60 RT - 12"x24"	± 9 mm
MOSAICI		
LSHS	mosaico 30x30 RT - 12"x12"	± 9 mm

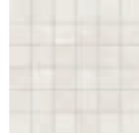

Mosaico

FORMATO TESSERA
MOSAIC SIZE
4,8x4,8 - 2"x2"

*LOVE CAMPITURA BLEND COBALT



MQ

LOVE SAND



120x278 RT FINITURA NATURALE		
LSN8	120x278 RT - 48"x109 ^{1/2} "	± 6 mm
LBDB	love campitura blend bronze 120x278 RT - 48"x109 ^{1/2} "	± 6 mm
FINITURA NATURALE R9		
LSN1	120x120 RT - 48"x48"	± 9 mm
LSA8	80x80 RT - 32"x32"	± 9 mm
LN12	60x120 RT - 24"x48"	± 9 mm
LD60	60x60 RT - 24"x24"	± 9 mm
LS30	30x60 RT - 12"x24"	± 9 mm
MOSAICI		
LSNS	mosaico 30x30 RT - 12"x12"	± 9 mm

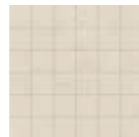

Mosaico

FORMATO TESSERA
MOSAIC SIZE
4,8x4,8 - 2"x2"

*LOVE CAMPITURA BLEND BRONZE



MQ

* Per la pulizia si consiglia l'utilizzo di un panno morbido con acqua e sapone neutro. Evitare l'utilizzo di prodotti acidi o alcalini, ceranti, pagliette di metallo o abrasive.
The use of a common mild detergent is recommended. Avoid using acidic or alkaline products, waxes, steel wool, or abrasives.

LOVE PEARL



120x278 RT FINITURA NATURALE		
LPE8	120x278 RT - 48"x109 ^{1/2} "	± 6 mm
FINITURA NATURALE R9		
LPE1	120x120 RT - 48"x48"	± 9 mm
LPR8	80x80 RT - 32"x32"	± 9 mm
LP12	60x120 RT - 24"x48"	± 9 mm
L60P	60x60 RT - 24"x24"	± 9 mm
LP30	30x60 RT - 12"x24"	± 9 mm
MOSAICI		
LP30	mosaico 30x30 RT - 12"x12"	± 9 mm

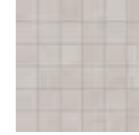

Mosaico

FORMATO TESSERA
MOSAIC SIZE
4,8x4,8 - 2"x2"

LOVE COBALT



FINITURA NATURALE R9		
LCT1	120x120 RT - 48"x48"	± 9 mm
LC12	60x120 RT - 24"x48"	± 9 mm
LA60	60x60 RT - 24"x24"	± 9 mm
LC30	30x60 RT - 12"x24"	± 9 mm
MOSAICI		
LCOS	mosaico 30x30 RT - 12"x12"	± 9 mm



Mosaico

FORMATO TESSERA
MOSAIC SIZE
4,8x4,8 - 2"x2"

COLOVERS / FLOOR

GRES PORCELLANATO | PORCELAIN TILE | GRÈS CÉRAME | FEINSTEINZEUG

LOVE GREY



FINITURA NATURALE R9		
LGR1	120x120 RT - 48"x48"	± 9 mm
LGR8	80x80 RT - 32"x32"	± 9 mm
LY12	60x120 RT - 24"x48"	± 9 mm
LR60	60x60 RT - 24"x24"	± 9 mm
LY30	30x60 RT - 12"x24"	± 9 mm
MOSAICI		
LYMS	mosaico 30x30 RT - 12"x12"	± 9 mm



Mosaico

FORMATO TESSERA
MOSAIC SIZE
4,8x4,8 - 2"x2"

LOVE BLACK

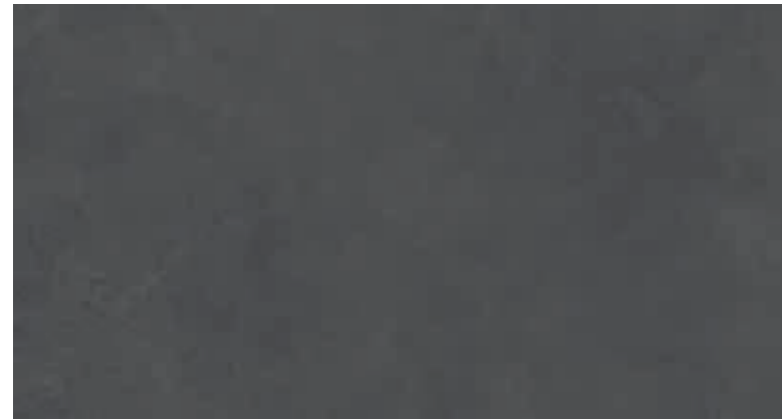

FINITURA NATURALE R9		
LBL1	120x120 RT - 48"x48"	± 9 mm
LB12	60x120 RT - 24"x48"	± 9 mm
LK60	60x60 RT - 24"x24"	± 9 mm
LK30	30x60 RT - 12"x24"	± 9 mm
MOSAICI		
LKMS	mosaico 30x30 RT - 12"x12"	± 9 mm



Mosaico

FORMATO TESSERA
MOSAIC SIZE
4,8x4,8 - 2"x2"

LOVE BRONZE



FINITURA NATURALE R9		
LBR8	80x80 RT - 32"x32"	± 9 mm
LZ60	60x60 RT - 24"x24"	± 9 mm
LZ30	30x60 RT - 12"x24"	± 9 mm
MOSAICI		
LZMS	mosaico 30x30 RT - 12"x12"	± 9 mm



Mosaico

FORMATO TESSERA
MOSAIC SIZE
4,8x4,8 - 2"x2"

LOVE BROWN



FINITURA NATURALE R9		
LBW8	80x80 RT - 48"x48"	± 9 mm
LN60	60x60 RT - 24"x24"	± 9 mm
LB30	30x60 RT - 12"x24"	± 9 mm
MOSAICI		
LWNM	mosaico 30x30 RT - 12"x12"	± 9 mm



Mosaico

FORMATO TESSERA
MOSAIC SIZE
4,8x4,8 - 2"x2"

COLOVERS / WALL



RIVESTIMENTO
 Love Pearl 50x120 RT . 20"x48"
 Love Bronze 50x120 RT . 20"x48"
 Love Campitura Picasso Warm 2/s 50x120 RT . 20"x48"

PAVIMENTO
 Love Pearl 60x120 RT . 24"x48"

COLOVERS / WALL

RIVESTIMENTO IN PASTA BIANCA | WHITE BODY WALL TILES | REVÊTEMENTS EN PÂTE BLANCHE | WEISBSCHERBIGER WANDFLIESEN

LOVE WHITE



LWH5 - 50x120 RT - 20"x48" - ÷ 8,5 mm

LOVE PEARL



LPE5 - 50x120 RT - 20"x48" - ÷ 8,5 mm

LOVE SAND

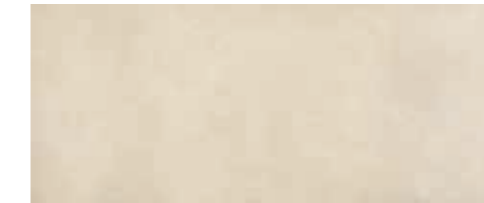

LSN5 - 50x120 RT - 20"x48" - ÷ 8,5 mm

LOVE COBALT



LC05 - 50x120 RT - 20"x48" - ÷ 8,5 mm

LOVE BRONZE



LBN5 - 50x120 RT - 20"x48" - ÷ 8,5 mm

LOVE BROWN



LBR5 - 50x120 RT - 20"x48" - ÷ 8,5 mm

LOVE WHITE . STRUTTURA BRUSH



LWBR - 50x120 RT - 20"x48"



LOVE PEARL . STRUTTURA BRUSH



LPBE - 50x120 RT - 20"x48"



LOVE SAND . STRUTTURA BRUSH



LSSH - 50x120 RT - 20"x48"



LOVE COBALT . NEST



LCNS - 50x120 RT - 20"x48"



LOVE BRONZE . NEST



LZNS - 50x120 RT - 20"x48"



LOVE BROWN . NEST



LWNS - 50x120 RT - 20"x48"



COLOVERS / WALL

RIVESTIMENTO IN PASTA BIANCA | WHITE BODY WALL TILES | REVÊTEMENTS EN PÂTE BLANCHE | WEISBSCHERBIGER WANDFLIESEN

LOVE SAND . CAMPITURA RAMAGE *



LDRM - 50x120 RT - 20"x48" - ± 8,5 mm MQ

LOVE WHITE . CAMPITURA RAMAGE *

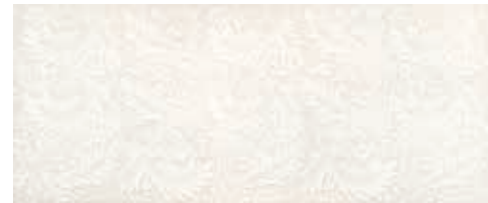

LWRM - 50x120 RT - 20"x48" - ± 8,5 mm MQ

LOVE PEARL . CAMPITURA RAMAGE *



LECR - 50x120 RT - 20"x48" - ± 8,5 mm MQ

LOVE COBALT . CAMPITURA RAMAGE *



LBRM - 50x120 RT - 20"x48" - ± 8,5 mm MQ

LOVE . CAMPITURA PICASSO WARM 2/S



LPW2 - 50x120 RT - 20"x48" - ± 8,5 mm

LOVE . CAMPITURA PICASSO COLD 2/S



LPC2 - 50x120 RT - 20"x48" - ± 8,5 mm

PRKB profilo metallo raku bronze 1x100 RT - 0,4"x40"

PRKD profilo metallo raku dust 1x100 RT - 0,4"x40"

Profili in metallo abbinabili a pag. 251
Metal profiles page 251

PRKG profilo metallo raku green 1x100 RT - 0,4"x40"

PRUK profilo metallo raku dark 1x100 RT - 0,4"x40"

* Per la pulizia si consiglia l'utilizzo di un panno morbido con acqua e sapone neutro. Evitare l'utilizzo di prodotti acidi o alcalini, ceranti, pagliette di metallo o abrasive.
The use of a common mild detergent is recommended. Avoid using acidic or alkaline products, waxes, steel wool, or abrasives.
Nous vous conseillons d'utiliser des détergents neutres courants. Éviter l'utilisation de cires et de produits acides ou alcalins, ainsi que les pailles métalliques ou abrasives.
Es empfiehlt sich, ein haushaltsübliches, neutrales Reinigungsmittel zu verwenden. Saure oder alkalische Produkte, Wachs sowie Metallwolle- bzw. Scheuerschwämme sind zu vermeiden.

LOVE WHITE



LWH2 - 25x75 - 10"x30" - ± 8,5 mm

LOVE BROWN



LBWR - 25x75 - 10"x30" - ± 8,5 mm

LOVE CAMPITURA STRIPES * **



LCS2 - 25x75 - 10"x30" - ± 8,5 mm MQ

LOVE BRONZE



LBRZ - 25x75 - 10"x30" - ± 8,5 mm

LOVE COBALT



LCB2 - 25x75 - 10"x30" - ± 8,5 mm

MPGB profilo glitter bronzo 0,5x75 - 0,2"x30"

MPGA profilo glitter argento 0,5x75 - 0,2"x30"

** Per ottenere il miglior risultato estetico si consiglia di posare la campitura stripes seguendo il verso della freccia posta sul retro della piastrella.
To obtain the best aesthetic result, we recommend to lay campitura stripes following the direction of the arrow on the back of the tile.
Pour obtenir le meilleur résultat esthétique, nous vous recommandons de poser le campitura stripes en suivant le sens de la flèche au dos du carreau.
Um das beste ästhetische Ergebnis zu erzielen, empfehlen wir, das Dekor «campitura stripes» nach der Richtung des Pfeils auf der Rückseite der Fliese zu verlegen.

PAVIMENTI COORDINABILI IN GRES PORCELLANATO | COORDINATE FLOORS TILES PORCELAIN STONEWARE
SOL COORDONNÉ EN GRÈS CÈRAME | KOODINIERTER BODENFLIESEN FEINSTEINZEUG

	LOVE WHITE	LOVE PEARL	LOVE SAND	LOVE COBALT	LOVE BRONZE	LOVE BROWN
COLOVERS (pag. 74)						
HUSK (pag. 130)						
FREEDHOME (pag. 106)						

COLOVERS

GRES PORCELLANATO | PORCELAIN TILE | GRÈS CÉRAME | FEINSTEINZEUG

Pezzi speciali

SPECIAL TILES | PIÈCES SPÉCIALES | FORMTEILE

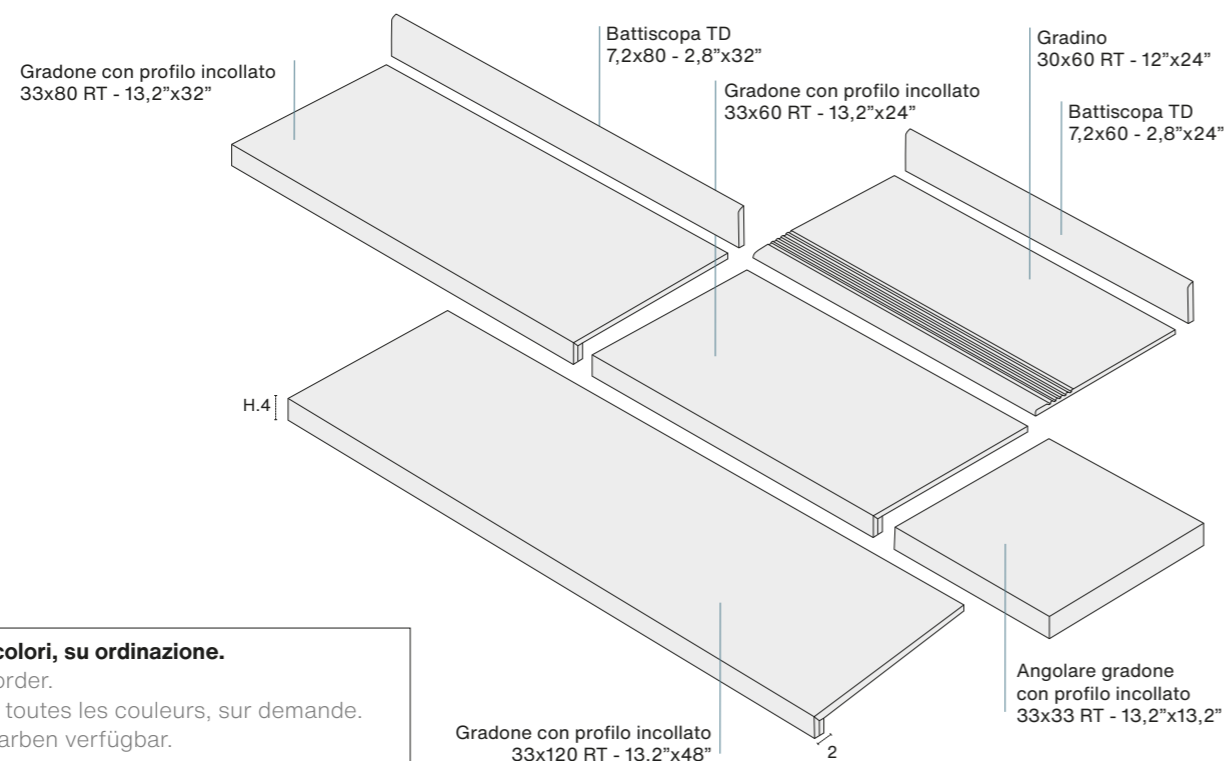
Pezzi speciali disponibili su tutti i colori, su ordinazione.

Trim tiles available in all colors to order.

Pièces spéciales disponibles dans toutes les couleurs, sur demande.

Formteile auf Bestellung in allen Farben verfügbar.

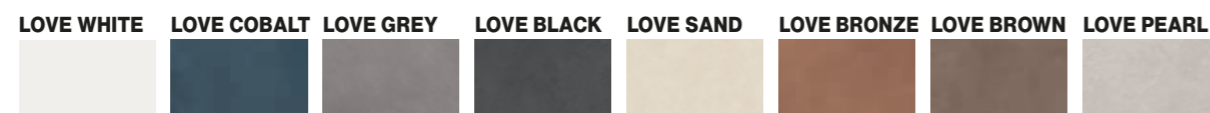

	LOVE WHITE	LOVE COBALT	LOVE GREY	LOVE BLACK	LOVE SAND	LOVE BRONZE	LOVE BROWN	LOVE PEARL
Gradone c/prof. Incollato 33x120 RT	LWG1	LAG1	LGP1	LBG1	LSG1	-	-	LRG1
Gradone c/prof incollato 33x80 RT	-	-	LY8G	-	LS8G	LZ8G	LW8G	LP8G
Gradone c/prof incollato 33x60 RT	LW6G	LC6G	LG6G	LK6G	LS6G	LZ6G	LWG6	LP6G
Ang. Gradone c/prof.inc. 33x33 RT	LH3A	LCA3	LY3A	LK3A	LDA3	LOZ3	LBA3	LEA3
Gradino 30x60 RT	GRLH	LOGR	GYGR	LKGR	LDGR	LZGR	GRBW	GRLP
Battiscopa TD 7,2x80	-	-	LOY8	-	SNB8	LOZ8	LOB8	PEB8
Battiscopa TD 7,2x60	LWB6	LOB6	LGR6	LKB6	LNB6	LZB6	LBB6	LPB6

GRES PORCELLANATO | PORCELAIN TILE | GRÈS CÉRAME | FEINSTEINZEUG

EN 14411 Allegato G . Piastrelle di ceramica pressate a secco con basso assorbimento d'acqua (E ≤ 0,5%)

Gruppo B Ia

Caratteristiche tecniche Technical characteristics	Norma Norms	Superficie Naturale
Resistenza all'abrasione profonda Abrasion resistance	ISO 10545-6	≤ 175 mm ³
Resistenza allo scivolamento Slip resistance	EN 16165 (previously DIN 51130)	R9
Resistenza allo scivolamento Dynamic coefficient of friction (DCOF)	ANSI A326.3	Conforme According to
Coefficiente di attrito dinamico Dynamic friction coefficient	METODO B.C.R.A.	Conforme According to
UPEC	Consultare il sito: Pour plus d'informations consulter:	www.supergres.com/upec
Grado di variazione cromatica Colour shade variation	V1 min - V4 max	V2

Imballi

EMBALLAGE | VERPACKUNG | PACKING

COLOVERS / FLOOR

GRES PORCELLANATO | PORCELAIN TILE | GRÈS CÉRAME | FEINSTEINZEUG

FORMATO	PZ	MQ/PZ	KG/PZ	PZ/CASSA*	MQ/CASSA*	KG/CASSA*	SPESSORE
120x278 RT	1	3,34	49,50	18	60,05	979	6 mm
120x278 RT	1	3,34	49,50	5	16,68	301	6 mm
	* 120x278 fornito in casse di dimensioni 291,6x144,5x33,8 (PxLxH) cm - Peso kg 88 / o in casse per max 5 pz dim.291.6x144.5x24h - peso kg 52.5 * 120x278 supplied in crates. Dimensions crate cm 291,6x144,5x33,8h cm - Weight kg 88 / crates 5 pcs (charge max). Dim.291.6x144.5x24h - Weight kg 52.5						
	PZ	MQ/PZ	KG/PZ	PZ/CAV. **	MQ/CAV. **	KG/CAV. **	SPESSORE
120x278 RT	1	3,34	49,50	18	60,05	1051	6 mm
120x278 RT	1	3,34	49,50	42	140,11	2259	6 mm
	** 120x278 fornito su cavalletti (18 pz o 42 pz - carico max) di dimensioni 290x75x156 (PxLxH) cm - Peso kg 160 ** 120x278 supplied in stand containing (18 pcs or 42 pcs - charge max). Dimensions cm 290x75x156h cm - Weight kg 160						
	PZ/BOX	MQ/BOX	KG/BOX	BOX/PLT	MQ/PLT	KG/PLT	SPESSORE
120x120 RT	2	2,88	60,00	20	57,60	1212	9 mm
60x120 RT	2	1,44	30,00	35	50,40	1065	9 mm
80x80 RT	2	1,28	25,50	48	61,44	1236	9 mm
60x60 RT	3	1,08	22,00	40	43,20	895	9 mm
30x60 RT	7	1,26	25,00	40	50,40	1012	9 mm
30x30 RT mosaico su rete	10	0,90	16,00	30	27,00	495	-
33x120 RT gradone c/pr. incollato	2	-	-	-	-	-	-
33x80 RT gradone c/profilo incollato	2	-	-	-	-	-	-
33x60 RT gradone c/profilo incollato	4	-	-	-	-	-	-
33x33 RT ang/gradone c/pr.inc.	4	-	-	-	-	-	-
30x60 RT gradino	7	-	-	-	-	-	-
7,2x80 battiscopa total dek	8	6,40 ml	7,00	72	460,80 ml	519	-
7,2x60 battiscopa total dek	10	6,00 ml	9,40	70	420 ml	673	-

COLOVERS / WALL

RIVESTIMENTO IN PASTA BIANCA | WHITE BODY WALL TILES | REVÊTEMENTS EN PÂTE BLANCHE | WEISBSCHERBIGER WANDFLIESEN

	PZ/BOX	MQ/BOX	KG/BOX	BOX/PLT	MQ/PLT	KG/PLT	SPESSORE
50x120 RT	3	1,80	26,50	35	63,00	940	8,5 mm
50x120 RT Nest	3	1,80	26,50	35	63,00	940	8,5 mm*
50x120 RT Struttura brush	3	1,80	26,50	35	63,00	940	8,5 mm*
Campitura Ramage	3	1,80	26,50	35	63,00	940	8,5 mm
Campitura Picasso	2	-	-	-	-	-	-
25x75	8	1,50	22,70	42	63,00	968	8,5 mm
25x75 Decoro Stripes	8	1,50	22,70	42	63,00	968	8,5 mm
Profilo 1x100	3	-	-	-	-	-	8 mm
Profilo Glitter 0,5x75	6	-	-	-	-	-	8 mm

* Spessore riferito al fondo liscio equivalente . Thickness refers to the equivalent smooth background
Épaisseur se rapportant au carreau lisse équivalent . Die Stärke bezieht sich auf die entsprechende glatte Grundfliese
AVVERTENZE PER LA POSA - Gres porcellanato
RECOMMENDATIONS FOR INSTALLATION - Porcelain tile

Per la posa del materiale rettificato si prescrive una fuga minima di 2 mm.

As for rectified materials, a minimum joint of 2 mm is required.

Pour la pose du matériau rectifié, il faut réaliser un joint minimum de 2 mm.

Für die Verlegung des geschliffenen Materials ist eine Mindestfuge von 2 mm vorgeschrieben.

Si raccomanda di posare i materiali sfalsati di 20 cm al massimo, mai a metà della loro lunghezza

It is strongly recommended to install the materials in a staggered pattern of a maximum of 20 cm, never at half way its length.

Il est conseillé de poser les matériaux en décalé de 20 cm au maximum, jamais à la moitié de leur longueur.

Es wird empfohlen, die Materialien um höchstens 20 cm versetzt zu verlegen und nie in der Mitte ihrer Länge.

Avvertenze per la posa lastre 120x278RT a pag. 335.

Raccomandation for installation slabs 120x278 RT on page 335.

Recommandations pour la pose des plaques 120x278 à la page 335 . Hinweise zum Verlegen 120x278 RT auf Seite 335.

Ekho



Ekho Silk 19,7x120 RT . 7 3/4"x48"

EKHO

GRES PORCELLANATO | PORCELAIN TILE | GRÈS CÉRAME | FEINSTEINZEUG
EN 14411 Allegato G . Piastrelle di ceramica pressate a secco con basso assorbimento d'acqua (E ≤ 0,5%) | Gruppo B la



19,7x120 RT
R9 A
± 9 mm

SUPERFICIE NATURALE | NATURAL SURFACE FINISH | SURFACE NATURELLE | NATÜRLICHE OBERFLÄCHE



30x120 RT
R11 A+B+C
± 20 mm

Page n. 266

EKHO

Ekho Nut 19,7x120 RT . 7 3/4"x48"



Ekho Gold 19,7x120 RT . 7 3/4"x48"



EKHO

GRES PORCELLANATO | PORCELAIN TILE | GRÈS CÉRAME | FEINSTEINZEUG

GOLD

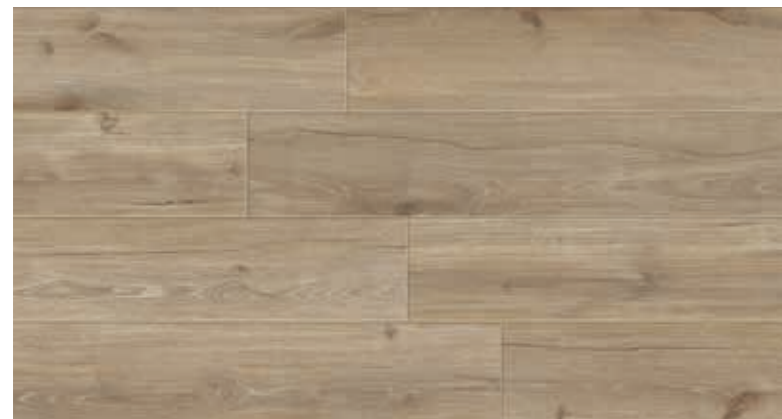

FINITURA NATURALE R9 A		
LDPK	19,7x120 RT - 7 3/4"x48"	± 9 mm
FINITURA STRUTTURATA R11 A+B+C * T.20		
KG20	30x120 RT - 12"x48" T20	± 20 mm

NUT

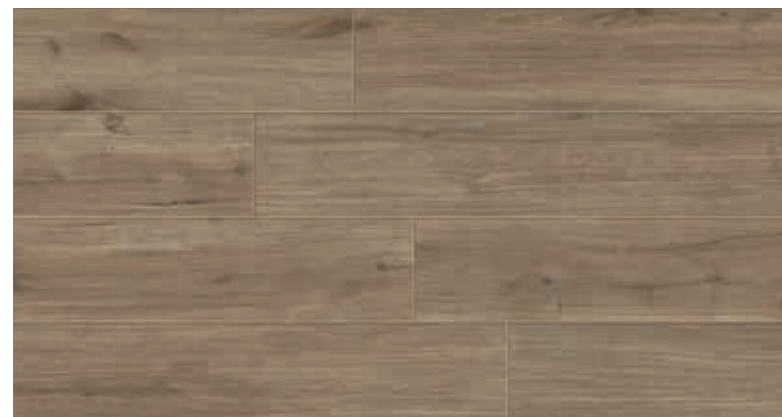

FINITURA NATURALE R9 A		
U2EK	19,7x120 RT - 7 3/4"x48"	± 9 mm
FINITURA STRUTTURATA R11 A+B+C * T.20		
KU20	30x120 RT - 12"x48" T20	± 20 mm

SILK



FINITURA NATURALE R9 A		
2ØPK	19,7x120 RT - 7 3/4"x48"	± 9 mm
FINITURA STRUTTURATA R11 A+B+C * T.20		
SK20	30x120 RT - 12"x48" T20	± 20 mm

Pezzi speciali

SPECIAL TILES | PIÈCES SPÉCIALES | FORMTEILE

	GOLD	SILK	NUT
Battiscopa TD 6x120	EGLB	EKBT	ENBT

Imballi

EMBALLAGE | VERPACKUNG | PACKING

	PZ/BOX	MQ/BOX	KG/BOX	BOX/PLT	MQ/PLT	KG/PLT	SPESSORE
19,7x120 RT	6	1,42	29,00	32	45,39	940	9 mm
6x120 battiscopa total dek	8	9,60 ml	12,00	45	432 ml	552	-

GRES PORCELLANATO | PORCELAIN TILE | GRÈS CÉRAME | FEINSTEINZEUG

EN 14411 Allegato G . Piastrelle di ceramica pressate a secco con basso assorbimento d'acqua (E ≤ 0,5%)

Gruppo B Ia

Caratteristiche tecniche	Norma	Superficie
Technical characteristics	Norms	Naturale
Resistenza all'abrasione profonda Abrasion resistance	ISO 10545-6	≤ 175 mm ³
Resistenza allo scivolamento Slip resistance	EN 16165 (previously DIN 51130)	R9
Resistenza allo scivolamento - Superfici bagnate a piedi scalzi Coefficient of friction - Dry surfaces walking on barefoot	EN 16165 (previously DIN 51097)	A
Resistenza allo scivolamento Dynamic coefficient of friction (DCOF)	ANSI A326.3	Conforme According to
Coefficiente di attrito dinamico Dynamic friction coefficient	METODO B.C.R.A.	Conforme According to
Grado di variazione cromatica Colour shade variation	V1 min - V4 max	V2

AVVERTENZE PER LA POSA - Gres porcellanato

RECOMMENDATIONS FOR INSTALLATION - Porcelain tile

Per la posa del materiale rettificato si prescrive una fuga minima di 2 mm.

As for rectified materials, a minimum joint of 2 mm is required.

Pour la pose du matériau rectifié, il faut réaliser un joint minimum de 2 mm.

Für die Verlegung des geschliffenen Materials ist eine Mindestfuge von 2 mm vorgeschrieben.

Si raccomanda di posare i materiali sfalsati di 20 cm al massimo, mai a metà della loro lunghezza

It is strongly recommended to install the materials in a staggered pattern of a maximum of 20 cm, never at half way its length.

Il est conseillé de poser les matériaux en décalé de 20 cm au maximum, jamais à la moitié de leur longueur.

Es wird empfohlen, die Materialien um höchstens 20 cm versetzt zu verlegen und nie in der Mitte ihrer Länge.

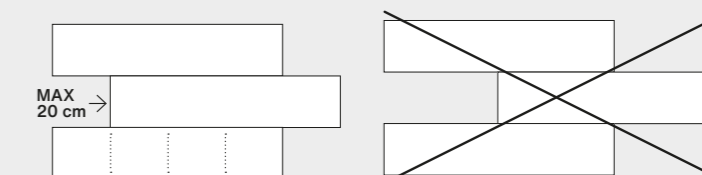

Per maggiori dettagli e aggiornamenti sulle certificazioni, consultare il nostro sito www.supergres.com
 For further details and updated information on certifications, please visit our website www.supergres.com
 Pour obtenir plus d'informations et de mises à jour sur les certifications, veuillez consulter notre site www.supergres.com
 Für weitere Details und Aktualisierungen der Zertifizierungen besuchen Sie bitte unsere Internetseite www.supergres.com

Epika



Epika Shell 60x120RT - 24"x48"

EPIKA

GRES PORCELLANATO | PORCELAIN TILE | GRÈS CÉRAME | FEINSTEINZEUG
 EN 14411 Allegato G . Piastrelle di ceramica pressate a secco con basso assorbimento d'acqua (E ≤ 0,5%) | Gruppo B la

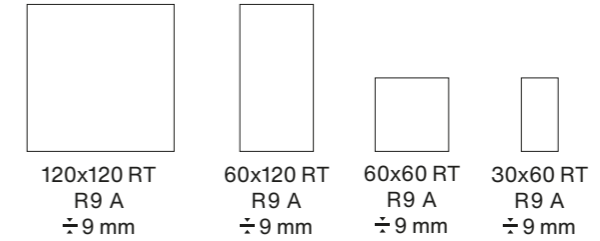

SUPERFICIE NATURALE | NATURAL SURFACE FINISH | SURFACE NATURELLE | NATÜRLICHE OBERFLÄCHE

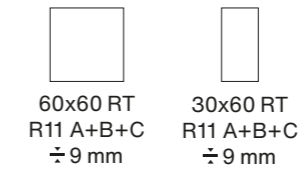

* SUPERFICIE STRUTTURATA | STRUCTURED SURFACE FINISH | FINITION STRUCTURÉE | STRUKTURIERTE OBERFLÄCHE

* **disponibile solo su ordinazione** / available only upon request

EPIKA

GRES PORCELLANATO | PORCELAIN TILE | GRÈS CÉRAME | FEINSTEINZEUG

EPIKA PEARL



FINITURA NATURALE R9 A		
PK12	120x120 RT - 24"x48"	± 9 mm
EPE6	60x120 RT - 32"x32"	± 9 mm
KPE6	60x60 RT - 24"x24"	± 9 mm
EPL3	30x60 RT - 12"x24"	± 9 mm
FINITURA STRUTTURATA R11 A+B+C		
EPST	60x60 RT - 24"x24"	± 9 mm
EPS3	30x60 RT - 12"x24"	± 9 mm
MOSAICI		
EPLK	mosaico losanga dek 30,5x32 - 12"x13"	± 9 mm
PKMS	mosaico su rete 30x30 RT - 12"x12"	± 9 mm



Mosaico Losanga Dek



Mosaico

FORMATO TESSERA
MOSAIC SIZE
4,8x4,8 - 2"x2"

EPIKA SHELL



FINITURA NATURALE R9 A		
SH12	120x120 RT - 24"x48"	± 9 mm
ESH6	60x120 RT - 32"x32"	± 9 mm
KSH6	60x60 RT - 24"x24"	± 9 mm
KSH3	30x60 RT - 12"x24"	± 9 mm
FINITURA STRUTTURATA R11 A+B+C		
EELS	60x60 RT - 24"x24"	± 9 mm
ESS3	30x60 RT - 12"x24"	± 9 mm
MOSAICI		
ESLK	mosaico losanga dek 30,5x32 - 12"x13"	± 9 mm
SKMS	mosaico su rete 30x30 RT - 12"x12"	± 9 mm



Mosaico Losanga Dek



Mosaico

FORMATO TESSERA
MOSAIC SIZE
4,8x4,8 - 2"x2"

EPIKA ALMOND



FINITURA NATURALE R9 A		
EA12	120x120 RT - 24"x48"	± 9 mm
EAL6	60x120 RT - 32"x32"	± 9 mm
KAL6	60x60 RT - 24"x24"	± 9 mm
EAM3	30x60 RT - 12"x24"	± 9 mm
FINITURA STRUTTURATA R11 A+B+C		
KALS	60x60 RT - 24"x24"	± 9 mm
APS3	30x60 RT - 12"x24"	± 9 mm
MOSAICI		
EALK	mosaico losanga dek 30,5x32 - 12"x13"	± 9 mm
AKMS	mosaico su rete 30x30 RT - 12"x12"	± 9 mm



Mosaico Losanga Dek



Mosaico

FORMATO TESSERA
MOSAIC SIZE
4,8x4,8 - 2"x2"

EPIKA GREY



FINITURA NATURALE R9 A		
K6GR	60x60 RT - 24"x24"	± 9 mm
EGY3	30x60 RT - 12"x24"	± 9 mm
FINITURA STRUTTURATA R11 A+B+C		
EPGS	60x60 RT - 24"x24"	± 9 mm
EPG3	30x60 RT - 12"x24"	± 9 mm
MOSAICI		
EGLK	mosaico losanga dek 30,5x32 - 12"x13"	± 9 mm
GKMS	mosaico su rete 30x30 RT - 12"x12"	± 9 mm

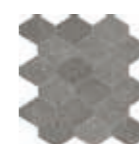

Mosaico Losanga Dek



Mosaico

FORMATO TESSERA
MOSAIC SIZE
4,8x4,8 - 2"x2"

EPIKA CAMEL



FINITURA NATURALE R9 A		
KCA6	60x60 RT - 24"x24"	± 9 mm
KCL3	30x60 RT - 12"x24"	± 9 mm
MOSAICI		
ECLK	mosaico losanga dek 30,5x32 - 12"x13"	± 9 mm
KCMS	mosaico su rete 30x30 RT - 12"x12"	± 9 mm



Mosaico Losanga Dek



Mosaico

FORMATO TESSERA
MOSAIC SIZE
4,8x4,8 - 2"x2"

SUPERFICIE STRUTTURATA disponibile solo su richiesta / available only upon request

EPIKA

GRES PORCELLANATO | PORCELAIN TILE | GRÈS CÉRAME | FEINSTEINZEUG

Pezzi speciali

SPECIAL TILES | PIÈCES SPÉCIALES | FORMTEILE

Pezzi speciali disponibili su tutti i colori, su ordinazione.

Trim tiles available in all colors to order.

Pièces spéciales disponibles dans toutes les couleurs, sur demande.

Formteile auf Bestellung in allen Farben verfügbar.

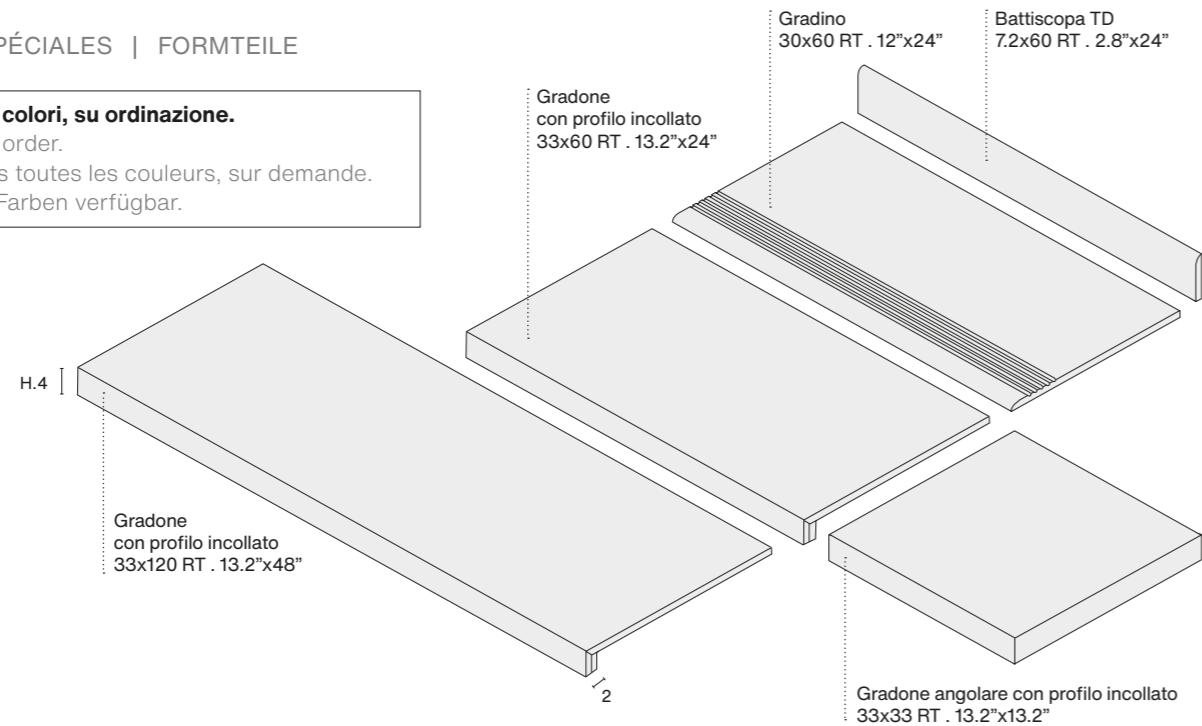

Gradone c/prof. incollato 33x120 RT	-	KPGR	SKGR	KLGR	-
Gradone c/prof. incollato 33x60 RT	GRGK	GRKP	GRKS	GRKA	GRKC
Ang. Gradone c/prof. inc. 33x33 RT	KGGR	PKAG	SKAG	ALAG	CKAG
Gradino 30x60 RT	YGRK	PEGD	HGRE	AGGK	CGD7
Battiscopa TD 7,2x60	GKBT	PKBT	KHBT	KABT	CKBT

GRES PORCELLANATO | PORCELAIN TILE | GRÈS CÉRAME | FEINSTEINZEUG

EN 14411 Allegato G . Piastrelle di ceramica pressate a secco con basso assorbimento d'acqua (E ≤ 0,5%)

Gruppo B la

Caratteristiche tecniche Technical characteristics	Norma Norms	Superficie Naturale	Superficie Strutturata
Resistenza all'abrasione profonda Abrasion resistance	ISO 10545-6	≤ 175 mm ³	≤ 175 mm ³
Resistenza allo scivolamento Slip resistance	EN 16165 (previously DIN 51130)	R9	R11
Resistenza allo scivolamento - Superfici bagnate a piedi scalzi Coefficient of friction - Dry surfaces walking on barefoot	EN 16165 (previously DIN 51097)	A	A+B+C
Resistenza allo scivolamento Dynamic coefficient of friction (DCOF)	ANSI A326.3	Conforme According to	Conforme According to
Coefficiente di attrito dinamico Dynamic friction coefficient	METODO B.C.R.A.	Conforme According to	Conforme According to



Consultare il sito:
Pour plus d'informations consulter:

www.supergres.com/upec

Grado di variazione cromatica
Colour shade variation

V1 min - V4 max

V2

Imballi

EMBALLAGE | VERPACKUNG | PACKING

EPIKA

GRES PORCELLANATO | PORCELAIN TILE | GRÈS CÉRAME | FEINSTEINZEUG

	PZ/BOX	MQ/BOX	KG/BOX	BOX/PLT	MQ/PLT	KG/PLT	SPESSORE
120x120 RT	2	2,88	60,00	20	57,60	1212	9 mm
60x120 RT	2	1,44	30,00	35	50,40	1062	9 mm
60x60 RT / 60x60 RT struttura	3	1,08	22,00	40	43,20	892	9 mm
30x60 RT / 30x60 RT struttura	7	1,26	25,00	40	50,40	1012	9 mm
mosaico su rete 30x30 RT	10	0,90	16,00	30	27,00	495	-
mosaico Losanga Dek 30,5x32	6	0,59	10,00	48	28,11	492	-
battiscopa TD 7,2x60	10	6,00 ml	9,00	70	420 ml	645	-
gradino 30x60	7	-	-	-	-	-	-
gradone c/prof.incollato 33x120 RT	2	-	-	-	-	-	-
gradone c/prof.incollato 33x60 RT	4	-	-	-	-	-	-
ang/grad c/prof.inc. 33x33 RT	4	-	-	-	-	-	-

AVVERTENZE PER LA POSA - Gres porcellanato

RECOMMENDATIONS FOR INSTALLATION - Porcelain tile

Per la posa del materiale rettificato si prescrive una fuga minima di 2 mm.

As for rectified materials, a minimum joint of 2 mm is required.

Pour la pose du matériau rectifié, il faut réaliser un joint minimum de 2 mm.

Für die Verlegung des geschliffenen Materials ist eine Mindestfuge von 2 mm vorgeschrieben.

Si raccomanda di posare i materiali sfalsati di 20 cm al massimo, mai a metà della loro lunghezza

It is strongly recommended to install the materials in a staggered pattern of a maximum of 20 cm, never at half way its length.

Il est conseillé de poser les matériaux en décalé de 20 cm au maximum, jamais à la moitié de leur longueur.

Es wird empfohlen, die Materialien um höchstens 20 cm versetzt zu verlegen und nie in der Mitte ihrer Länge.

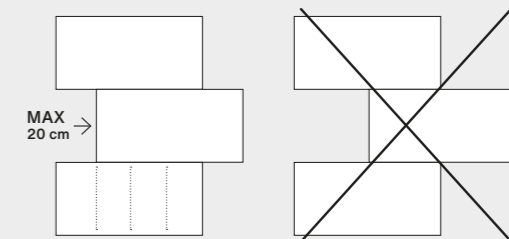

Per maggiori dettagli e aggiornamenti sulle certificazioni, consultare il nostro sito www.supergres.com
For further details and updated information on certifications, please visit our website www.supergres.com
Pour obtenir plus d'informations et de mises à jour sur les certifications, veuillez consulter notre site www.supergres.com
Für weitere Details und Aktualisierungen der Zertifizierungen besuchen Sie bitte unsere Internetseite www.supergres.com

Forth



Chianca 22,5x45,3 . 9"x18"

FORTH

GRES PORCELLANATO | PORCELAIN TILE | GRÈS CÉRAME | FEINSTEINZEUG
EN 14411 Allegato G . Piastrelle di ceramica pressate a secco con basso assorbimento d'acqua (E ≤ 0,5%) | Gruppo B la

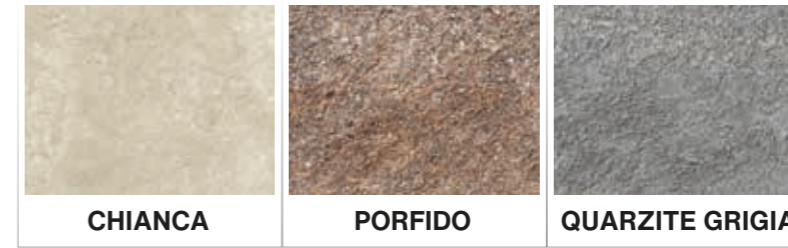

22,5x45,3
R11 A+B+C
÷ 9 mm



22,5x22,5
R11 A+B+C
÷ 9 mm

SUPERFICIE STRUTTURATA | STRUCTURED SURFACE FINISH | FINITION STRUCTURÉE | STRUKTURIERTE OBERFLÄCHE



60x90 RT
R11 A+B+C
÷ 20 mm

Page n. 270

FORTH



Chianca 22,5x45,3 . 9"x18" - 22,5x22,5 . 9"x9"



Porfido 22,5x45,3 . 9"x18" - 22,5x22,5 . 9"x9"



Quarzite T20 60x60RT - 24"x24" - 60x90RT - 24"x36"
Quarzite 22,5x45,3 . 9"x18" - 22,5x22,5 . 9"x9"
Terminale a Elle TD 15x60x4h 6"x12"

FORTH

GRES PORCELLANATO | PORCELAIN TILE | GRÈS CÉRAMÉ | FEINSTEINZEUG

CHIANCA



FINITURA STRUTTURATA R11 A+B+C		
FCH4	22,5x45,3 - 9"x18"	± 9 mm
FINITURA STRUTTURATA R11 A+B+C * T-20		
FCH9	60x90 RT - 24"x36"	± 20 mm

PORFIDO



FINITURA STRUTTURATA R11 A+B+C		
FPO4	22,5x45,3 - 9"x18"	± 9 mm
FHP2	22,5x22,5 - 9"x9"	± 9 mm
FINITURA STRUTTURATA R11 A+B+C * T-20		
FPO9	60x90 RT - 24"x36"	± 20 mm

QUARZITE GRIGIA



FINITURA STRUTTURATA R11 A+B+C		
FQG4	22,5x45,3 - 9"x18"	± 9 mm
FHQ2	22,5x22,5 - 9"x9"	± 9 mm
FINITURA STRUTTURATA R11 A+B+C * T-20		
FQG9	60x90 RT - 24"x36"	± 20 mm

* **Gamma completa Forth T20 a pagina 270 /**
For the complete range Forth T20 go to page 270

Pezzi speciali

SPECIAL TILES | PIÈCES SPÉCIALES | FORMTEILE

	CHIANCA	PORFIDO	QUARZITE GRIGIA
Terminale a Elle TD 15x30x4 h	TLCH	TLPO	TLQG
* Battiscopa TD 7,2x45,3	YFCB	YFPB	YFQB

Imballi

EMBALLAGE | VERPACKUNG | PACKING

	PZ/BOX	MQ/BOX	KG/BOX	BOX/PLT	MQ/PLT	KG/PLT	SPESSORE
22,5x45,3	12	1,22	23,70	34	41,58	820	9 mm
22,5x22,5	20	1,01	19,40	42	42,52	829	9 mm
terminale elle TD	8	0,36	10,75	48	17,28	530	9 mm
battiscopa 7,2x45,3 *	10	4,53 ml	6,80	98	443,94 ml	680	-
60x90 RT	2	1,08	48,00	24	25,92	1167	20 mm

* **disponibili solo su ordinazione** . available only upon request

AVVERTENZE PER LA POSA - Gres porcellanato

RECOMMENDATIONS FOR INSTALLATION - Porcelain tile

I formati 22.5x22.5 e 22.5x45.3 sono studiati per consentire pose modulari: a parità di calibro, si consiglia una fuga di 3 mm. 22.5x22.5 and 22.5x45.3 allows modular layouts, leaving a 3mm joint. La modularité est assurée dans le cas d'une installation avec un joint de 3 mm. Die Zusammenstellbarkeit ist bei der Verlegung mit 3 mm breiter Fuge.

Per maggiori dettagli e aggiornamenti sulle certificazioni, consultare il nostro sito www.supergres.com
For further details and updated information on certifications, please visit our website www.supergres.com
Pour obtenir plus d'informations et de mises à jour sur les certifications, veuillez consulter notre site www.supergres.com
Für weitere Details und Aktualisierungen der Zertifizierungen besuchen Sie bitte unsere Internetseite www.supergres.com

GRES PORCELLANATO | PORCELAIN TILE | GRÈS CÉRAMÉ | FEINSTEINZEUG

EN 14411 Allegato G . Piastrelle di ceramica pressate a secco con basso assorbimento d'acqua (E ≤ 0,5%)

Gruppo B Ia

Caratteristiche tecniche Technical characteristics	Norma Norms	Superficie Naturale
Resistenza all'abrasione profonda Abrasion resistance	ISO 10545-6	≤ 175 mm ³
Resistenza allo scivolamento Slip resistance	EN 16165 (previously DIN 51130)	R11
Resistenza allo scivolamento - Superfici bagnate a piedi scalzi Coefficient of friction - Dry surfaces walking on barefoot	EN 16165 (previously DIN 51097)	A+B+C
Resistenza allo scivolamento Dynamic coefficient of friction (DCOF)	ANSI A326.3	Conforme According to
Coefficiente di attrito dinamico Dynamic friction coefficient	METODO B.C.R.A.	Conforme According to
Grado di variazione cromatica Colour shade variation	V1 min - V4 max	Chianca V2 - Quarzite Grigia V2 Porfido V3

Freedhome



FREEDHOME

GRES PORCELLANATO | PORCELAIN TILE | GRÈS CÉRAMÉ | FEINSTEINZEUG
 EN 14411 Allegato G . Piastrelle di ceramica pressate a secco con basso assorbimento d'acqua ($E \leq 0,5\%$) | Gruppo B la

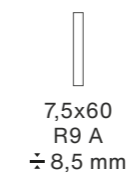
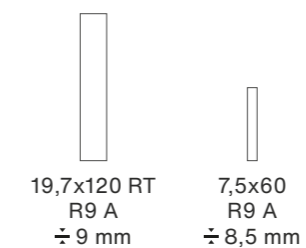

SUPERFICIE NATURALE | NATURAL SURFACE FINISH | SURFACE NATURELLE | NATÜRLICHE OBERFLÄCHE

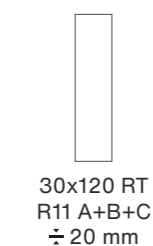
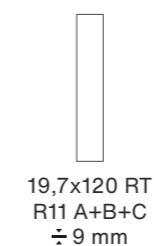

* SUPERFICIE GRIP | SURFACE GRIP | SURFACE GRIP | OBERFLÄCHE GRIP

* **disponibile solo su ordinazione** / available only upon request

T-20 Page n. 274

FREEDHOME

Freedhome Amber 19.7x120RT . 7³/₄"x48"



Freedhome Sand 19.7x120RT . 7³/₄"x48"



FREEDHOME

Freedhome Écru 7.5x60 . 3x24"



Freedhome Honey 19.7x120RT . 7³/₄"x48"



RIVESTIMENTO
Purity Eden lux 120x278 - 48"x 109¹/₂"
serie Purity of marble Elite

PAVIMENTO
Freedhome Tobacco 19.7x120RT . 7³/₄"x48"

FREEDHOME

GRES PORCELLANATO | PORCELAIN TILE | GRÈS CÉRAMÉ | FEINSTEINZEUG

AMBER



FINITURA NATURALE R9 A		
FA20	19,7x120 RT - 7 ³ / ₈ "x48"	± 9 mm
MB60	7,5x60 - 3"x24"	± 8,5 mm
FINITURA GRIP R11 A+B+C **		
FDAG	19,7x120 RT - 7 ³ / ₈ "x48"	± 9 mm
FINITURA STRUTTURATA R11 A+B+C * 		
MB30	30x120 RT - 12"x48" T20	± 20 mm

SAND



FINITURA NATURALE R9 A		
SB20	19,7x120 RT - 7 ³ / ₈ "x48"	± 9 mm
SN60	7,5x60 - 3"x24"	± 8,5 mm
FINITURA GRIP R11 A+B+C **		
FDSG	19,7x120 RT - 7 ³ / ₈ "x48"	± 9 mm
FINITURA STRUTTURATA R11 A+B+C * 		
FD30	30x120 RT - 12"x48" T20	± 20 mm

HONEY

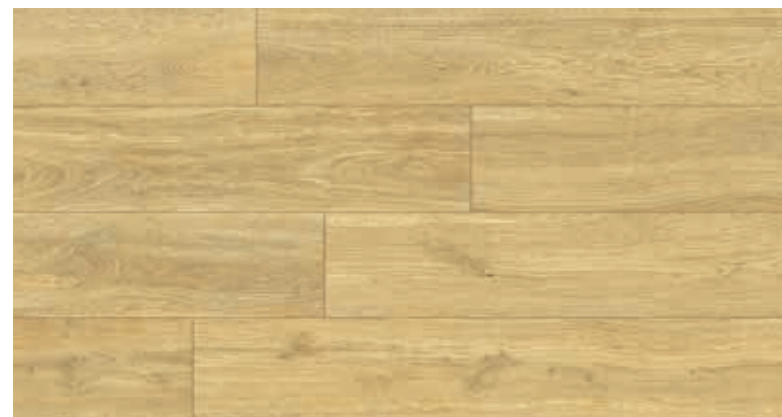

FINITURA NATURALE R9 A		
FDHN	19,7x120 RT - 7 ³ / ₈ "x48"	± 9 mm
FINITURA GRIP R11 A+B+C **		
FDHG	19,7x120 RT - 7 ³ / ₈ "x48"	± 9 mm

TOBACCO



FINITURA NATURALE R9 A		
TC20	19,7x120 RT - 7 ³ / ₈ "x48"	± 9 mm
FINITURA GRIP R11 A+B+C **		
FDTG	19,7x120 RT - 7 ³ / ₈ "x48"	± 9 mm

ÉCRU



FINITURA NATURALE R9 A		
FDE2	19,7x120 RT - 7 ³ / ₈ "x48"	± 9 mm
ER60	7,5x60 - 3"x24"	± 8,5 mm
FINITURA GRIP R11 A+B+C **		
FDEG	19,7x120 RT - 7 ³ / ₈ "x48"	± 9 mm
FINITURA STRUTTURATA R11 A+B+C * 		
FE30	30x120 RT - 12"x48" T20	± 20 mm

* Gamma completa Freedhome T20 a pagina 274 / For the complete range Freedhome T20 go to page 274

** Finitura grip disponibile su richiesta / Grip finish available on request / Finition grip disponible sur demande / Griffausführung auf Anfrage erhältlich

FREEDHOME

GRES PORCELLANATO | PORCELAIN TILE | GRÈS CÉRAME | FEINSTEINZEUG

Pezzi speciali

SPECIAL TILES | PIÈCES SPÉCIALES | FORMTEILE

	AMBER	HONEY	ÉCRU	SAND	TOBACCO
Battiscopa TD 6x120	FDAB	FDHB	FDEB	FDSB	FDTB

GRES PORCELLANATO | PORCELAIN TILE | GRÈS CÉRAME | FEINSTEINZEUG

EN 14411 Allegato G . Piastrelle di ceramica pressate a secco con basso assorbimento d'acqua (E ≤ 0,5%)

Gruppo B la

Caratteristiche tecniche Technical characteristics	Norma Norms	Superficie Naturale	Superficie Grip
Resistenza all'abrasione profonda Abrasion resistance	ISO 10545-6	≤ 175 mm ³	≤ 175 mm ³
Resistenza allo scivolamento Slip resistance	EN 16165 (previously DIN 51130)	R9	R11
Resistenza allo scivolamento - Superfici bagnate a piedi scalzi Coefficient of friction - Dry surfaces walking on barefoot	EN 16165 (previously DIN 51097)	A	A+B+C
Resistenza allo scivolamento Dynamic coefficient of friction (DCOF)	ANSI A326.3	Conforme According to	Conforme According to
Coefficiente di attrito dinamico Dynamic friction coefficient	METODO B.C.R.A.	Conforme According to	Conforme According to
Grado di variazione cromatica Colour shade variation	V1 min - V4 max		V2

Imballi

EMBALLAGE | VERPACKUNG | PACKING

FREEDHOME

GRES PORCELLANATO | PORCELAIN TILE | GRÈS CÉRAME | FEINSTEINZEUG

	PZ/BOX	MQ/BOX	KG/BOX	BOX/PLT	MQ/PLT	KG/PLT	SPESSORE
19,7x120 RT	6	1,42	29,00	32	45,39	940	9 mm
19,7x120 RT grip	6	1,42	29,00	32	45,39	940	9 mm
7,5x60	22	0,99	19,00	60	59,40	1155	8,5 mm
battiscopa TD 6x120	8	9,60 ml	12,00	45	432 ml	552	-

AVVERTENZE PER LA POSA - Gres porcellanato

RECOMMENDATIONS FOR INSTALLATION - Porcelain tile

Per la posa del materiale rettificato si prescrive una fuga minima di 2 mm.

As for rectified materials, a minimum joint of 2 mm is required.

Pour la pose du matériau rectifié, il faut réaliser un joint minimum de 2 mm.

Für die Verlegung des geschliffenen Materials ist eine Mindestfuge von 2 mm vorgeschrieben.

Si raccomanda di posare i materiali sfalsati di 20 cm al massimo, mai a metà della loro lunghezza

It is strongly recommended to install the materials in a staggered pattern of a maximum of 20 cm, never at half way its length.

Il est conseillé de poser les matériaux en décalé de 20 cm au maximum, jamais à la moitié de leur longueur.

Es wird empfohlen, die Materialien um höchstens 20 cm versetzt zu verlegen und nie in der Mitte ihrer Länge.

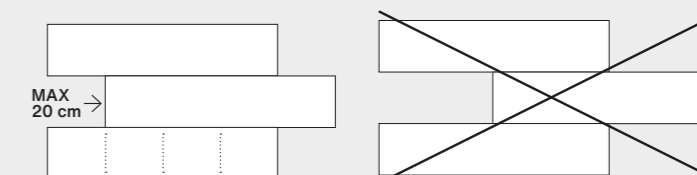

Per maggiori dettagli e aggiornamenti sulle certificazioni, consultare il nostro sito www.supergres.com
For further details and updated information on certifications, please visit our website www.supergres.com
Pour obtenir plus d'informations et de mises à jour sur les certifications, veuillez consulter notre site www.supergres.com
Für weitere Details und Aktualisierungen der Zertifizierungen besuchen Sie bitte unsere Internetseite www.supergres.com

Frenchmood



Chalon 60x120 RT - 24"x48"
Chalon strutt. 60x60 RT - 24"x24"

FRENCHMOOD

GRES PORCELLANATO | PORCELAIN TILE | GRÈS CÉRAMÉ | FEINSTEINZEUG
EN 14411 Allegato G . Piastrelle di ceramica pressate a secco con basso assorbimento d'acqua (E ≤ 0,5%) | Gruppo B la



CHALON

SANT DENIS



60x120 RT
R10 A+B
± 9 mm



60x60 RT
R10 A+B
± 9 mm



30x60 RT
R10 A+B
± 9 mm

SUPERFICIE NATURALE | NATURAL SURFACE FINISH | SURFACE NATURELLE | NATÜRLICHE OBERFLÄCHE



60x60 RT
R11 A+B+C
± 9 mm



30x60 RT
R11 A+B+C
± 9 mm



60x60 RT
R11 A+B+C
± 20 mm

SUPERFICIE STRUTTURATA | STRUCTURED | SURFACE FINISH
FINITION STRUCTURÉE | STRUKTURIERTE OBERFLÄCHE

T.20 Page n. 278

FRENCHMOOD

GRES PORCELLANATO | PORCELAIN TILE | GRÈS CÉRAME | FEINSTEINZEUG

CHALON

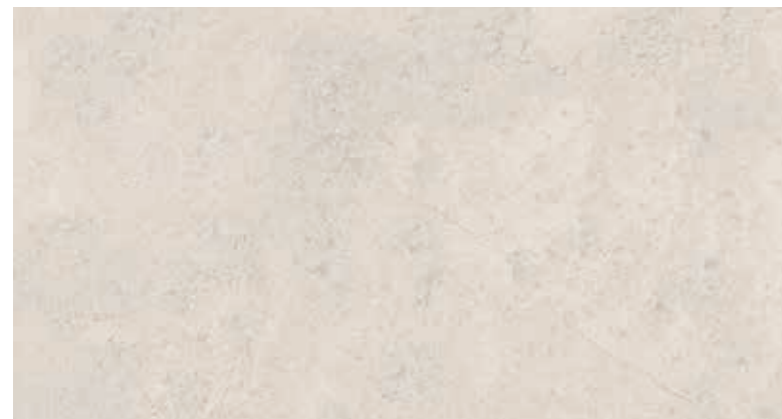

FINITURA NATURALE R10 A+B		
FMH6	60x120 RT - 32"x32"	± 9 mm
CH60	60x60 RT - 24"x24"	± 9 mm
FH30	30x60 RT - 12"x24"	± 9 mm
FINITURA STRUTTURATA R11 A+B+C		
CHS6	60x60 RT - 24"x24"	± 9 mm
CHS3	30x60 RT - 12"x24"	± 9 mm
FINITURA STRUTTURATA R11 A+B+C * T.20		
FCH6	60x60 RT - 24"x24"	± 20 mm
MOSAICI		
CHMS	mosaico 30x30 RT - 12"x12"	± 9 mm



Mosaico

FORMATO TESSERA
MOSAIC SIZE
4,8x4,8 - 2"x2"

SAIN DENIS



FINITURA NATURALE R10 A+B		
FMS6	60x120 RT - 32"x32"	± 9 mm
FS60	60x60 RT - 24"x24"	± 9 mm
FS30	30x60 RT - 12"x24"	± 9 mm
FINITURA STRUTTURATA R11 A+B+C		
SD6S	60x60 RT - 24"x24"	± 9 mm
SD3S	30x60 RT - 12"x24"	± 9 mm
FINITURA STRUTTURATA R11 A+B+C * T.20		
S260	60x60 RT - 24"x24"	± 20 mm
MOSAICI		
SDMS	mosaico 30x30 RT - 12"x12"	± 9 mm



Mosaico

FORMATO TESSERA
MOSAIC SIZE
4,8x4,8 - 2"x2"

Pezzi speciali

SPECIAL TILES | PIÈCES SPÉCIALES | FORMTEILE

	CHALON	SAIN DENIS
Gradone c/prof. incollato 33x120 RT	CHG1	SNG1
Gradone c/prof. incollato 33x60 RT	CHG6	SNG6
Ang. Gradone c/prof. inc. 33x33 RT	GHAG	STAG
Gradino 30x60 RT	GCH7	GSD7
Battiscopa TD 7,2x60	BT6C	SBT6

Imballi

EMBALLAGE | VERPACKUNG | PACKING

FRENCHMOOD

GRES PORCELLANATO | PORCELAIN TILE | GRÈS CÉRAME | FEINSTEINZEUG

	PZ/BOX	MQ/BOX	KG/BOX	BOX/PLT	MQ/PLT	KG/PLT	SPESSORE
60x120 RT	2	1,44	30,00	35	50,40	1062	9 mm
60x60 RT	4	1,44	28,00	30	43,20	852	9 mm
30x60 RT	7	1,26	25,00	40	50,40	1012	9 mm
60x60 RT strutturato	4	1,44	28,00	30	43,20	852	9 mm
30x60 RT strutturato	7	1,26	25,00	40	50,40	1012	9 mm
mosaico su rete 30x30 RT	10	0,90	16,00	30	27,00	495	9 mm
battiscopa TD 7,2x60	10	6,00 ml	9,00	70	420 ml	645	-
gradino 30x60 RT	7	-	-	-	-	-	-
gradone c/prof.incollato 33x120 RT	2	-	-	-	-	-	-
gradone c/prof.incollato 33x60 RT	4	-	-	-	-	-	-
ang/grad c/prof.inc. 33x33 RT	4	-	-	-	-	-	-
60x60 RT	2	0,72	32,00	30	21,60	972	20 mm

GRES PORCELLANATO | PORCELAIN TILE | GRÈS CÉRAME | FEINSTEINZEUG

EN 14411 Allegato G . Piastrelle di ceramica pressate a secco con basso assorbimento d'acqua (E ≤ 0,5%)

Gruppo B Ia

Caratteristiche tecniche Technical characteristics	Norma Norms	Superficie Naturale	Superficie Strutturata
Resistenza all'abrasione profonda Abrasion resistance	ISO 10545-6	≤ 175 mm ³	≤ 175 mm ³
Resistenza allo scivolamento Slip resistance	EN 16165 (previously DIN 51130)	R10	R11
Resistenza allo scivolamento - Superfici bagnate a piedi scalzi Coefficient of friction - Dry surfaces walking on barefoot	EN 16165 (previously DIN 51097)	A+B	A+B+C
Resistenza allo scivolamento Dynamic coefficient of friction (DCOF)	ANSI A326.3	Conforme According to	Conforme According to
Coefficiente di attrito dinamico Dynamic friction coefficient	METODO B.C.R.A.	Conforme According to	Conforme According to
Grado di variazione cromatica Colour shade variation	V1 min - V4 max	V2	

Per maggiori dettagli e aggiornamenti sulle certificazioni, consultare il nostro sito www.supergres.com
For further details and updated information on certifications, please visit our website www.supergres.com
Pour obtenir plus d'informations et de mises à jour sur les certifications, veuillez consulter notre site www.supergres.com
Für weitere Details und Aktualisierungen der Zertifizierungen besuchen Sie bitte unsere Internetseite www.supergres.com

* Gamma completa Astrum T20 a pagina 278 / For the complete range Astrum T20 go to page 278

H24



PAVIMENTO
H.Pearl 120x120 RT - 48"x48"

RIVESTIMENTO
H.Pearl 120x278 RT - 48"x109 1/2"

H24 / FLOOR

GRES PORCELLANATO | PORCELAIN TILE | GRÈS CÉRAME | FEINSTEINZEUG
EN 14411 Allegato G . Piastrelle di ceramica pressate a secco con basso assorbimento d'acqua (E ≤ 0,5%) | Gruppo B la

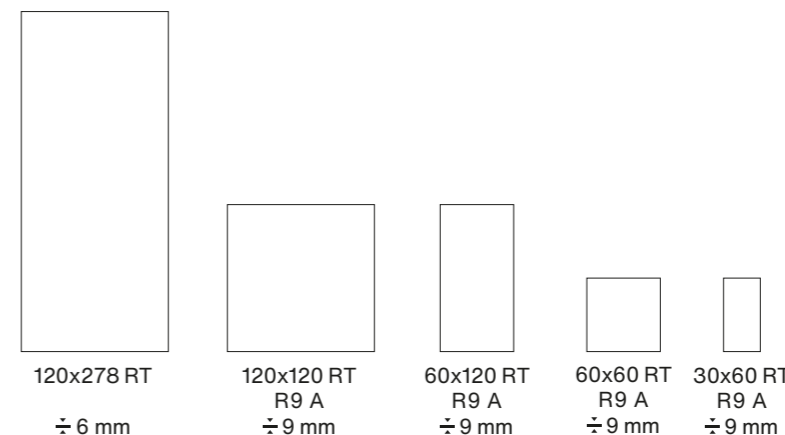
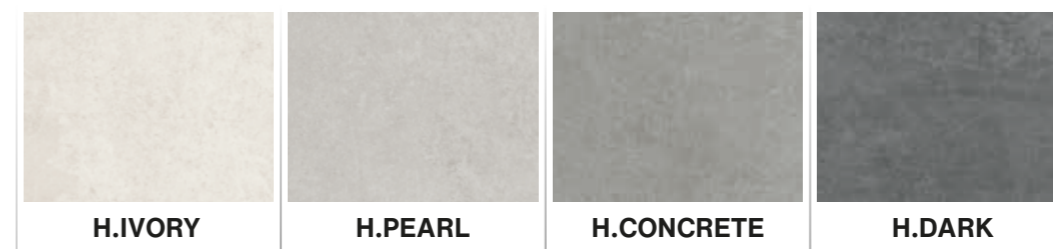

SUPERFICIE NATURALE | NATURAL SURFACE FINISH | SURFACE NATURELLE | NATÜRLICHE OBERFLÄCHE

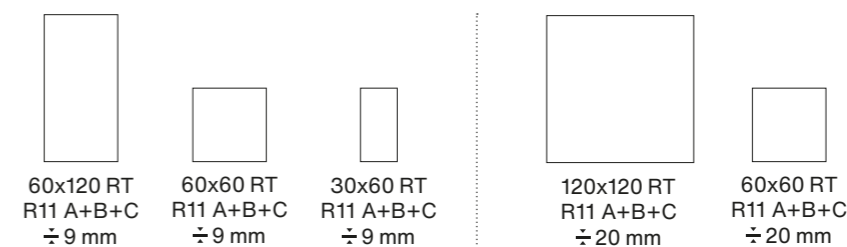

SUPERFICIE GRIP | SURFACE GRIP | SURFACE GRIP | OBERFLÄCHE GRIP

T.20 Page n. 282

H24 / WALL

RIVESTIMENTO IN PASTA BIANCA | WHITE BODY WALL TILES | REVÊTEMENTS EN PÂTE BLANCHE | WEISBSCHERBIGER WANDFLIESEN
EN 14411 Allegato L . Piastrelle di ceramica pressate a secco (E >10%) | Gruppo BIII

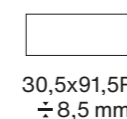

SUPERFICIE SATINATA | SATIN SURFACE FINISH | SURFACE SATINÉE | SATINIERTER OBERFLÄCHE

H24 / FLOOR

GRES PORCELLANATO | PORCELAIN TILE | GRÈS CÉRAME | FEINSTEINZEUG

H.PEARL



120x278 RT FINITURA NATURALE			
HPE8	120x278 RT - 48"x109 ^{1/2} "		± 6 mm
FINITURA NATURALE R9 A			
HGR1	120x120 RT - 48"x48"		± 9 mm
HPE2	60x120 RT - 24"x48"		± 9 mm
HPE6	60x60 RT - 24"x24"		± 9 mm
HPE3	30x60 RT - 12"x24"		± 9 mm
FINITURA GRIP R11 A+B+C			
HPG1	60x120 RT - 24"x48"		± 9 mm
HGP6	60x60 RT - 24"x24"		± 9 mm
HGP3	30x60 RT - 12"x24"		± 9 mm
FINITURA STRUTTURATA R11 A+B+C * T20			
HPT1	120x120 RT - 48"x48" T20		± 20 mm
HPT6	60x60 RT - 24"x24" T20		± 20 mm
MOSAICI			
H24X	mosaico mix 40x40 RT - 16"x16"		± 9 mm
HPEM	mosaico 30x30 RT - 12"x12"		± 9 mm



Mosaico

FORMATO TESSERA
MOSAIC SIZE
4,8x4,8 - 2"x2"

H.IVORY



120x278 RT FINITURA NATURALE			
HLG8	120x278 RT - 48"x109 ^{1/2} "		± 6 mm
FINITURA NATURALE R9 A			
HIV1	120x120 RT - 48"x48"		± 9 mm
HIV2	60x120 RT - 24"x48"		± 9 mm
HIV6	60x60 RT - 24"x24"		± 9 mm
HIV3	30x60 RT - 12"x24"		± 9 mm
MOSAICI			
H24X	mosaico mix 40x40 RT - 16"x16"		± 9 mm
HIVM	mosaico 30x30 RT - 12"x12"		± 9 mm



Mosaico

FORMATO TESSERA
MOSAIC SIZE
4,8x4,8 - 2"x2"



Mosaico Mix

H.CONCRETE



120x278 RT FINITURA NATURALE			
HCC8	120x278 RT - 48"x109 ^{1/2} "		± 6 mm
FINITURA NATURALE R9 A			
HCC1	120x120 RT - 48"x48"		± 9 mm
HCC2	60x120 RT - 24"x48"		± 9 mm
HCC6	60x60 RT - 24"x24"		± 9 mm
HCC3	30x60 RT - 12"x24"		± 9 mm
FINITURA GRIP R11 A+B+C			
HCG1	60x120 RT - 24"x48"		± 9 mm
HGC6	60x60 RT - 24"x24"		± 9 mm
HCG3	30x60 RT - 12"x24"		± 9 mm
FINITURA STRUTTURATA R11 A+B+C * T20			
HCT1	120x120 RT - 48"x48" T20		± 20 mm
HCT6	60x60 RT - 24"x24" T20		± 20 mm
MOSAICI			
H24X	mosaico mix 40x40 RT - 16"x16"		± 9 mm
HCOM	mosaico 30x30 RT - 12"x12"		± 9 mm



Mosaico

FORMATO TESSERA
MOSAIC SIZE
4,8x4,8 - 2"x2"

H.24 CAMP. PAINT



120x278 RT LASTRA DECORATA			
* HCPN	H.24 camp. paint 120x278 RT - 48"x109 ^{1/2} "		± 6 mm

H.24 CAMP. LEAF



120x278 RT LASTRA DECORATA			
* HCLF	H.24 camp. leaf 120x278 RT - 48"x109 ^{1/2} "		± 6 mm

* disponibili solo su ordinazione / available only upon request

H.DARK



FINITURA NATURALE R9 A			
HDK1	120x120 RT - 48"x48"		± 9 mm
HDA2	60x120 RT - 24"x48"		± 9 mm
HDK6	60x60 RT - 24"x24"		± 9 mm
HDK3	30x60 RT - 12"x24"		± 9 mm
FINITURA GRIP R11 A+B+C			
HDG1	60x120 RT - 24"x48"		± 9 mm
HGD6	60x60 RT - 24"x24"		± 9 mm
HDG3	30x60 RT - 12"x24"		± 9 mm
FINITURA STRUTTURATA R11 A+B+C * T20			
HDT1	120x120 RT - 48"x48" T20		± 20 mm
HDT6	60x60 RT - 24"x24" T20		± 20 mm
MOSAICI			
H24X	mosaico mix 40x40 RT - 16"x16"		± 9 mm
HDAM	mosaico 30x30 RT - 12"x12"		± 9 mm



Mosaico

FORMATO TESSERA
MOSAIC SIZE
4,8x4,8 - 2"x2"

H24 / WALL



RIVESTIMENTO
 H.Pearl 30,5x91,5 RT - 12"x36"
 H.Pearl camp. colors 30,5x91,5 RT - 12"x36"
 H.Pearl raw 30,5x91,5 RT - 12"x36"

PAVIMENTO
 Natural Light 19.7x120RT - 7³/₄"x48" serie Natural Appeal

H24 / WALL

RIVESTIMENTO IN PASTA BIANCA | WHITE BODY WALL TILES | REVÊTEMENTS EN PÂTE BLANCHE | WEISBSCHERBIGER WANDFLIESEN

H.PEARL



PEH3 - 30,5x91,5 RT - 12"x36" - ÷ 8,5 mm

H.IVORY



IVH3 - 30,5x91,5 RT - 12"x36" - ÷ 8,5 mm

H.CORAL



CRH3 - 30,5x91,5 RT - 12"x36" - ÷ 8,5 mm

H.JADE

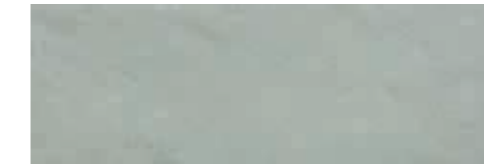

JAH3 - 30,5x91,5 RT - 12"x36" - ÷ 8,5 mm

H.BLUE



BLH3 - 30,5x91,5 RT - 12"x36" - ÷ 8,5 mm

H.PEARL CAMP. DAMASK



HPCD - 30,5x91,5 RT - 12"x36" - ÷ 8,5 mm

H.IVORY CAMP. DAMASK



HICD - 30,5x91,5 RT - 12"x36" - ÷ 8,5 mm

H.CORAL CAMP. DAMASK



HCCD - 30,5x91,5 RT - 12"x36" - ÷ 8,5 mm

H.JADE CAMP. DAMASK



HJCD - 30,5x91,5 RT - 12"x36" - ÷ 8,5 mm

H.BLUE CAMP. DAMASK



HBCD - 30,5x91,5 RT - 12"x36" - ÷ 8,5 mm

H24 / WALL



RIVESTIMENTO
 H.Ivory 30,5x91,5 RT - 12"x36"
 H.Ivory Str. Level 30,5x91,5 RT - 12"x36"
 Profilo Metallo Glitter Gold 1x100 - 0,4"x20"

PAVIMENTO
 H.24 Mosaico Mix 40x40 - 16"x16"

H24 / WALL

RIVESTIMENTO IN PASTA BIANCA | WHITE BODY WALL TILES | REVÊTEMENTS EN PÂTE BLANCHE | WEISBSCHERBIGER WANDFLIESEN

H.PEARL . STRUTTURA LEVEL



HPLV - 30,5x91,5 RT - 12"x36" - ± 8,5 mm MQ

H.PEARL . RAW



HPRW - 30,5x91,5 RT - 12"x36" - ± 8,5 mm MQ

H.IVORY . STRUTTURA LEVEL



HILV - 30,5x91,5 RT - 12"x36" - ± 8,5 mm MQ

H.IVORY . RAW



HIRW - 30,5x91,5 RT - 12"x36" - ± 8,5 mm MQ

H.PEARL . CAMP. COLORS

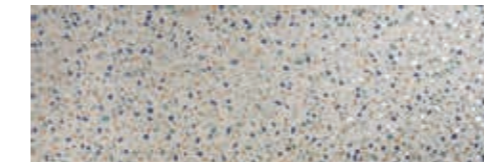

HPCC - 30,5x91,5 RT - 12"x36" - ± 8,5 mm

H.IVORY . CAMP. COLORS



HICC - 30,5x91,5 RT - 12"x36" - ± 8,5 mm

PMGG profilo metallo glitter gold 1x100 RT - 0,4"x40"

PMGS profilo metallo glitter silver 1x100 RT - 0,4"x40"

Profili in metallo abbinabili a pag. 251
 Metal profiles page 251

PMGI profilo metallo glitter iron 1x100 RT - 0,4"x40"

PAVIMENTI COORDINABILI IN GRES PORCELLANATO | COORDINATE FLOORS TILES PORCELAIN STONEWARE
 SOL COORDONNÉ EN GRÉS CÈRAME | KOODINIERTE BODENFLIESEN FEINSTEINZEUG

	H.PEARL	H.IVORY	H.CORAL	H.JADE	H.BLUE
H.24 (pag. 120)					
FREEDHOME (pag. 106)					
NATURAL APPEAL (pag. 148)					

H24

GRES PORCELLANATO | PORCELAIN TILE | GRÈS CÉRAME | FEINSTEINZEUG

Pezzi speciali

SPECIAL TILES | PIÈCES SPÉCIALES | FORMTEILE

Pezzi speciali disponibili su tutti i colori, su ordinazione.

Trim tiles available in all colors to order.

Pièces spéciales disponibles dans toutes les couleurs, sur demande.

Formteile auf Bestellung in allen Farben verfügbar.

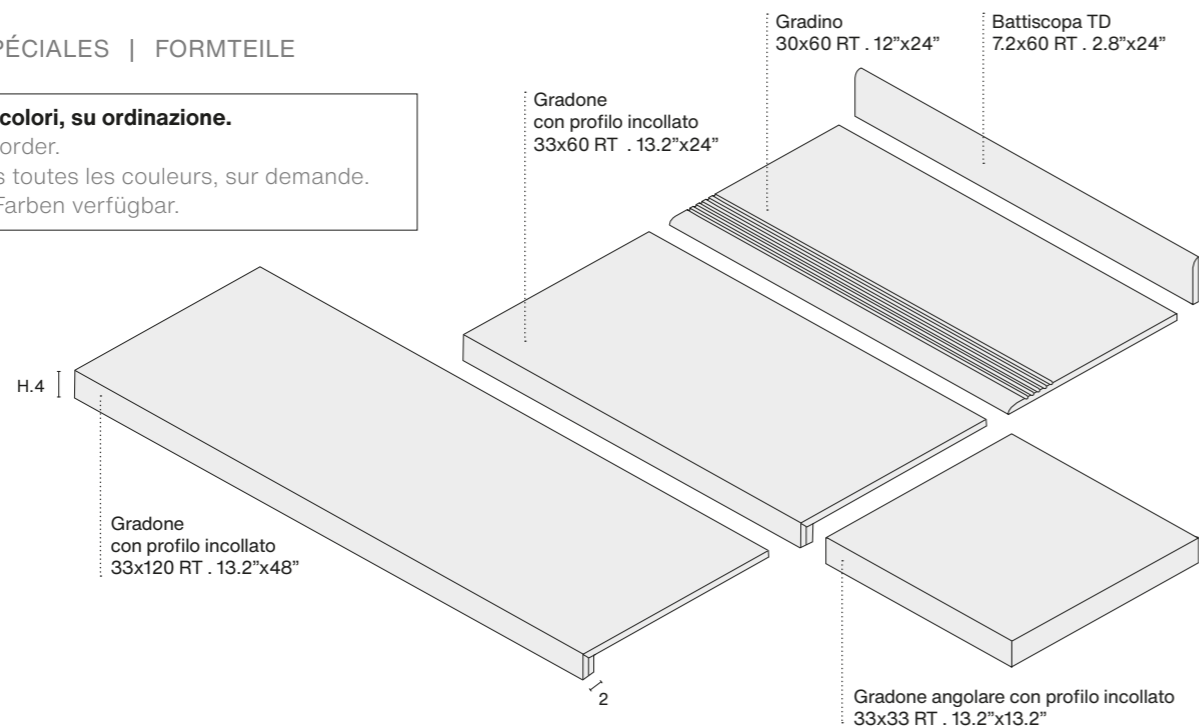

H.IVORY



H.PEARL



H.CONCRETE



H.DARK



Gradone c/prof. incollato 33x120 RT	HIGR	HPGR	HCGR	HDGR
Gradone c/prof. incollato 33x60 RT	HIG6	HPG6	HCG6	HDG6
Ang. Gradone c/prof. inc. 33x33 RT	HIAG	HPAG	HCAg	HDAG
Gradino 30x60 RT	HIVG	HOEG	HCOG	HDKG
Battiscopa TD 7,2x60	HIBT	HPBT	HCBT	HDBT

GRES PORCELLANATO | PORCELAIN TILE | GRÈS CÉRAME | FEINSTEINZEUG

EN 14411 Allegato G . Piastrelle di ceramica pressate a secco con basso assorbimento d'acqua (E ≤ 0,5%)

Gruppo B Ia

Caratteristiche tecniche Technical characteristics	Norma Norms	Superficie Naturale	Superficie Grip
Resistenza all'abrasione profonda Abrasion resistance	ISO 10545-6	≤ 175 mm ³	≤ 175 mm ³
Resistenza allo scivolamento Slip resistance	EN 16165 (previously DIN 51130)	R9	R11
Resistenza allo scivolamento - Superfici bagnate a piedi scalzi Coefficient of friction - Dry surfaces walking on barefoot	EN 16165 (previously DIN 51097)	A	A+B+C
Resistenza allo scivolamento Dynamic coefficient of friction (DCOF)	ANSI A326.3	Conforme According to	Conforme According to
Coefficiente di attrito dinamico Dynamic friction coefficient	METODO B.C.R.A.	Conforme According to	Conforme According to
Grado di variazione cromatica Colour shade variation	V1 min - V4 max	V2	

Imballi

EMBALLAGE | VERPACKUNG | PACKING

H24 / FLOOR

GRES PORCELLANATO | PORCELAIN TILE | GRÈS CÉRAME | FEINSTEINZEUG

FORMATO	PZ	MQ/PZ	KG/PZ	PZ/CASSA*	MQ/CASSA*	KG/CASSA*	SPESSORE
120x278 RT	1	3,34	49,50	18	60,05	979	6 mm
120x278 RT	1	3,34	49,50	5	16,68	301	6 mm



* 120x278 fornito in casse di dimensioni 291,6x144,5x33,8 (PxLxH) cm - Peso kg 88 / o in casse per max 5 pz dim.291.6x144.5x24h - peso kg 52.5

* 120x278 supplied in crates. Dimensions crate cm 291,6x144,5x33,8h cm - Weight kg 88 / crates 5 pcs (charge max). Dim.291.6x144.5x24h - Weight kg 52.5

	PZ	MQ/PZ	KG/PZ	PZ/CAV. **	MQ/CAV. **	KG/CAV. **	SPESSORE
120x278 RT	1	3,34	49,50	18	60,05	1051	6 mm
120x278 RT	1	3,34	49,50	42	140,11	2239	6 mm



** 120x278 fornito su cavalletti (18 pz o 42 pz - carico max) di dimensioni 290x75x156 (PxLxH) cm - Peso kg 160

** 120x278 supplied in stand containing (18 pcs or 42 pcs - charge max). Dimensions cm 290x75x156h cm - Weight kg 160

	PZ/BOX	MQ/BOX	KG/BOX	BOX/PLT	MQ/PLT	KG/PLT	SPESSORE
120x120 RT	2	2,88	60,00	20	57,60	1212	9 mm
60x120 RT / 60x120 RT grip	2	1,44	30,00	35	50,40	1062	9 mm
60x60 RT / 60x60 RT grip	3	1,08	22,00	40	43,20	892	9 mm
30x60 RT / 30x60 RT grip	7	1,26	25,00	40	50,40	1012	9 mm
30x30 RT mosaico su rete	10	0,90	16,00	30	27,00	495	-
40x40 mosaico MIX	6	0,96	18,00	16	15,36	300	-
33x120 RT gradone c/pr. inc.	2	-	-	-	-	-	-
33x60 RT gradone c/profilo incollato	4	-	-	-	-	-	-
33x33 RT ang/gradone c/pr.inc.	4	-	-	-	-	-	-
30x60 RT gradino	7	-	-	-	-	-	-
7,2x60 battiscopa total dek	10	6,00 ml	9,40	70	420 ml	673	-

H24/ WALL

RIVESTIMENTO IN PASTA BIANCA | WHITE BODY WALL TILES | REVÊTEMENTS EN PÂTE BLANCHE | WEISBSCHERBIGER WANDFLIESEN

	PZ/BOX	MQ/BOX	KG/BOX	BOX/PLT	MQ/PLT	KG/PLT	SPESSORE
30,5x91,5RT	5	1,395	21,00	42	58,59	894	8,5 mm
30,5x91,5RT raw	5	1,395	21,00	42	58,59	894	8,5 mm*
30,5x91,5RT struttura level	4	1,116	20,50	42	46,87	873	8,5 mm*
30,5x91,5RT campitura	2	-	-	-	-	-	-
profilo metallo/glitter 1x100	3	-	-	-	-	-	8 mm

* Spessore riferito al fondo liscio equivalente . Thickness refers to the equivalent smooth background
Épaisseur se rapportant au carreau lisse équivalent . Die Stärke bezieht sich auf die entsprechende glatte Grundfliese

AVVERTENZE PER LA POSA - Gres porcellanato

RECOMMENDATIONS FOR INSTALLATION - Porcelain tile

Per la posa del materiale rettificato si prescrive una fuga minima di 2 mm. As for rectified materials, a minimum joint of 2 mm is required. Pour la pose du matériau rectifié, il faut réaliser un joint minimum de 2 mm. Für die Verlegung des geschliffenen Materials ist eine Mindestfuge von 2 mm vorgeschrieben.

Si raccomanda di posare i materiali sfalsati di 20 cm al massimo, mai a metà della loro lunghezza. It is strongly recommended to install the materials in a staggered pattern of a maximum of 20 cm, never at half way its length. Il est conseillé de poser les matériaux en décalé de 20 cm au maximum, jamais à la moitié de leur longueur. Es wird empfohlen, die Materialien um höchstens 20 cm versetzt zu verlegen und nie in der Mitte ihrer Länge.

Avvertenze per la posa lastre 120x278RT a pag. 335 . Raccomandation for installation slabs 120x278 RT on page 335 . Recommandations pour la pose des plaques 120x278 à la page 335 . Hinweise zum Verlegen 120x278 RT auf Seite 335.

Per maggiori dettagli e aggiornamenti sulle certificazioni, consultare il nostro sito www.supergres.com
For further details and updated information on certifications, please visit our website www.supergres.com
Pour obtenir plus d'informations et de mises à jour sur les certifications, veuillez consulter notre site www.supergres.com
Für weitere Details und Aktualisierungen der Zertifizierungen besuchen Sie bitte unsere Internetseite www.supergres.com

Husk



PAVIMENTO
Husk greige 19,7x120 RT - 7³/₄"x48"

RIVESTIMENTO
Capraia Lux 120x278 RT - 48"x109¹/₂"
serie Purity of Marble

HUSK

GRES PORCELLANATO | PORCELAIN TILE | GRÈS CÉRAMÉ | FEINSTEINZEUG
EN 14411 Allegato G . Piastrelle di ceramica pressate a secco con basso assorbimento d'acqua (E ≤ 0,5%) | Gruppo B la

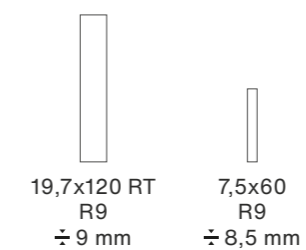

SUPERFICIE NATURALE | NATURAL SURFACE FINISH | SURFACE NATURELLE | NATÜRLICHE OBERFLÄCHE

HUSK

Husk Nut 7,5x60 . 3"x24"



Husk light 19,7x120 RT . 7³/₄"x48" - 29,7x120 RT . 11⁷/₈"x48"



Husk Forest 19,7x120 RT . 7³/₄"x48"



HUSK

GRES PORCELLANATO | PORCELAIN TILE | GRÈS CÉRAME | FEINSTEINZEUG

HUSK LIGHT

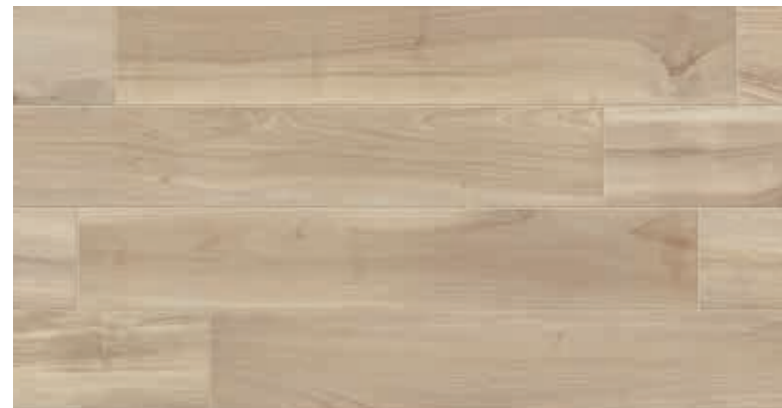

FINITURA NATURALE R9		
HUL2	19,7x120 RT - 7 3/4"x48"	± 9 mm
HLG6	7,5x60 - 3"x24"	± 8,5 mm

HUSK GREIGE



FINITURA NATURALE R9		
HUG2	19,7x120 RT - 7 3/4"x48"	± 9 mm

HUSK NUT

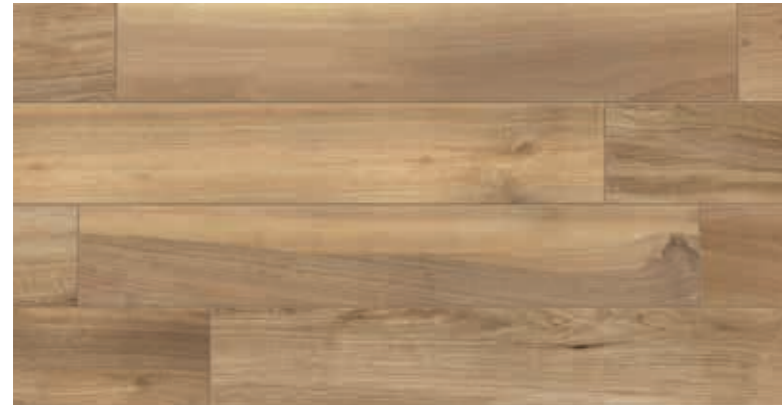

FINITURA NATURALE R9		
HUN2	19,7x120 RT - 7 3/4"x48"	± 9 mm
HNU6	7,5x60 - 3"x24"	± 8,5 mm

HUSK FOREST



FINITURA NATURALE R9		
HUF2	19,7x120 RT - 7 3/4"x48"	± 9 mm
HF06	7,5x60 - 3"x24"	± 8,5 mm

Pezzi speciali

SPECIAL TILES | PIÈCES SPÉCIALES | FORMTEILE

	HUSK LIGHT	HUSK GREIGE	HUSK NUT	HUSK FOREST
Battiscopa TD 6x120	HL6B	HG6B	HN6B	HF6B

Imballi

EMBALLAGE | VERPACKUNG | PACKING

HUSK

GRES PORCELLANATO | PORCELAIN TILE | GRÈS CÉRAME | FEINSTEINZEUG

	PZ/BOX	MQ/BOX	KG/BOX	BOX/PLT	MQ/PLT	KG/PLT	SPESSORE
19,7x120 RT	6	1,42	29,00	32	45,39	940	9 mm
7,5x60	22	0,99	19,00	60	59,40	1155	8,5 mm
6x120 battiscopa total dek	8	9,60 ml	12,00	45	432 ml	552	-

GRES PORCELLANATO | PORCELAIN TILE | GRÈS CÉRAME | FEINSTEINZEUG

EN 14411 Allegato G . Piastrelle di ceramica pressate a secco con basso assorbimento d'acqua (E ≤ 0,5%)

Gruppo B la

Caratteristiche tecniche Technical characteristics	Norma Norms	Superficie Naturale
Resistenza all'abrasione profonda Abrasion resistance	ISO 10545-6	≤175 mm ³
Resistenza allo scivolamento Slip resistance	EN 16165 (previously DIN 51130)	R9
Resistenza allo scivolamento Dynamic coefficient of friction (DCOF)	ANSI A326.3	Conforme According to
Coefficiente di attrito dinamico Dynamic friction coefficient	METODO B.C.R.A.	Conforme According to
Grado di variazione cromatica Colour shade variation	V1 min - V4 max	V2

AVVERTENZE PER LA POSA - Gres porcellanato

RECOMMENDATIONS FOR INSTALLATION - Porcelain tile

Per la posa del materiale rettificato si prescrive una fuga minima di 2 mm.

As for rectified materials, a minimum joint of 2 mm is required.

Pour la pose du matériau rectifié, il faut réaliser un joint minimum de 2 mm.

Für die Verlegung des geschliffenen Materials ist eine Mindestfuge von 2 mm vorgeschrieben.

Si raccomanda di posare i materiali sfalsati di 20 cm al massimo, mai a metà della loro lunghezza

It is strongly recommended to install the materials in a staggered pattern of a maximum of 20 cm, never at half way its length.

Il est conseillé de poser les matériaux en décalé de 20 cm au maximum, jamais à la moitié de leur longueur.

Es wird empfohlen, die Materialien um höchstens 20 cm versetzt zu verlegen und nie in der Mitte ihrer Länge.

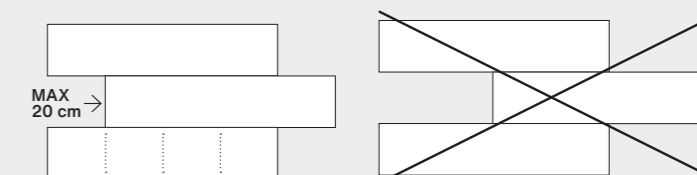

Per maggiori dettagli e aggiornamenti sulle certificazioni, consultare il nostro sito www.supergres.com
 For further details and updated information on certifications, please visit our website www.supergres.com
 Pour obtenir plus d'informations et de mises à jour sur les certifications, veuillez consulter notre site www.supergres.com
 Für weitere Details und Aktualisierungen der Zertifizierungen besuchen Sie bitte unsere Internetseite www.supergres.com

Medley



RIVESTIMENTO
Struttura Mark 25x75 - 10"x30"
Medley Struttura Mark mix 25x75 - 10"x30"

PAVIMENTO
Natural Wild Strutturato 19,7x120 RT - 7 3/4"x48" - serie Natural Appeal

MEDLEY/ WALL

RIVESTIMENTO IN PASTA BIANCA | WHITE BODY WALL TILES | REVÊTEMENTS EN PÂTE BLANCHE | WEISBSCHERBIGER WANDFLIESEN
EN 14411 Allegato L . Piastrelle di ceramica pressate a secco (E >10%) | Gruppo Bill



25x75
± 8,5 mm

SUPERFICIE SATINATA | SATIN SURFACE FINISH | SURFACE SATINÉE | SATINIERTE OBERFLÄCHE

MEDLEY

RIVESTIMENTO
Greige 25x75 . 10"x30"
Greige struttura mark 25x75 . 10"x30"
Greige campitura origami 25x75 . 10"x30"

PAVIMENTO
Greige 75x75 RT . 30"x30"



MEDLEY / WALL

RIVESTIMENTO IN PASTA BIANCA | WHITE BODY WALL TILES | REVÊTEMENTS EN PÂTE BLANCHE | WEISßSCHERBIGER WANDFLIESEN

01 SUGAR

01S2 - **25x75** - 10"x30" - ÷ 8,5 mm

01 SUGAR . STRUTTURA BLOCK

01B2 - **25x75** - 10"x30"

02 SAND

02S2 - **25x75** - 10"x30" - ÷ 8,5 mm

02 SAND . STRUTTURA BLOCK

02B2 - **25x75** - 10"x30"

03 GREIGE

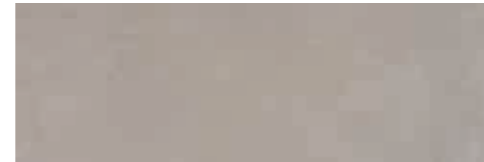
MD3G - **25x75** - 10"x30" - ÷ 8,5 mm

03 GREIGE . STRUTTURA BLOCK

03B3 - **25x75** - 10"x30"

01 SUGAR . STRUTTURA MARK

01SM - **25x75** - 10"x30"

02 SAND . STRUTTURA MARK

02SK - **25x75** - 10"x30"

03 GREIGE . STRUTTURA MARK

03MK - **25x75** - 10"x30"

MEDLEY . STRUTTURA MARK DEK MIX

MRT2 - **25x75** - 10"x30"

Per ottenere il miglior risultato estetico si consiglia di posare la Medley struttura mark mix seguendo il verso della freccia posta sul retro della piastrella.

To obtain the best aesthetic result, we recommend to lay Medley struttura Mark mix following the direction of the arrow on the back of the tile.

Pour obtenir le meilleur résultat esthétique, nous vous recommandons de poser le Medley struttura mark mix en suivant le sens de la flèche au dos du carreau.

Um das beste ästhetische Ergebnis zu erzielen, empfehlen wir, das Dekor «Medley Structure Mark Mix» nach der Richtung des Pfeils auf der Rückseite der Fliese zu verlegen.

01 SUGAR . CAMPITURA RAMAGE

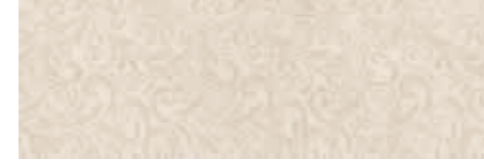
M01R - **25x75** - 10"x30" - ÷ 8,5 mm

02 SAND . CAMPITURA RAMAGE

M02R - **25x75** - 10"x30" - ÷ 8,5 mm

03 GREIGE . CAMPITURA RAMAGE

M03R - **25x75** - 10"x30" - ÷ 8,5 mm

03 GREIGE . CAMP. ORIGAMI

M03O - **25x75** - 10"x30" - ÷ 8,5 mm

PMAR profilo metallo argento **0,5x100 RT** - 0,2"x40"

PMOR profilo metallo oro **0,5x100 RT** - 0,2"x40"

Profili in metallo abbinabili a pag. 251
Metal profiles page 251

PMRA profilo metallo rame **0,5x100 RT** - 0,2"x40"

MEDLEY / WALL

RIVESTIMENTO IN PASTA BIANCA | WHITE BODY WALL TILES | REVÊTEMENTS EN PÂTE BLANCHE | WEISßSCHERBIGER WANDFLIESEN

	PZ/BOX	MQ/BOX	KG/BOX	BOX/PLT	MQ/PLT	KG/PLT	SPESSORE
25x75	8	1,50	22,70	42	63,00	968	8,5 mm
25x75 struttura mark	7	1,312	21,00	42	55,13	894	8,5 mm*
25x75 struttura mark dek mix	7	1,312	21,00	42	55,13	894	8,5 mm*
25x75 struttura block	7	1,312	21,00	42	55,13	894	8,5 mm*
25x75 campitura ramage	4	-	-	-	-	-	-
25x75 campitura origami	4	-	-	-	-	-	-
0,5x100 profilo metallo	3	-	-	-	-	-	8 mm

* Spessore riferito al fondo liscio equivalente . Thickness refers to the equivalent smooth background
Épaisseur se rapportant au carreau lisse équivalent . Die Stärke bezieht sich auf die entsprechende glatte Grundfliese

PAVIMENTI COORDINABILI IN GRES PORCELLANATO | COORDINATE FLOORS TILES PORCELAIN STONWARE
SOL COORDONNÉ EN GRÉS CÈRAME | KOODINIERTE BODENFLIESEN FEINSTEINZEUG

	01 SUGAR	02 SAND	03 GREIGE
HUSK (pag. 130)			
	HUSK LIGHT	HUSK NUT	HUSK GREIGE
FREEDHOME (pag. 106)			
	HONEY	AMBER	ÉCRU
COLOVERS (pag. 74)			
	LOVE SAND	LOVE BROWN	LOVE PEARL

Met-All



RIVESTIMENTO
Met-light twist 30.5x91.5RT
Met-light camp.oro 30.5x91.5RT
Profilo metallo oro 0.5x100 0.2"x40"

PAVIMENTO
Natural Almond 19.7x120Rt 7 3/4"x48" - serie Natural Appeal

MET-ALL / WALL

RIVESTIMENTO IN PASTA BIANCA | WHITE BODY WALL TILES | REVÊTEMENTS EN PÂTE BLANCHE | WEISBSCHERBIGER WANDFLIESEN
EN 14411 Allegato L . Piastrelle di ceramica pressate a secco (E >10%) | Gruppo BIII

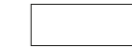

30,5x91,5 RT
± 8,5 mm

SUPERFICIE SATINATA | SATIN SURFACE FINISH | SURFACE SATINÉE | SATINIERTE OBERFLÄCHE

MET-ALL

RIVESTIMENTO
Met-Pearl 30,5x91,5 RT 12"x36"
Met-Grey 30,5x91,5 RT 12"x36"
Met-Pearl Str. Move 30,5x91,5 RT 12"x36"
Mosaico Grey Shine 30x30 RT 12"x12"

PAVIMENTO
Met-Pearl 75x75 RT 30"x30"



RIVESTIMENTO
Met-Avio 30,5x91,5 RT 12"x36"
Met-Light 30,5x91,5 RT 12"x36"
Met-Light Str. Move 30,5x91,5 RT 12"x36"
Mosaico White Shine 30x30 RT 12"x12"

PAVIMENTO
Met-Light 75x75 RT 30"x30"



RIVESTIMENTO
Met-Pearl Twist 30,5x91,5 RT 12"x36"
Met-Sage 30,5x91,5 RT 12"x36"
Met-Sage/Avio Campitura Rame 30,5x91,5 RT 12"x36"

PAVIMENTO
Met-Pearl 75x150 RT 30"x60"



MET-ALL / WALL

RIVESTIMENTO IN PASTA BIANCA | WHITE BODY WALL TILES | REVÊTEMENTS EN PÂTE BLANCHE | WEISßSCHERBIGER WANDFLIESEN

MET-LIGHT



MTL9 - 30,5x91,5 RT -12"x36" - ÷ 8,5 mm

MET-PEARL

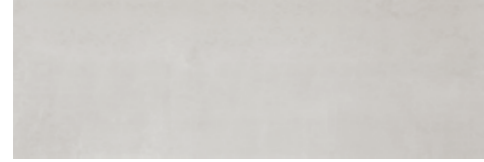

MPR9 - 30,5x91,5 RT -12"x36" - ÷ 8,5 mm

MET-GREY



MGY9 - 30,5x91,5 RT -12"x36" - ÷ 8,5 mm

MET-SAGE



MSA9 - 30,5x91,5 RT -12"x36" - ÷ 8,5 mm

MET-AVIO



MAV9 - 30,5x91,5 RT -12"x36" - ÷ 8,5 mm

MET-LIGHT . TWIST



MLTW - 30,5x91,5 RT -12"x36"



MET-PEARL . TWIST



MPTW - 30,5x91,5 RT -12"x36"



MET-LIGHT . STRUTTURA MOVE



MLMV - 30,5x91,5 RT -12"x36"



MET-PEARL . STRUTTURA MOVE



MPMV - 30,5x91,5 RT -12"x36"



MET-LIGHT . CAMP. ORO



MLCO - 30,5x91,5 RT -12"x36"

PEARL/GREY . CAMP. ARGENTO



MPCR - 30,5x91,5 RT -12"x36" - ÷ 8,5 mm

MET-SAGE/AVIO . CAMP. RAME



MSCR - 30,5x91,5 RT -12"x36"

Imballi

EMBALLAGE | VERPACKUNG | PACKING

MET-ALL / WALL

RIVESTIMENTO IN PASTA BIANCA | WHITE BODY WALL TILES | REVÊTEMENTS EN PÂTE BLANCHE | WEISßSCHERBIGER WANDFLIESEN

	PZ/BOX	MQ/BOX	KG/BOX	BOX/PLT	MQ/PLT	KG/PLT	SPESSORE
30,5x91,5 RT	5	1,395	21,00	42	58,59	894	8,5 mm
30,5x91,5 RT twist	5	1,395	21,00	42	58,59	894	8,5 mm
30,5x91,5 RT struttura MOVE	4	1,116	20,50	42	46,88	831	8,5 mm*
30,5x91,5 RT campitura	2	-	-	-	-	-	-
profilo metallo 0,5x100	3	-	-	-	-	-	8 mm

* Spessore riferito al fondo liscio equivalente . Thickness refers to the equivalent smooth background
Épaisseur se rapportant au carreau lisse équivalent . Die Stärke bezieht sich auf die entsprechende glatte Grundfliese

PAVIMENTI COORDINABILI IN GRES PORCELLANATO | COORDINATE FLOORS TILES PORCELAIN STONWARE

SOL COORDONNÉ EN GRÉS CÈRAME | KOODINIERTER BODENFLIESEN FEINSTEINZEUG

	MET-LIGHT	MET-PEARL	MET-GREY	MET-AVIO	MET-SAGE
YOUR MATCH (pag. 228)					
	CLAY	GREY	DARK	PEARL	MINT
NATURAL APPEAL (pag. 148)					
	NATURAL BLONDE	NATURAL WILD	NATURAL LIGHT	NATURAL ALMOND	NATURAL BLONDE
FREEDHOME (pag. 106)					
	AMBER	TOBACCO	ÉCRU	HONEY	SAND

Natural Appeal



Natural Almond 7,5x60 . 3"x24"

NATURAL APPEAL

GRES PORCELLANATO | PORCELAIN TILE | GRÈS CÉRAME | FEINSTEINZEUG
EN 14411 Allegato G . Piastrelle di ceramica pressate a secco con basso assorbimento d'acqua (E ≤ 0,5%) | Gruppo B la

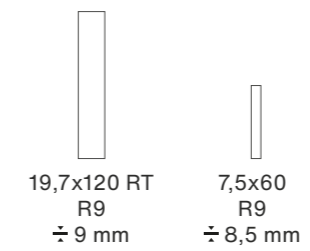

SUPERFICIE NATURALE | NATURAL SURFACE FINISH | SURFACE NATURELLE | NATÜRLICHE OBERFLÄCHE

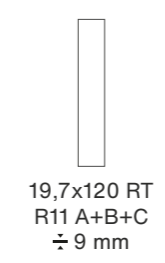

SUPERFICIE STRUTTURATA | STRUCTURED | SURFACE FINISH | FINITION STRUCTURÉE | STRUKTURIERTE OBERFLÄCHE

NATURAL APPEAL



NATURAL APPEAL

GRES PORCELLANATO | PORCELAIN TILE | GRÈS CÉRAMÉ | FEINSTEINZEUG

NATURAL LIGHT



FINITURA NATURALE R9			
NT12	19,7x120 RT - 7 3/4"x48"		± 9 mm
NT6Ø	7,5x60 - 3"x24"		± 8,5 mm

NATURAL ALMOND



FINITURA NATURALE R9			
NL2	19,7x120 RT - 7 3/4"x48"		± 9 mm
NA6Ø	7,5x60 - 3"x24"		± 8,5 mm
FINITURA STRUTTURATA R11 A+B+C			
NTA2	19,7x120 RT - 7 3/4"x48"		± 9 mm

NATURAL BLONDE



FINITURA NATURALE R9			
NTB2	19,7x120 RT - 7 3/4"x48"		± 9 mm
NB6Ø	7,5x60 - 3"x24"		± 8,5 mm
FINITURA STRUTTURATA R11 A+B+C			
NTBS	19,7x120 RT - 7 3/4"x48"		± 9 mm

NATURAL WILD



FINITURA NATURALE R9			
NTW2	19,7x120 RT - 7 3/4"x48"		± 9 mm
FINITURA STRUTTURATA R11 A+B+C			
NTWS	19,7x120 RT - 7 3/4"x48"		± 9 mm

Pezzi speciali

SPECIAL TILES | PIÈCES SPÉCIALES | FORMTEILE

	NATURAL LIGHT	NATURAL ALMOND	NATURAL BLONDE	NATURAL WILD
Battiscopa TD 6x120	NL6B	NA6B	NB6B	NW6B

Imballi

EMBALLAGE | VERPACKUNG | PACKING

NATURAL APPEAL

GRES PORCELLANATO | PORCELAIN TILE | GRÈS CÉRAMÉ | FEINSTEINZEUG

FORMATO	PZ/BOX	MQ/BOX	KG/BOX	BOX/PLT	MQ/PLT	KG/PLT	SPESSORE
19,7x120 RT	6	1,42	29,00	32	45,39	940	9 mm
19,7x120 RT strutturato	6	1,42	29,00	32	45,39	940	9 mm
7,5x60	22	0,99	19,00	60	59,40	1155	8,5 mm
6x120 battiscopa total dek	8	9,60 ml	12,00	45	432 ml	552	-

GRES PORCELLANATO | PORCELAIN TILE | GRÈS CÉRAMÉ | FEINSTEINZEUG

EN 14411 Allegato G . Piastrelle di ceramica pressate a secco con basso assorbimento d'acqua (E ≤ 0,5%)

Gruppo B la

Caratteristiche tecniche Technical characteristics	Norma Norms	Superficie Naturale	Superficie Strutturata
Resistenza all'abrasione profonda Abrasion resistance	ISO 10545-6	≤ 175 mm ³	≤ 175 mm ³
Resistenza allo scivolamento Slip resistance	EN 16165 (previously DIN 51130)	R9	R11
Resistenza allo scivolamento - Superfici bagnate a piedi scalzi Coefficient of friction - Dry surfaces walking on barefoot	EN 16165 (previously DIN 51097)	-	A+B+C
Resistenza allo scivolamento Dynamic coefficient of friction (DCOF)	ANSI A326.3	Conforme According to	Conforme According to
Coefficiente di attrito dinamico Dynamic friction coefficient	METODO B.C.R.A.	Conforme According to	Conforme According to
Grado di variazione cromatica Colour shade variation	V1 min - V4 max	Natural Light V2 Natural Blonde V3 - Natural Wild V3 Natural Almond V3	

AVVERTENZE PER LA POSA - Gres porcellanato

RECOMMENDATIONS FOR INSTALLATION - Porcelain tile

Per la posa del materiale rettificato si prescrive una fuga minima di 2 mm.

As for rectified materials, a minimum joint of 2 mm is required.

Pour la pose du matériau rectifié, il faut réaliser un joint minimum de 2 mm.

Für die Verlegung des geschliffenen Materials ist eine Mindestfuge von 2 mm vorgeschrieben.

Si raccomanda di posare i materiali sfalsati di 20 cm al massimo, mai a metà della loro lunghezza

It is strongly recommended to install the materials in a staggered pattern of a maximum of 20 cm, never at half way its length.

Il est conseillé de poser les matériaux en décalé de 20 cm au maximum, jamais à la moitié de leur longueur.

Es wird empfohlen, die Materialien um höchstens 20 cm versetzt zu verlegen und nie in der Mitte ihrer Länge.

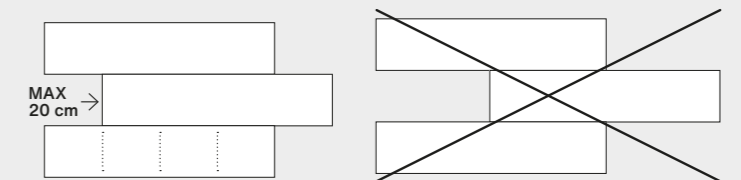

Per maggiori dettagli e aggiornamenti sulle certificazioni, consultare il nostro sito www.supergres.com
 For further details and updated information on certifications, please visit our website www.supergres.com
 Pour obtenir plus d'informations et de mises à jour sur les certifications, veuillez consulter notre site www.supergres.com
 Für weitere Details und Aktualisierungen der Zertifizierungen besuchen Sie bitte unsere Internetseite www.supergres.com

Overtime



Time ivory 120x120 RT - 48"x48"
 Time ivory struttura 60x120 RT - 24"x48"
 Time ivory T20 60x60 RT 24"x24"

OVERTIME / FLOOR

GRES PORCELLANATO | PORCELAIN TILE | GRÈS CÉRAME | FEINSTEINZEUG
 EN 14411 Allegato G . Piastrelle di ceramica pressate a secco con basso assorbimento d'acqua (E ≤ 0,5%) | Gruppo B la

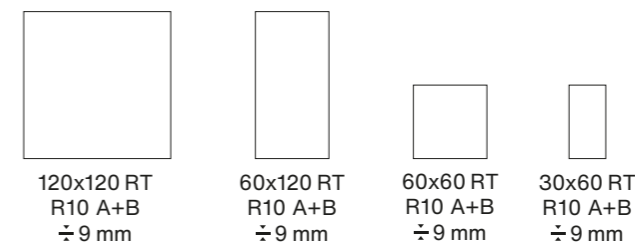

SUPERFICIE ANTI-SLIP SOFT TOUCH | ANTI-SLIP SOFT TOUCH SURFACE
 ANTI-SLIP SOFT TOUCH SURFACE | ANTI-SLIP SOFT TOUCH OBERFLÄCHE

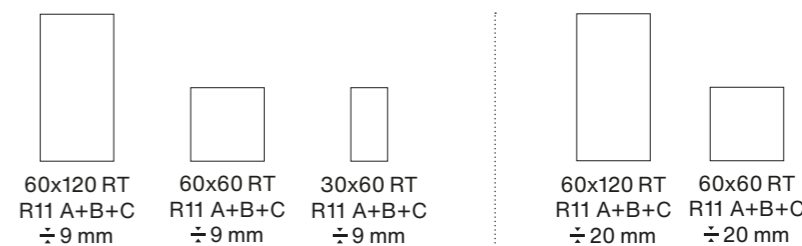

* SUPERFICIE GRIP | SURFACE GRIP | SURFACE GRIP | OBERFLÄCHE GRIP

* **disponibile solo su ordinazione** / available only upon request

T20 Page n. 286

OVERTIME / WALL

RIVESTIMENTO IN PASTA BIANCA | WHITE BODY WALL TILES | REVÊTEMENTS EN PÂTE BLANCHE | WEISBSCHERBIGER WANDFLIESEN
 EN 14411 Allegato L . Piastrelle di ceramica pressate a secco (E >10%) | Gruppo BIII

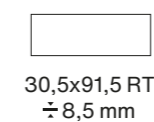

SUPERFICIE SATINATA | SATIN SURFACE FINISH | SURFACE SATINÉE | SATINIERTER OBERFLÄCHE

OVERTIME



Time Taupe 120x120 RT . 48"x48"
Time Taupe grip 60x120 RT . 24"x48"



Time Dark 60x120 RT . 24"x48"

OVERTIME/ FLOOR

GRES PORCELLANATO | PORCELAIN TILE | GRÈS CÉRAMÉ | FEINSTEINZEUG

TIME IVORY



FINITURA ANTI-SLIP SOFT TOUCH R10 A+B		
TMI1	120x120 RT - 48"x48"	± 9 mm
TVR1	60x120 RT - 24"x48"	± 9 mm
IVT6	60x60 RT - 24"x24"	± 9 mm
TIV3	30x60 RT - 12"x24"	± 9 mm
FINITURA GRIP R11 A+B+C **		
TGP1	60x120 RT - 24"x48"	± 9 mm
TIVG	60x60 RT - 24"x24"	± 9 mm
TIGP	30x60 RT - 12"x24"	± 9 mm
FINITURA STRUTTURATA R11 A+B+C * T.20		
TIV1	60x120 RT - 24"x48" T20	± 20 mm
TIV6	60x60 RT - 24"x24" T20	± 20 mm
MOSAICI		
TIMD	mosaico dot 28,3x28,3 - 11"x11"	± 9 mm
TIM3	mosaico 30x30 RT - 12"x12"	± 9 mm



Mosaico Dot

FORMATO TESSERA
MOSAIC SIZE
Ø 3,8 - 1.6"

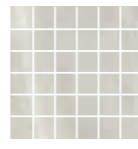

Mosaico

FORMATO TESSERA
MOSAIC SIZE
4,8x4,8 - 2"x 2"

TIME TAUPE



FINITURA ANTI-SLIP SOFT TOUCH R10 A+B		
TMT1	120x120 RT - 48"x48"	± 9 mm
TTP1	60x120 RT - 24"x48"	± 9 mm
TPT6	60x60 RT - 24"x24"	± 9 mm
TTP3	30x60 RT - 12"x24"	± 9 mm
FINITURA GRIP R11 A+B+C **		
TGP2	60x120 RT - 24"x48"	± 9 mm
TTUG	60x60 RT - 24"x24"	± 9 mm
TTGP	30x60 RT - 12"x24"	± 9 mm
MOSAICI		
TTMD	mosaico dot 28,3x28,3 - 11"x11"	± 9 mm
TPM3	mosaico 30x30 RT - 12"x12"	± 9 mm



Mosaico Dot

FORMATO TESSERA
MOSAIC SIZE
Ø 3,8 - 1.6"

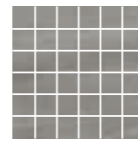

Mosaico

FORMATO TESSERA
MOSAIC SIZE
4,8x4,8 - 2"x 2"

TIME GREY



FINITURA ANTI-SLIP SOFT TOUCH R10 A+B		
TMG1	120x120 RT - 48"x48"	± 9 mm
TMG6	60x120 RT - 24"x48"	± 9 mm
GRT6	60x60 RT - 24"x24"	± 9 mm
TGY3	30x60 RT - 12"x24"	± 9 mm
FINITURA GRIP R11 A+B+C **		
TGGP	60x120 RT - 24"x48"	± 9 mm
TYGP	60x60 RT - 24"x24"	± 9 mm
TGYP	30x60 RT - 12"x24"	± 9 mm
FINITURA STRUTTURATA R11 A+B+C * T.20		
TGR1	60x120 RT - 24"x48" T20	± 20 mm
TGR6	60x60 RT - 24"x24" T20	± 20 mm
MOSAICI		
TGMD	mosaico dot 28,3x28,3 - 11"x11"	± 9 mm
TGMS	mosaico 30x30 RT - 12"x12"	± 9 mm

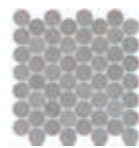

Mosaico Dot

FORMATO TESSERA
MOSAIC SIZE
Ø 3,8 - 1.6"

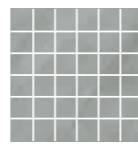

Mosaico

FORMATO TESSERA
MOSAIC SIZE
4,8x4,8 - 2"x 2"

TIME WHITE



FINITURA ANTI-SLIP SOFT TOUCH R10 A+B		
P1CH	120x120 RT - 48"x48"	± 9 mm
TWH1	60x120 RT - 24"x48"	± 9 mm
WHT6	60x60 RT - 24"x24"	± 9 mm
TWH3	30x60 RT - 12"x24"	± 9 mm
FINITURA GRIP R11 A+B+C **		
TWP1	60x120 RT - 24"x48"	± 9 mm
TH6G	60x60 RT - 24"x24"	± 9 mm
TWGP	30x60 RT - 12"x24"	± 9 mm
FINITURA STRUTTURATA R11 A+B+C * T.20		
TWT2	60x120 RT - 24"x48" T20	± 20 mm
THT6	60x60 RT - 24"x24" T20	± 20 mm
MOSAICI		
TWMD	mosaico dot 28,3x28,3 - 11"x11"	± 9 mm
TWMS	mosaico 30x30 RT - 12"x12"	± 9 mm



Mosaico Dot

FORMATO TESSERA
MOSAIC SIZE
Ø 3,8 - 1.6"

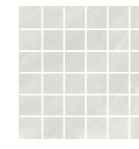

Mosaico

FORMATO TESSERA
MOSAIC SIZE
4,8x4,8 - 2"x 2"

TIME DARK



FINITURA ANTI-SLIP SOFT TOUCH R10 A+B		
P1SC	120x120 RT - 48"x48"	± 9 mm
TDA1	60x120 RT - 24"x48"	± 9 mm
DKT6	60x60 RT - 24"x24"	± 9 mm
TDK3	30x60 RT - 12"x24"	± 9 mm
FINITURA STRUTTURATA R11 A+B+C * T.20		
TDK1	60x120 RT - 24"x48" T20	± 20 mm
TDK6	60x60 RT - 24"x24" T20	± 20 mm
MOSAICI		
TDMD	mosaico dot 28,3x28,3 - 11"x11"	± 9 mm
TDMS	mosaico 30x30 RT - 12"x12"	± 9 mm

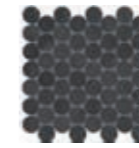

Mosaico Dot

FORMATO TESSERA
MOSAIC SIZE
Ø 3,8 - 1.6"

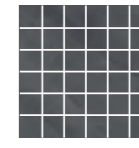

Mosaico

FORMATO TESSERA
MOSAIC SIZE
4,8x4,8 - 2"x 2"

** Finitura Grip su richiesta / Grip finish available only upon request

* Gamma completa Overtime T20 a pagina 286 / For the complete range Overtime T20 go to page 286

OVERTIME / WALL



RIVESTIMENTO
Time moon 30.5x91.5 RT - 12"x36"
Time camp.foliage 30.5x91.5 RT - 12"x36"

PAVIMENTO
Ekho silk 19.7x120RT - 73/4"x48" serie Ekho

OVERTIME / WALL

RIVESTIMENTO IN PASTA BIANCA | WHITE BODY WALL TILES | REVÊTEMENTS EN PÂTE BLANCHE | WEISBSCHERBIGER WANDFLIESEN

TIME MOON



TM09 - 30,5x91,5 RT - 12"x36" - ÷ 8,5 mm

TIME MOON . STRUTTURA WAVE



TMWW - 30,5x91,5 RT - 12"x36" MQ

TIME MOON . STRUT. WAVE | DEK GLITTER



TMGL - 30,5x91,5 RT - 12"x36"

TIME CAMP. LINE



TCLN - 30,5x91,5 RT - 12"x36" - ÷ 8,5 mm

TIME SILK



TSK9 - 30,5x91,5 RT - 12"x36" - ÷ 8,5 mm

TIME SILK . STRUTTURA WAVE



TKWW - 30,5x91,5 RT - 12"x36" MQ

TIME SILK . STRUT. WAVE | DEK GLITTER



TMSG - 30,5x91,5 RT - 12"x36"

TIME CAMP. FOLIAGE



TCF9 - 30,5x91,5 RT - 12"x36" - ÷ 8,5 mm MQ

TIME SILVER

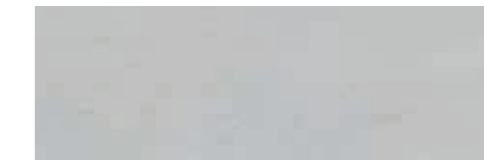

TSV9 - 30,5x91,5 RT - 12"x36" - ÷ 8,5 mm

TIME SILVER . STRUTTURA WAVE



TSWV - 30,5x91,5 RT - 12"x36" MQ

TIME SILVER . STRUT. WAVE | DEK GLITTER



TIWG - 30,5x91,5 RT - 12"x36"

TIME FOLIAGE Mosaico Dot



TFMD - 28,3x28,3 - 11"x11" - ÷ 8,5 mm

FORMATO TESSERA
MOSAIC SIZE
Ø 3,8 - 1,6"

PMGG profilo metallo glitter gold 1x100 RT - 0,4"x40"

PMGI profilo metallo glitter iron 1x100 RT - 0,4"x40"

PMGS profilo metallo glitter silver 1x100 RT - 0,4"x40"

Profili in metallo abbinabili a pag. 251
Metal profiles page 251

PFMC profilo metallo glitter copper 1x100 RT - 0,4"x40"

PAVIMENTI COORDINABILI IN GRES PORCELLANATO | COORDINATE FLOORS TILES PORCELAIN STONEWARE
SOL COORDONNÉ EN GRÉS CÈRAME | KOODINIERTE BODENFLIESEN FEINSTEINZEUG

	TIME MOON	TIME SILK	TIME SILVER	TIME CAMP. FOLIAGE
OVERTIME (pag. 154)				
	TIME WHITE	TIME IVORY	TIME GREY	TIME TAUPE
FREEDHOME (pag. 106)				
	HONEY	AMBER	TOBACCO	ÉCRU
EKHO (pag. 88)				
	EKHO SILK	EKHO NUT	EKHO SILK	EKHO SILK

OVERTIME

GRES PORCELLANATO | PORCELAIN TILE | GRÈS CÉRAMÉ | FEINSTEINZEUG

Pezzi speciali

SPECIAL TILES | PIÈCES SPÉCIALES | FORMTEILE

Pezzi speciali disponibili su tutti i colori, su ordinazione.

Trim tiles available in all colors to order.

Pièces spéciales disponibles dans toutes les couleurs, sur demande.

Formteile auf Bestellung in allen Farben verfügbar.

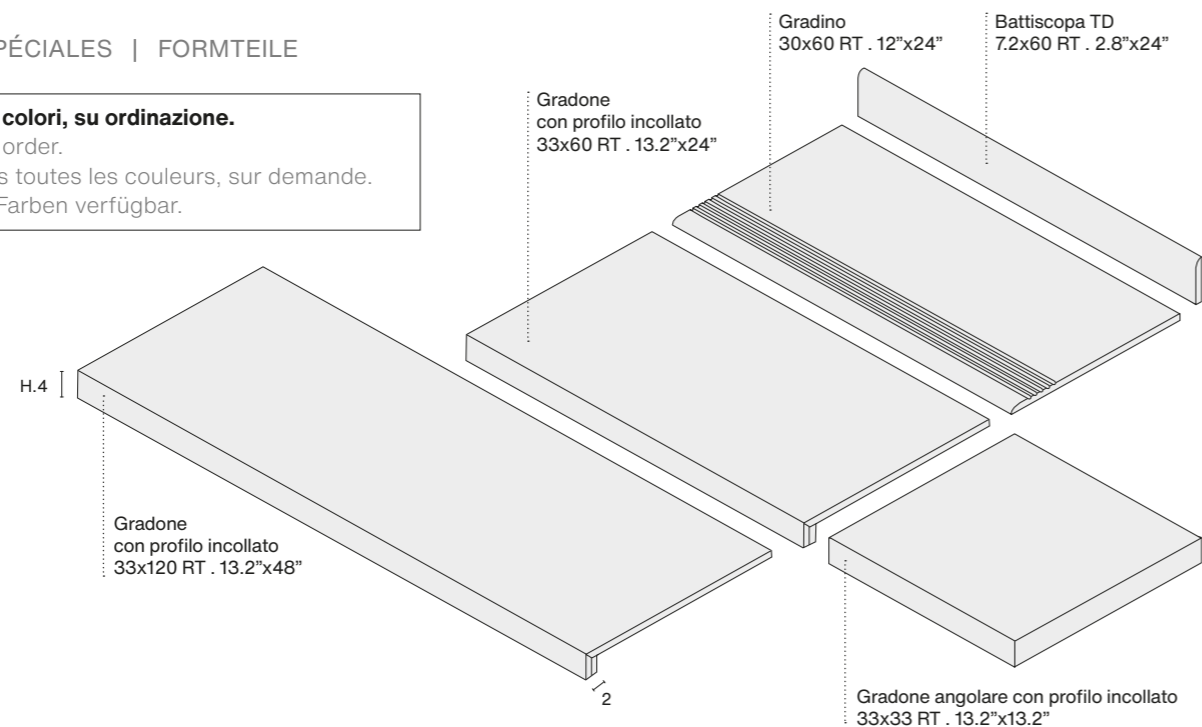

	TIME IVORY	TIME TAUPE	TIME GREY	TIME WHITE	TIME DARK
Gradone c/prof. incollato 33x120 RT	MIG1	TPG1	TGG1	TWG1	TDG1
Gradone c/prof. incollato 33x60 RT	MIG6	TUG6	TYG6	TWG6	TD6G
Ang. Gradone c/prof. inc. 33x33 RT	MIAG	TUAG	MYAG	TWHG	TDAG
Gradino 30x60 RT	IVG6	TPG6	MGG6	WMG6	TKG6
Battiscopa TD 7,2x60	TMIB	TMTB	TMGB	TMWB	TMDB

GRES PORCELLANATO | PORCELAIN TILE | GRÈS CÉRAMÉ | FEINSTEINZEUG

EN 14411 Allegato G . Piastrelle di ceramica pressate a secco con basso assorbimento d'acqua (E ≤ 0,5%)

Gruppo B la

Caratteristiche tecniche Technical characteristics	Norma Norms	Superficie Anti-Slip Soft Touch	Superficie Grip
Resistenza all'abrasione profonda Abrasion resistance	ISO 10545-6	≤ 175 mm ³	≤ 175 mm ³
Resistenza allo scivolamento Slip resistance	EN 16165 (previously DIN 51130)	R10	R11
Resistenza allo scivolamento - Superfici bagnate a piedi scalzi Coefficient of friction - Dry surfaces walking on barefoot	EN 16165 (previously DIN 51097)	A+B	A+B+C
Resistenza allo scivolamento Dynamic coefficient of friction (DCOF)	ANSI A326.3	Conforme According to	Conforme According to
Coefficiente di attrito dinamico Dynamic friction coefficient	METODO B.C.R.A.	Conforme According to	Conforme According to
Grado di variazione cromatica Colour shade variation	V1 min - V4 max	V2	

Imballi

EMBALLAGE | VERPACKUNG | PACKING

OVERTIME / FLOOR

GRES PORCELLANATO | PORCELAIN TILE | GRÈS CÉRAMÉ | FEINSTEINZEUG

	PZ/BOX	MQ/BOX	KG/BOX	BOX/PLT	MQ/PLT	KG/PLT	SPESSORE
120x120 RT	2	2,88	60,00	20	57,60	1212	9 mm
60x120 RT	2	1,44	30,00	35	50,40	1062	9 mm
60x60 RT	3	1,08	22,00	40	43,20	892	9 mm
30x60 RT	7	1,26	25,00	40	50,40	1012	9 mm
60x120 RT grip	2	1,44	30,00	35	50,40	1062	9 mm
60x60 RT grip	3	1,08	22,00	40	43,20	892	9 mm
30x60 RT grip	7	1,26	25,00	40	50,40	1012	9 mm
30x30 RT mosaico	10	0,90	16,00	30	27,00	495	9 mm
28,3x28,3 RT mosaico dot su rete	6	0,48	9,50	48	23,04	468	9 mm
33x120 RT gradone c/prof.incollato	2	-	-	-	-	-	-
33x60 RT gradone c/prof incollato	4	-	-	-	-	-	-
33x33 RT ang.gradone c/prof.inc.	4	-	-	-	-	-	-
30x60 RT gradino	7	-	-	-	-	-	-
7,2x60 battiscopa total dek	10	6,00 ml	9,40	70	420 ml	673	-

OVERTIME / WALL

RIVESTIMENTO IN PASTA BIANCA | WHITE BODY WALL TILES | REVÊTEMENTS EN PÂTE BLANCHE | WEISßSCHERBIGER WANDFLIESEN

	PZ/BOX	MQ/BOX	KG/BOX	BOX/PLT	MQ/PLT	KG/PLT	SPESSORE
30,5x91,5 RT	5	1,395	21,00	42	58,59	894	8,5 mm
30,5x91,5 RT struttura	4	1,120	20,35	42	46,87	873	8,5 mm*
30,5x91,5 RT campitura foliage	5	1,395	21,00	42	58,59	894	8,5 mm
30,5x91,5 RT campitura	2	-	-	-	-	-	-
30,5x91,5 RT struttura dek	2	-	-	-	-	-	-
28.3x28.3 mosaico dot foliage	6	0,48	8,40	48	23,04	415	-
profilo 1x100	3	-	-	-	-	-	8 mm

* Spessore riferito al fondo liscio equivalente . Thickness refers to the equivalent smooth background
Épaisseur se rapportant au carreau lisse équivalent . Die Stärke bezieht sich auf die entsprechende glatte Grundfliese

AVVERTENZE PER LA POSA - Gres porcellanato

RECOMMENDATIONS FOR INSTALLATION - Porcelain tile

Per la posa del materiale rettificato si prescrive una fuga minima di 2 mm.

As for rectified materials, a minimum joint of 2 mm is required.

Pour la pose du matériau rectifié, il faut réaliser un joint minimum de 2 mm.

Für die Verlegung des geschliffenen Materials ist eine Mindestfuge von 2 mm vorgeschrieben.

Si raccomanda di posare i materiali sfalsati di 20 cm al massimo, mai a metà della loro lunghezza

It is strongly recommended to install the materials in a staggered pattern of a maximum of 20 cm, never at half way its length.

Il est conseillé de poser les matériaux en décalé de 20 cm au maximum, jamais à la moitié de leur longueur.

Es wird empfohlen, die Materialien um höchstens 20 cm versetzt zu verlegen und nie in der Mitte ihrer Länge.

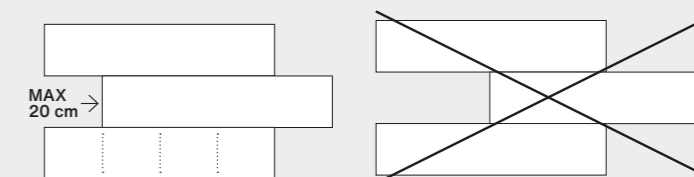

Per maggiori dettagli e aggiornamenti sulle certificazioni, consultare il nostro sito www.supergres.com
For further details and updated information on certifications, please visit our website www.supergres.com
Pour obtenir plus d'informations et de mises à jour sur les certifications, veuillez consulter notre site www.supergres.com
Für weitere Details und Aktualisierungen der Zertifizierungen besuchen Sie bitte unsere Internetseite www.supergres.com

Purity of Marble



Pavimento
Elegant greige lux 75x150RT - 30"x60"

Rivestimento
Pure white lux 120x278RT - 48"x109 1/2"

PURITY OF MARBLE / FLOOR

GRES PORCELLANATO | PORCELAIN TILE | GRÈS CÉRAME | FEINSTEINZEUG
EN 14411 Allegato G . Piastrelle di ceramica pressate a secco con basso assorbimento d'acqua (E ≤ 0,5%) | Gruppo B la

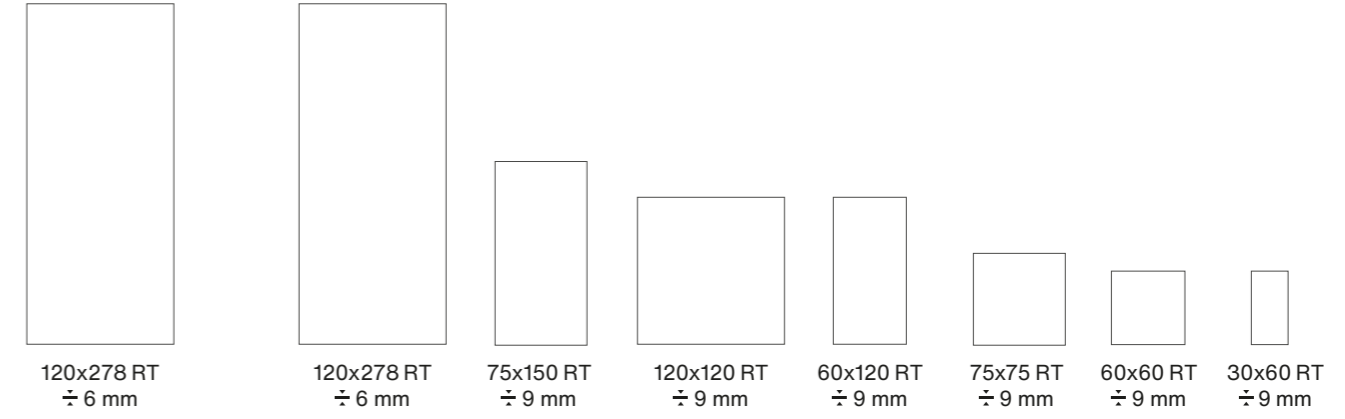

SUPERFICIE SILK
SILK SURFACE FINISH
FINITION SILK
OBERFLÄCHE SILK

SUPERFICIE LUX | LUX SURFACE FINISH | FINITION LUX | OBERFLÄCHE LUX



60x120 RT
÷ 9 mm

SUPERFICIE NATURALE | NATURAL SURFACE FINISH | SURFACE NATURELLE | NATÜRLICHE OBERFLÄCHE

PURITY OF MARBLE / WALL

RIVESTIMENTO IN PASTA BIANCA | WHITE BODY WALL TILES | REVÊTEMENTS EN PÂTE BLANCHE | WEISBSCHERBIGER WANDFLIESEN
EN 14411 Allegato L . Piastrelle di ceramica pressate a secco (E >10%) | Gruppo BIII

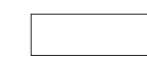
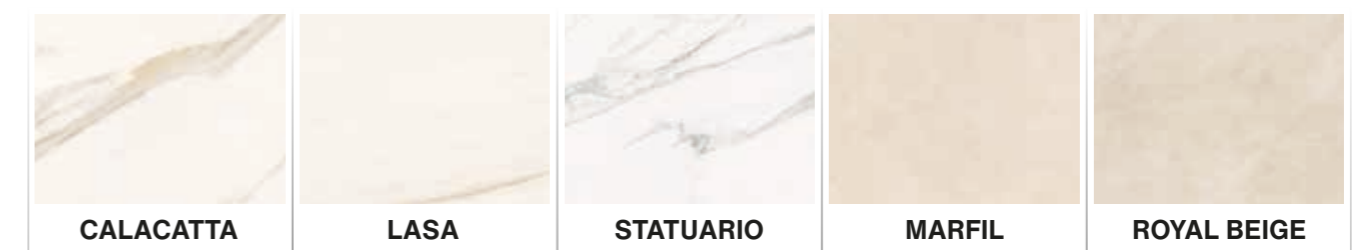

30,5x91,5 RT
÷ 8,5 mm

SUPERFICIE LUCIDA | GLOSSY SURFACE FINISH | SURFACE BRILLANTE | GLÄNZENDE OBERFLÄCHE

PURITY OF MARBLE / FLOOR

GRES PORCELLANATO | PORCELAIN TILE | GRÈS CÉRAMÉ | FEINSTEINZEUG

CALACATTA

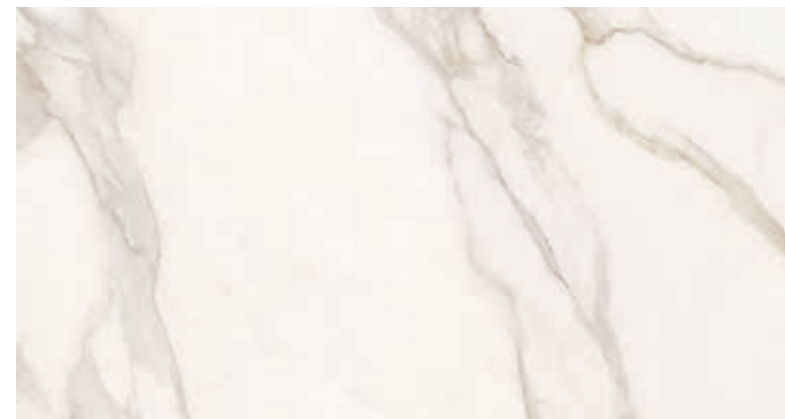

FINITURA LUX		
C278	120x278 RT - 48"x109 ^{1/2} "	± 6 mm
12CX	120x120 RT - 48"x48"	± 9 mm
PCCL	75x150 RT - 30"x60"	± 9 mm
75CX	75x75 RT - 30"x30"	± 9 mm
YPXC	60x120 RT - 24"x48"	± 9 mm
* 6ØCX	60x60 RT - 24"x24"	± 9 mm
* OTPC	60x60 RT ottagonale - 24"x24"	± 9 mm
* 3PCX	30x60 RT - 12"x24"	± 9 mm
FINITURA NATURALE R9		
PTC6	60x120 RT - 24"x48"	± 9 mm

STATUARIO



FINITURA LUX		
S278	120x278 RT - 48"x109 ^{1/2} "	± 6 mm
12SX	120x120 RT - 48"x48"	± 9 mm
STX5	75x150 RT - 30"x60"	± 9 mm
75SX	75x75 RT - 30"x30"	± 9 mm
YPSX	60x120 RT - 24"x48"	± 9 mm
* 6ØSX	60x60 RT - 24"x24"	± 9 mm
* OTPS	60x60 RT ottagonale - 24"x24"	± 9 mm
* 3PSX	30x60 RT - 12"x24"	± 9 mm
FINITURA SILK		
STSK	120x278 RT - 48"x109 ^{1/2} "	± 6 mm
FINITURA NATURALE R9		
PST6	60x120 RT - 24"x48"	± 9 mm

ELEGANT GREIGE

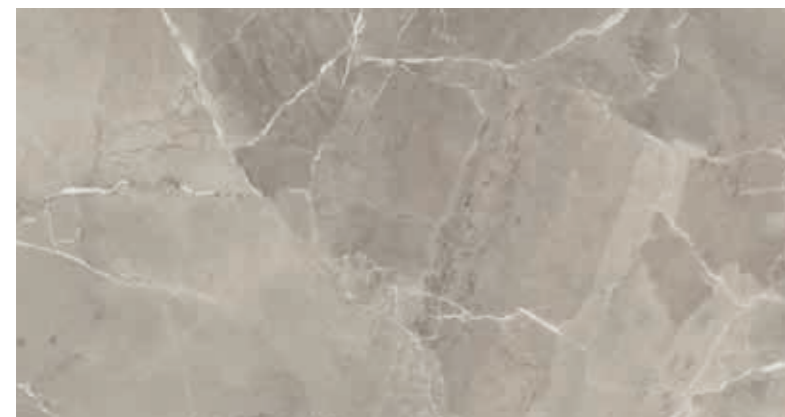

FINITURA LUX		
PES8	120x278 RT - 48"x109 ^{1/2} "	± 6 mm
EX12	120x120 RT - 48"x48"	± 9 mm
PGX5	75x150 RT - 30"x60"	± 9 mm
75EG	75x75 RT - 30"x30"	± 9 mm
YELG	60x120 RT - 24"x48"	± 9 mm
* 6ØEG	60x60 RT - 24"x24"	± 9 mm
* OEGX	60x60 RT ottagonale - 24"x24"	± 9 mm
* 3PEG	30x60 RT - 12"x24"	± 9 mm
FINITURA SILK		
EGSK	120x278 RT - 48"x109 ^{1/2} "	± 6 mm
FINITURA NATURALE R9		
PEL6	60x120 RT - 24"x48"	± 9 mm

SUPREME DARK

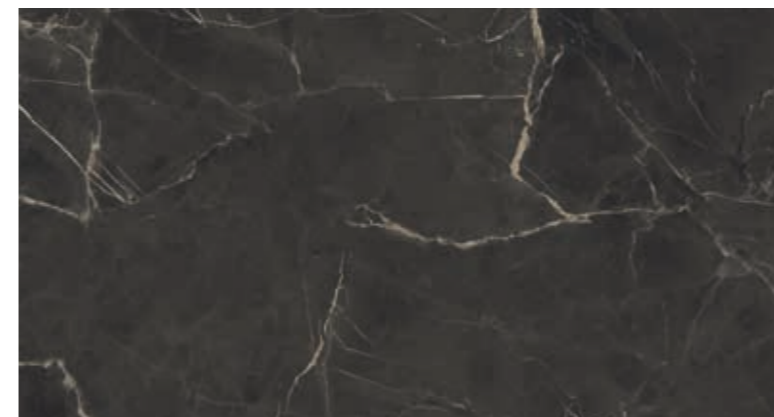

FINITURA LUX		
PSD8	120x278 RT - 48"x109 ^{1/2} "	± 6 mm
PSD1	120x120 RT - 48"x48"	± 9 mm
PUXD	75x150 RT - 30"x60"	± 9 mm
75SD	75x75 RT - 30"x30"	± 9 mm
YSDK	60x120 RT - 24"x48"	± 9 mm
FINITURA NATURALE R9		
PSD6	60x120 RT - 24"x48"	± 9 mm

PURE WHITE

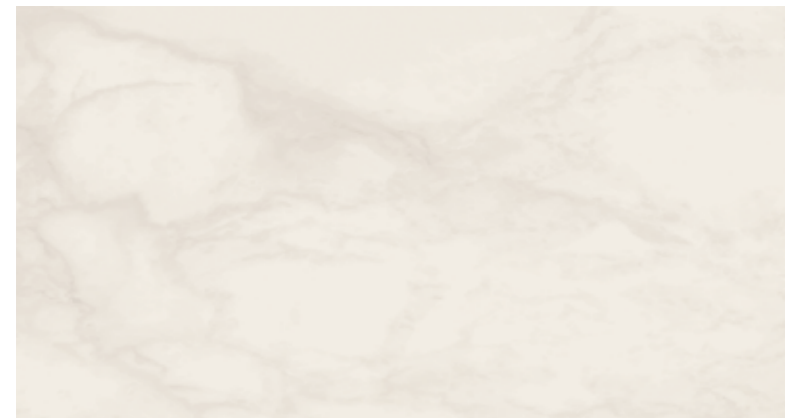

FINITURA LUX		
W278	120x278 RT - 48"x109 ^{1/2} "	± 6 mm
WX12	120x120 RT - 48"x48"	± 9 mm
PUX5	75x150 RT - 30"x60"	± 9 mm
HX75	75x75 RT - 30"x30"	± 9 mm
YPPW	60x120 RT - 24"x48"	± 9 mm
* HX6Ø	60x60 RT - 24"x24"	± 9 mm
* PW06	60x60 RT ottagonale - 24"x24"	± 9 mm
* HP3Ø	30x60 RT - 12"x24"	± 9 mm
FINITURA SILK		
PWSK	120x278 RT - 48"x109 ^{1/2} "	± 6 mm
FINITURA NATURALE R9		
PCT6	60x120 RT - 24"x48"	± 9 mm

ONYX PEARL

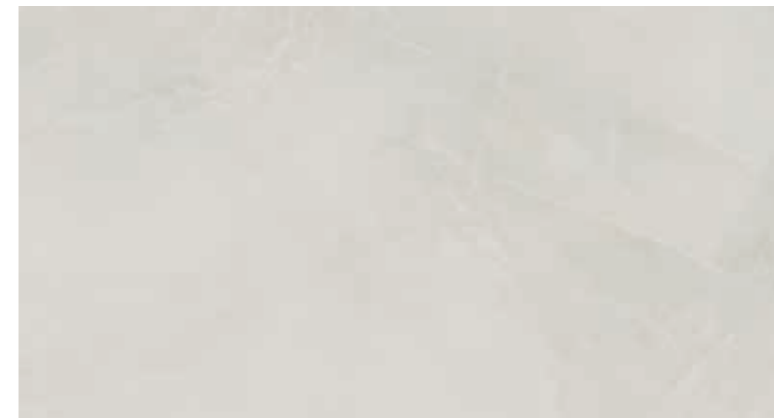

FINITURA LUX		
OX12	120x120 RT - 48"x48"	± 9 mm
OYX5	75x150 RT - 30"x60"	± 9 mm
OX75	75x75 RT - 30"x30"	± 9 mm
ON6X	60x120 RT - 24"x48"	± 9 mm
FINITURA NATURALE R9		
POX6	60x120 RT - 24"x48"	± 9 mm

* disponibili solo su ordinazione . available only upon request

PURITY OF MARBLE / FLOOR

GRES PORCELLANATO | PORCELAIN TILE | GRÈS CÉRAMÉ | FEINSTEINZEUG

MARFIL

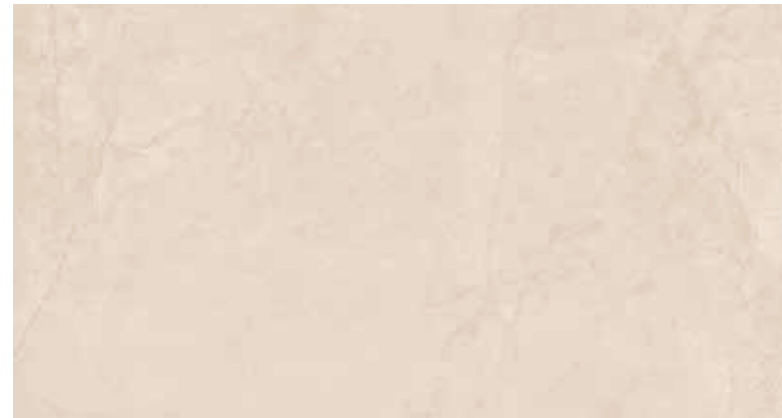

FINITURA LUX		
M278	120x278 RT - 48"x109 1/2"	± 6 mm
12MX	120x120 RT - 48"x48"	± 9 mm
PMF5	75x150 RT - 30"x60"	± 9 mm
75MX	75x75 RT - 30"x30"	± 9 mm
MR6X	60x120 RT - 24"x48"	± 9 mm
* 6ØMX	60x60 RT - 24"x24"	± 9 mm
* OTMX	60x60 RT ottagona - 24"x24"	± 9 mm
* 3PMX	30x60 RT - 12"x24"	± 9 mm
FINITURA NATURALE R9		
MF6P	60x120 RT - 24"x48"	± 9 mm

LASA



FINITURA LUX		
12LX	120x120 RT - 48"x48"	± 9 mm
ULX5	75x150 RT - 30"x60"	± 9 mm
75LX	75x75 RT - 30"x30"	± 9 mm
LS6X	60x120 RT - 24"x48"	± 9 mm
FINITURA NATURALE R9		
PLS6	60x120 RT - 24"x48"	± 9 mm

ROYAL BEIGE



FINITURA LUX		
12RX	120x120 RT - 48"x48"	± 9 mm
RYB5	75x150 RT - 30"x60"	± 9 mm
75RX	75x75 RT - 30"x30"	± 9 mm
RY6X	60x120 RT - 24"x48"	± 9 mm
* 6ØRX	60x60 RT - 24"x24"	± 9 mm
* OTRX	60x60 RT ottagona - 24"x24"	± 9 mm
* 3PRX	30x60 RT - 12"x24"	± 9 mm
FINITURA NATURALE R9		
RYB6	60x120 RT - 24"x48"	± 9 mm

* disponibili solo su ordinazione . available only upon request

Pezzi speciali

SPECIAL TILES | PIÈCES SPÉCIALES | FORMTEILE

Pezzi speciali disponibili su tutti i colori, su ordinazione.





Trim tiles available in all colors to order.

Pièces spéciales disponibles dans toutes les couleurs, sur demande.

Formteile auf Bestellung in allen Farben verfügbar.

	CALACATTA	ELEGANT GREIGE	SUPREME DARK	PURE WHITE	STATUARIO	ONYX PEARL	MARFIL	LASA	ROYAL BEIGE
GRADONE C/PROF INCOLLATO 33x120 RT LUX	PCG1	PELG	PSDG	PW1G	GS12	POG1	PRBG	GL12	PRYG
GRADONE C/PROF INCOLLATO 33x60 RT LUX	GC60	PEG6	-	WGR6	GS60	-	PM6G	-	PRY6
ANG. GRADONE C/PROF.INC. 33x33 RT LUX	CXGS	SXEG	SXSD	PWAS	SXGS	PYAS	MXSX	LXSG	PRSX
GRADINO 30x60 RT LUX	XCG7	PE6G	-	PPW7	SGG7	-	MXG7	-	RBG7
BATTISCOPA TD 7,2x75 LUX	BCX7	PE7B	PS7B	PUB7	BSX7	BOX7	PXM7	BLX7	PRB7
BATTISCOPA TD 7,2x60 LUX	BCX6	PEB6	SDXB	PWXB	BSX6	OBX6	PMX7	BLX6	PRX6
GRADONE C/PROF INCOLLATO 33x120 RT	PCL2	PEG2	PSD2	PPH2	PSG2	POP2	PMF2	PLS2	PRB2
ANG. GRADONE C/PROF. INC. 33x33 RT	LC33	EGDX	PSDA	PPWA	SP33	PPOD	PMA3	LG33	PRBD
BATTISCOPA TD 7,2x60	BCB6	PELB	PSDB	PWT6	BSB6	OYB6	PMB6	BLB6	PRB6

TOZZETTI IN MARMO | PIÈCES SPÉCIALES EN MARBRE | FORMTEILE AUS MARMOR | MARBLE TRIMS

TOZZETTI MARMO		
	TOZZETTO MARMO TRAVERTINO NOCE	TMTN travertino noce 6x6 - 2,3"x2,3" ± 7,5 mm
	TOZZETTO MARMO EMPERADOR	TMEP emperador 6x6 - 2,3"x2,3" ± 7,5 mm
	TOZZETTO MARMO NERO MARQUINIA	TMNM nero marquinia 6x6 - 2,3"x2,3" ± 7,5 mm
	TOZZETTO MARMO ROSSO VERONA	TMBA bardiglio 6x6 - 2,3"x2,3" ± 7,5 mm
	TOZZETTO MARMO BARDIGLIO	TMRV rosso verona 6x6 - 2,3"x2,3" ± 7,5 mm

La finitura superficiale "LUX" è una nuova tecnica di lappatura di ceramiche Supergres, caratterizzata da una superficie a lappatura integrale che esalta i dettagli della grafica. Le piccole picchiettature, le discontinuità e le leggere ondulazioni della superficie del prodotto sono volute per riprodurre fedelmente l'aspetto reale delle pietre e dei marmi antichi levigati donando al prodotto un aspetto ancora più naturale.

La finitura LUX è consigliata per l'utilizzo a pavimento negli ambienti residenziali e negli ambienti dove non siano richieste delle particolari prestazioni antiscivolo. Per le sue caratteristiche, la finitura LUX è raccomandata solo in ambienti interni e non a diretto contatto con l'esterno, in modo da preservare la brillantezza della superficie.

The "LUX" surface finish is a new honing technique by Ceramiche Supergres that sets itself apart thanks to an integral honing on the surface that exalts the graphic details. The light speckles, the random effect and slight waves on the surface of the product are intentional and created to faithfully reproduce the aspect of age-old polished stones and marble, giving the product an even more natural look. The LUX surface finish is recommended for floor application in residential venues and in locations where special anti-slip performance is not required. Due to these features, in order to maintain the brilliance of the LUX surface finish, it is only suitable for indoor use and not for use in direct contact with outdoor areas.

Avvertenze per la posa lastre 120x278RT a pag. 335.

Raccomandation for installation slabs 120x278 RT on page 335.

Recommandations pour la pose des plaques 120x278 à la page 335.

Hinweise zum Verlegen 120x278 RT auf Seite 335.

PURITY OF MARBLE / WALL

RIVESTIMENTO
Statuario 30,5x91,5 RT - 12"x36"
Statuario struttura fluid 30,5x91,5 RT - 12"x36"

PAVIMENTO
Statuario lux 75x75 RT - 30"x30"



PURITY OF MARBLE / WALL

RIVESTIMENTO IN PASTA BIANCA | WHITE BODY WALL TILES | REVÊTEMENTS EN PÂTE BLANCHE | WEISßSCHERBIGER WANDFLIESEN

STATUARIO



PS9W - 30,5x91,5 RT - 12"x36" - ± 8,5 mm

STATUARIO . STRUTTURA FLUID



PSSF - 30,5x91,5 RT - 12"x36" MQ

STATUARIO . CAMPITURA RAMAGE



PSCR - 30,5x91,5 RT - 12"x36" - ± 8,5 mm

STATUARIO . BRICK



PLS3 - 30,5x30,5 RT - 12"x12" - ± 8,5 mm

ULPS pu. spigolo ice
0,8x30,5 - 0,3"x12"

ULAS ang/est
h 0,8 - 0,3"

LASA



PLW9 - 30,5x91,5 RT - 12"x36"

LASA . STRUTTURA FLUID



PLSF - 30,5x91,5 RT - 12"x36" MQ

LASA . CAMPITURA RAMAGE

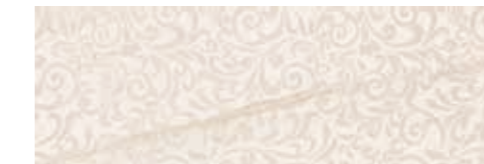

PLCR - 30,5x91,5 RT - 12"x36" - ± 8,5 mm

LASA . BRICK



PLB3 - 30,5x30,5 RT - 12"x12" - ± 8,5 mm

UKSP pu. spigolo milk
0,8x30,5 - 0,3"x12"

UKAS ang/est
h 0,8 - 0,3"

MARFIL



PMW9 - 30,5x91,5 RT - 12"x36"

MARFIL . STRUTTURA FLUID



PMS9 - 30,5x91,5 RT - 12"x36" MQ

MARFIL . CAMPITURA RAMAGE

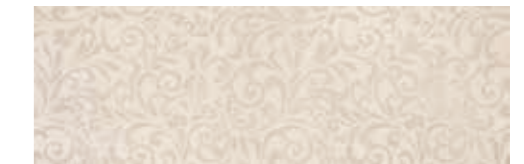

PMCR - 30,5x91,5 RT - 12"x36"

MARFIL . BRICK



PMBR - 30,5x30,5 RT - 12"x12" - ± 8,5 mm

PSHO pu. spigolo honey
0,8x30,5 - 0,3"x12"

PSHA ang/est
h 0,8 - 0,3"

PMAR profilo metallo argento 0,5x100 RT - 0,2"x40"

PMOR profilo metallo oro 0,5x100 RT - 0,2"x40"

PMRA profilo metallo rame 0,5x100 RT - 0,2"x40"

Profili in metallo abbinabili a pag. 251 . metal profiles page 251

PURITY OF MARBLE / WALL



RIVESTIMENTO
Royal Beige 30,5x91,5 RT - 12"x36"
Royal Beige struttura fluid 30,5x91,5 RT - 12"x36"

PAVIMENTO
Calacatta lux 75x75 RT - 30"x30"

PURITY OF MARBLE / WALL

RIVESTIMENTO IN PASTA BIANCA | WHITE BODY WALL TILES | REVÊTEMENTS EN PÂTE BLANCHE | WEISBSCHERBIGER WANDFLIESEN

ROYAL BEIGE



PRW9 - 30,5x91,5 RT - 12"x36" - ± 8,5 mm

ROYAL BEIGE . STRUTTURA FLUID



PRS9 - 30,5x91,5 RT - 12"x36" MQ

ROYAL BEIGE . CAMPITURA RAMAGE



PRYR - 30,5x91,5 RT - 12"x36" - ± 8,5 mm

ROYAL BEIGE . BRICK



PRYB - 30,5x30,5 RT - 12"x12" - ± 8,5 mm

PSHO pu. spigolo honey
0,8x30,5 - 0,3"x12"

PSHA ang/est
h 0,8 - 0,3"

CALACATTA



PCW9 - 30,5x91,5 RT - 12"x36"

CALACATTA . STRUTTURA FLUID



PCSF - 30,5x91,5 RT - 12"x36" MQ

CALACATTA . CAMPITURA RAMAGE

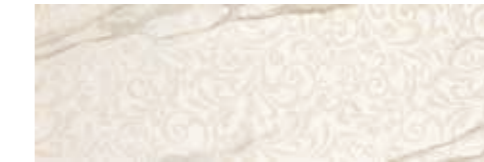

PCCR - 30,5x91,5 RT - 12"x36" - ± 8,5 mm

CALACATTA . BRICK



PLC3 - 30,5x30,5 RT - 12"x12" - ± 8,5 mm

UKSP pu. spigolo milk
0,8x30,5 - 0,3"x12"

UKAS ang/est
h 0,8 - 0,3"

PAVIMENTI COORDINABILI IN GRES PORCELLANATO | COORDINATE FLOORS TILES PORCELAIN STONEWARE
SOL COORDONNÉ EN GRÉS CÈRAME | KOODINIERTE BODENFLIESEN FEINSTEINZEUG

	STATUARIO	LASA	ROYAL BEIGE	CALACATTA	MARFIL
PURITY OF MARBLE (pag. 164)					
	STATUARIO	LASA	ROYAL BEIGE	CALACATTA	MARFIL
COLOVERS (pag. 74)					
	LOVE GREY	LOVE SAND	LOVE BROWN	LOVE WHITE	LOVE BRONZE
NATURAL APPEAL (pag. 148)					
	NATURAL LIGHT	NATURAL WILD	NATURAL ALMOND	NATURAL BLONDE	NATURAL BLONDE

PURITY of MARBLE

GRES PORCELLANATO | PORCELAIN TILE | GRÈS CÉRAMÉ | FEINSTEINZEUG

Imballi

EMBALLAGE | VERPACKUNG | PACKING

PURITY of MARBLE / FLOOR

GRES PORCELLANATO | PORCELAIN TILE | GRÈS CÉRAMÉ | FEINSTEINZEUG

FORMATO	PZ	MQ/PZ	KG/PZ	PZ/CASSA*	MQ/CASSA*	KG/CASSA*	SPESSORE
120x278 RT LUX / SILK	1	3,34	49,50	18	60,05	979	6 mm
120x278 RT	1	3,34	49,50	5	16,68	301	6 mm

 * 120x278 fornito in casse di dimensioni 291,6x144,5x33,8 (PxLxH) cm - Peso kg 88 / o in casse per max 5 pz dim.291.6x144.5x24h - peso kg 52.5
* 120x278 supplied in crates. Dimensions crate cm 291,6x144,5x33,8h cm - Weight kg 88 / crates 5 pcs (charge max). Dim.291.6x144.5x24h - Weight kg 52.5

	PZ	MQ/PZ	KG/PZ	PZ/CAV.**	MQ/CAV. **	KG/CAV.**	SPESSORE
120x278 RT LUX / SILK	1	3,34	49,50	18	60,05	1051	6 mm
120x278 RT LUX / SILK	1	3,34	49,50	42	48,11	2239	6 mm

 ** 120x278 fornito su cavalletti (18 pz o 42 pz - carico max) di dimensioni 290x75x156 (PxLxH) cm - Peso kg 160
** 120x278 supplied in stand containing (18 pcs or 42 pcs - charge max). Dimensions cm 290x75x156h cm - Weight kg 160

	PZ/BOX	MQ/BOX	KG/BOX	BOX/PLT	MQ/PLT	KG/PLT	SPESSORE
120x120 RT LUX	2	2,88	60,00	20	57,60	1212	9 mm
60x120 RT LUX / NAT	2	1,44	30,00	35	50,40	1062	9 mm
75x150 RT LUX	2	2,25	46,00	18	40,50	843	9 mm
75x75 RT LUX	2	1,125	24,00	42	47,25	1020	9 mm
60x60 RT LUX *	3	1,08	22,50	40	43,20	912	9 mm
30x60 RT LUX *	7	1,26	25,00	40	50,40	1012	9 mm
ottagona 60x60 RT LUX *	3	1,069	21,30	40	42,76	867	9 mm
6x6 tozzetto marmo	4	-	-	-	-	-	7,5 mm
7,2x60 battiscopa LUX / NAT	10	6,00 ml	9,00	70	420 ml	645	-
7,2x75 battiscopa LUX	10	7,50 ml	11,00	63	472,50 ml	705	-
33x150 RT gradone c/pr. inc.	2	-	-	-	-	-	-
33x120 RT gradone c/pr. inc.	2	-	-	-	-	-	-
33x75 RT gradone c/profilo incollato	2	-	-	-	-	-	-
33x60 RT gradone c/profilo incollato	4	-	-	-	-	-	-
33x33 RT ang/gradone c/pr.inc.	4	-	-	-	-	-	-
30x60 RT gradino	7	-	-	-	-	-	-

* **disponibile solo su ordinazione** / available only upon request

GRES PORCELLANATO | PORCELAIN TILE | GRÈS CÉRAMÉ | FEINSTEINZEUG

EN 14411 Allegato G . Piastrelle di ceramica pressate a secco con basso assorbimento d'acqua (E ≤ 0,5%)**Gruppo B Ia**

Caratteristiche tecniche Technical characteristics	Norma Norms	Superficie Naturale	Superficie Lux (GL)	Superficie Silk
Resistenza all'abrasione profonda Abrasion resistance	ISO 10545-6	≤ 175 mm ³	-	≤ 175 mm ³
Determinazione della resistenza all'abrasione superficiale (PEI) Surface abrasion resistance (PEI)		-	Risultati delle prove disponibili in azienda Test details can be obtained from the company	-
Resistenza allo scivolamento Slip resistance	EN 16165 (previously DIN 51130)	R9	-	-
Resistenza allo scivolamento Dynamic coefficient of friction (DCOF)	ANSI A326.3	Conforme According to	-	-
Grado di variazione cromatica Colour shade variation	V1 min - V4 max		V2	

Imballi

EMBALLAGE | VERPACKUNG | PACKING

PURITY of MARBLE / WALL

RIVESTIMENTO IN PASTA BIANCA | WHITE BODY WALL TILES | REVÊTEMENTS EN PÂTE BLANCHE | WEISßSCHERBIGER WANDFLIESEN

	PZ/BOX	MQ/BOX	KG/BOX	BOX/PLT	MQ/PLT	KG/PLT	SPESSORE
30,5x91,5 RT	5	1,395	21,00	42	58,59	894	8,5 mm
30,5x91,5 RT struttura FLUID	4	1,12	20,50	42	46,88	873	8,5 mm*
30,5x91,5 RT campitura	2	-	-	-	-	-	-
30,5x30,5 RT brick su rete	6	0,56	7,80	42	23,44	340	-
0,8x30,5 spigolo	6						
ang/est spigolo h. 08	4						
profilo metallo 0,5x100	3	-	-	-	-	-	8 mm

* **Spessore riferito al fondo liscio equivalente** . Thickness refers to the equivalent smooth background
Épaisseur se rapportant au carreau lisse équivalent . Die Stärke bezieht sich auf die entsprechende glatte Grundfliese

AVVERTENZE PER LA POSA - Gres porcellanato RECOMMENDATIONS FOR INSTALLATION - Porcelain tile

Per la posa del materiale rettificato si prescrive una fuga minima di 2 mm.

As for rectified materials, a minimum joint of 2 mm is required.

Pour la pose du matériau rectifié, il faut réaliser un joint minimum de 2 mm.

Für die Verlegung des geschliffenen Materials ist eine Mindestfuge von 2 mm vorgeschrieben.

Si raccomanda di posare i materiali sfalsati di 20 cm al massimo, mai a metà della loro lunghezza

It is strongly recommended to install the materials in a staggered pattern of a maximum of 20 cm, never at half way its length.

Il est conseillé de poser les matériaux en décalé de 20 cm au maximum, jamais à la moitié de leur longueur.

Es wird empfohlen, die Materialien um höchstens 20 cm versetzt zu verlegen und nie in der Mitte ihrer Länge.

Avvertenze per la posa lastre 120x278RT a pag. 335

Raccomandation for installation slabs 120x278 RT on page 335

Recommandations pour la pose des plaques 120x278 à la page 335

Hinweise zum Verlegen 120x278 RT auf Seite 335.

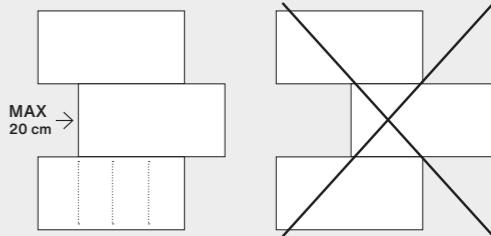
Per maggiori dettagli e aggiornamenti sulle certificazioni, consultare il nostro sito www.supergres.comFor further details and updated information on certifications, please visit our website www.supergres.comPour obtenir plus d'informations et de mises à jour sur les certifications, veuillez consulter notre site www.supergres.comFür weitere Details und Aktualisierungen der Zertifizierungen besuchen Sie bitte unsere Internetseite www.supergres.com

Purity of Marble BRECCIE



Breccia Nera Lux 120x120 RT . 48"x48"

PURITY OF MARBLE BRECCIE

GRES PORCELLANATO | PORCELAIN TILE | GRÈS CÉRAMÉ | FEINSTEINZEUG
EN 14411 Allegato G . Piastrelle di ceramica pressate a secco con basso assorbimento d'acqua (E ≤ 0,5%) | Gruppo B la

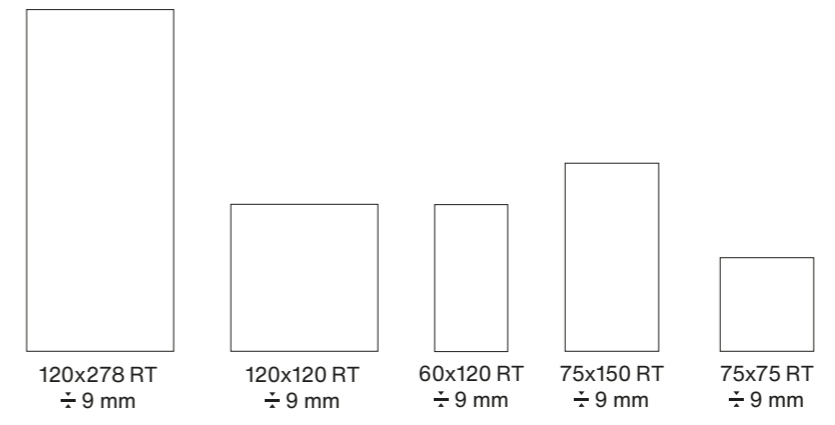
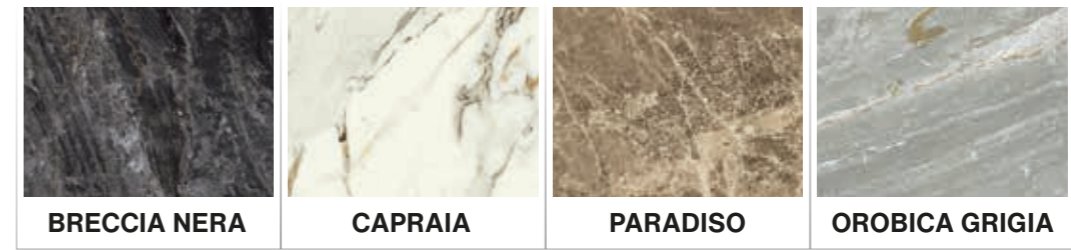

SUPERFICIE LUX | LUX SURFACE FINISH | FINITION LUX | OBERFLÄCHE LUX

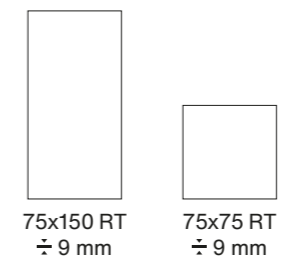

SUPERFICIE NATURALE | NATURAL SURFACE FINISH | SURFACE NATURELLE | NATÜRLICHE OBERFLÄCHE

PURITY OF MARBLE BRECCE

GRES PORCELLANATO | PORCELAIN TILE | GRÈS CÉRAMÉ | FEINSTEINZEUG

BRECCIA NERA



FINITURA LUX		
PBN8	120x278 RT - 48"x109 ^{1/2} "	± 6 mm
PBN2	120x120 RT - 48"x48"	± 9 mm
BE6X	60x120 RT - 24"x48"	± 9 mm
PBX5	75x150 RT - 30"x60"	± 9 mm
BN7X	75x75 RT - 30"x30"	± 9 mm
FINITURA NATURALE R9		
PBN5	75x150 RT - 30"x60"	± 9 mm
BN75	75x75 RT - 30"x30"	± 9 mm

CAPRAIA



FINITURA LUX		
PCX8	120x278 RT - 48"x109 ^{1/2} "	± 6 mm
PCX2	120x120 RT - 48"x48"	± 9 mm
PC6X	60x120 RT - 24"x48"	± 9 mm
PCXP	75x150 RT - 30"x60"	± 9 mm
CP7X	75x75 RT - 30"x30"	± 9 mm
FINITURA NATURALE R9		
CAP5	75x150 RT - 30"x60"	± 9 mm
CR75	75x75 RT - 30"x30"	± 9 mm

PARADISO

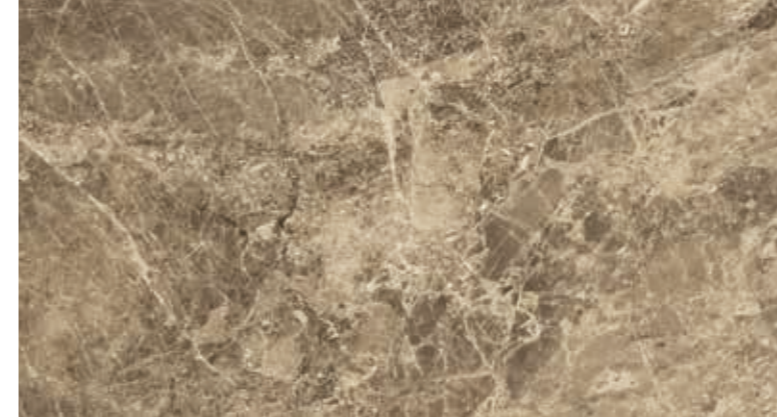

FINITURA LUX		
PPD8	120x278 RT - 48"x109 ^{1/2} "	± 6 mm
PDS2	120x120 RT - 48"x48"	± 9 mm
PP6X	60x120 RT - 24"x48"	± 9 mm
PDX5	75x150 RT - 30"x60"	± 9 mm
PD7X	75x75 RT - 30"x30"	± 9 mm
FINITURA NATURALE R9		
PPD5	75x150 RT - 30"x60"	± 9 mm
PD75	75x75 RT - 30"x30"	± 9 mm

OROBICA GRIGIA



FINITURA LUX		
POG8	120x278 RT - 48"x109 ^{1/2} "	± 6 mm
POX2	120x120 RT - 48"x48"	± 9 mm
OB6X	60x120 RT - 24"x48"	± 9 mm
POGX	75x150 RT - 30"x60"	± 9 mm
OG7X	75x75 RT - 30"x30"	± 9 mm
FINITURA NATURALE R9		
POG5	75x150 RT - 30"x60"	± 9 mm
OG75	75x75 RT - 30"x30"	± 9 mm



TOZZETTO MARMO
TRAVERTINO NOCE



TOZZETTO MARMO
EMPERADOR



TOZZETTO MARMO
NERO MARQUINIA



TOZZETTO MARMO
ROSSO VERONA



TOZZETTO MARMO
BARDIGLIO

TOZZETTI MARMO		
TMTN	travertino noce 6x6 - 2,3"x2,3"	± 7,5 mm
TMEP	emperador 6x6 - 2,3"x2,3"	± 7,5 mm
TMNM	nero marquinia 6x6 - 2,3"x2,3"	± 7,5 mm
TMBA	bardiglio 6x6 - 2,3"x2,3"	± 7,5 mm
TMRV	rosso verona 6x6 - 2,3"x2,3"	± 7,5 mm

PURITY OF MARBLE BRECCE

GRES PORCELLANATO | PORCELAIN TILE | GRÈS CÉRAME | FEINSTEINZEUG

Pezzi speciali

SPECIAL TILES | PIÈCES SPÉCIALES | FORMTEILE

Pezzi speciali disponibili su tutti i colori, su ordinazione.

Trim tiles available in all colors to order.

Pièces spéciales disponibles dans toutes les couleurs, sur demande.

Formteile auf Bestellung in allen Farben verfügbar.



	BRECCIA NERA	CAPRAIA	PARADISO	OROBICA GRIGIA
Gradone C/Prof. Incollato 33x120 RT Lux	BNG1	CPG1	PDG1	OGG1
Ang. Gradone C/Prof.Inc. 33x33 RT Lux	BNAX	CPAX	PDAX	OGAX
Battiscopa TD 7,2x75 Lux	BNB7	CPB7	PSB7	PGB7
Gradone C/Prof. Incollato 33x150 RT	BNG5	CPG5	PDG5	OGG5
Gradone C/Prof Incollato 33x75 RT	BNG7	CPG7	PDG7	OGG7
Ang. Gradone C/Prof.Inc. 33x33 RT	BNA3	CPA3	PDA3	OGA3
Battiscopa TD 7,2x75	BRB6	CP7B	PD7B	OG7B

Imballi

EMBALLAGE | VERPACKUNG | PACKING

PURITY OF MARBLE BRECCE

GRES PORCELLANATO | PORCELAIN TILE | GRÈS CÉRAME | FEINSTEINZEUG

FORMATO	PZ	MQ/PZ	KG/PZ	PZ/CASSA*	MQ/CASSA*	KG/CASSA*	SPESSORE
120x278 RT	1	3,336	49,50	18	60,05	979	6 mm
120x278 RT	1	3,336	49,50	5	16,68	301	6 mm
	* 120x278 fornito in casse di dimensioni 291,6x144,5x33,8 (PxLxH) cm - Peso kg 88 / o in casse per max 5 pz dim.291.6x144.5x24h - peso kg 52,5 * 120x278 supplied in crates. Dimensions crate cm 291,6x144,5x33,8h cm - Weight kg 88 / crates 5 pcs (charge max). Dim.291.6x144.5x24h - Weight kg 52.5						
	PZ	MQ/PZ	KG/PZ	PZ/CAV. **	MQ/CAV. **	KG/CAV. **	SPESSORE
120x278 RT	1	3,336	49,50	18	60,05	1051	6 mm
120x278 RT	1	3,336	49,50	42	40,11	2239	6 mm
	** 120x278 fornito su cavalletti (18 pz o 42 pz - carico max) di dimensioni 290x75x156 (PxLxH) cm - Peso kg 160 ** 120x278 supplied in stand containing (18 pcs or 42 pcs - charge max). Dimensions cm 290x75x156h cm - Weight kg 160						
	PZ/BOX	MQ/BOX	KG/BOX	BOX/PLT	MQ/PLT	KG/PLT	SPESSORE
120x120 RT LUX	2	2,88	60,00	20	57,60	1212	9 mm
60x120 RT LUX	2	1,44	30,00	35	50,40	1062	9 mm
75x150 RT LUX / NAT	2	2,25	46,00	18	40,50	843	9 mm
75x75 RT LUX / NAT	2	1,125	24,00	42	47,25	1020	9 mm
6x6 tozzetto marmo	4	-	-	-	-	-	7,5 mm
7,2x75 battiscopa LUX / NAT	10	7,50 ml	11,00	63	472,50 ml	705	-
33x150 RT gradone c/pr. inc.	2	-	-	-	-	-	-
33x120 RT gradone LUX c/pr. inc.	2	-	-	-	-	-	-
33x75 RT gradone c/profilo incollato	2	-	-	-	-	-	-
33x33 RT ang/gradone c/pr.inc.	4	-	-	-	-	-	-

GRES PORCELLANATO | PORCELAIN TILE | GRÈS CÉRAME | FEINSTEINZEUG

EN 14411 Allegato G . Piastrelle di ceramica pressate a secco con basso assorbimento d'acqua (E ≤ 0,5%)

Gruppo B Ia

Caratteristiche tecniche Technical characteristics	Norma Norms	Superficie Naturale	Superficie Lux (GL)
Resistenza all'abrasione profonda Abrasion resistance	ISO 10545-6	≤ 175 mm ³	-
Determinazione della resistenza all'abrasione superficiale (PEI) Surface abrasion resistance (PEI)		-	Risultati delle prove disponibili in azienda Test details can be obtained from the company
Resistenza allo scivolamento Slip resistance	EN 16165 (previously DIN 51130)	R9	-
Resistenza allo scivolamento Dynamic coefficient of friction (DCOF)	ANSI A326.3	Conforme According to	-
Grado di variazione cromatica Colour shade variation	V1 min - V4 max	Capraia V2 Paradiso V3 - Breccia Nera V3 Orobica Grigia V3	

La finitura superficiale “LUX” è una nuova tecnica di lappatura di ceramiche Supergres, caratterizzata da una superficie a lappatura integrale che esalta i dettagli della grafica. Le piccole picchiettature, le discontinuità e le leggere ondulazioni della superficie del prodotto sono volute per riprodurre fedelmente l'aspetto reale delle pietre e dei marmi antichi levigati donando al prodotto un aspetto ancora più naturale.

La finitura LUX è consigliata per l'utilizzo a pavimento negli ambienti residenziali e negli ambienti dove non siano richieste delle particolari prestazioni antiscivolo. Per le sue caratteristiche, la finitura LUX é raccomandata solo in ambienti interni e non a diretto contatto con l'esterno, in modo da preservare la brillantezza della superficie.

The “LUX” surface finish is a new honing technique by Ceramiche Supergres that sets itself apart thanks to an integral honing on the surface that exalts the graphic details. The light speckles, the random effect and slight waves on the surface of the product are intentional and created to faithfully reproduce the aspect of age-old polished stones and marble, giving the product an even more natural look. The LUX surface finish is recommended for floor application in residential venues and in locations where special anti-slip performance is not required. Due to these features, in order to maintain the brilliance of the LUX surface finish, it is only suitable for indoor use and not for use in direct contact with outdoor areas.

Avvertenze per la posa lastre 120x278RT a pag. 335.

Raccomandation for installation slabs 120x278 RT on page 335.

Recommandations pour la pose des plaques 120x278 à la page 335.

Hinweise zum Verlegen 120x278 RT auf Seite 335.

Purity of Marble ÉLITE



RIVESTIMENTO
Eden Lux 120x278 RT . 48"x109 1/2"

PAVIMENTO
Eden Lux 120x120 RT . 48"x48"

PURITY OF MARBLE ÉLITE

GRES PORCELLANATO | PORCELAIN TILE | GRÈS CÉRAMÉ | FEINSTEINZEUG
EN 14411 Allegato G . Piastrelle di ceramica pressate a secco con basso assorbimento d'acqua (E ≤ 0,5%) | Gruppo B la



PATAGONIA



EDEN



GREEN CALACATTA



120x278 RT
÷ 9 mm



120x120 RT
÷ 9 mm



60x120 RT
÷ 9 mm

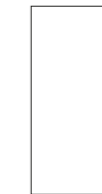

75x150 RT
÷ 9 mm



75x75 RT
÷ 9 mm

SUPERFICIE LUX | LUX SURFACE FINISH | FINITION LUX | OBERFLÄCHE LUX



75x150 RT
÷ 9 mm



75x75 RT
÷ 9 mm

SUPERFICIE NATURALE | NATURAL SURFACE FINISH | SURFACE NATURELLE | NATÜRLICHE OBERFLÄCHE

PURITY OF MARBLE ÉLITE

Eden Lux 120x120 RT . 48"x48"



RIVESTIMENTO
Patagonia lux 120x278 RT . 48"x109 1/2"
Love white 120x278 RT . 48"x109 1/2" Serie Colover

PAVIMENTO
Patagonia Lux 120x120 RT . 48"x48"



RIVESTIMENTO
Green Calacatta lux 120x278 RT . 48"x109 1/2"

PAVIMENTO
Green Calacatta lux 120x120 RT . 48"x48"



PURITY OF MARBLE ÉLITE

GRES PORCELLANATO | PORCELAIN TILE | GRÈS CÉRAMÉ | FEINSTEINZEUG

PATAGONIA



FINITURA LUX		
PPX8	120x278 RT - 48"x109 1/2"	± 6 mm
PPX1	120x120 RT - 48"x48"	± 9 mm
PT6X	60x120 RT - 24"x48"	± 9 mm
PTX5	75x150 RT - 30"x60"	± 9 mm
PTX7	75x75 RT - 30"x30"	± 9 mm
SET VEIN MATCHING LUX COMP. 4/PZ.		
VMPX	120x278 RT - 48"x109 1/2"	± 6 mm
FINITURA NATURALE R9		
PTG5	75x150 RT - 30"x60"	± 9 mm
PTG7	75x75 RT - 30"x30"	± 9 mm

EDEN



FINITURA LUX		
PEX8	120x278 RT - 48"x109 1/2"	± 6 mm
PEX1	120x120 RT - 48"x48"	± 9 mm
ED6X	60x120 RT - 24"x48"	± 9 mm
PEX5	75x150 RT - 30"x60"	± 9 mm
PEX7	75x75 RT - 30"x30"	± 9 mm
SET VEIN MATCHING LUX COMP. 4/PZ.		
VMDX	120x278 RT - 48"x109 1/2"	± 6 mm
FINITURA NATURALE R9		
PED5	75x150 RT - 30"x60"	± 9 mm
PED7	75x75 RT - 30"x30"	± 9 mm

GREEN CALACATTA



FINITURA LUX		
PGX8	120x278 RT - 48"x109 1/2"	± 6 mm
PGX1	120x120 RT - 48"x48"	± 9 mm
GC6X	60x120 RT - 24"x48"	± 9 mm
PGC5	75x150 RT - 30"x60"	± 9 mm
PGX7	75x75 RT - 30"x30"	± 9 mm
SET VEIN MATCHING LUX COMP. 4/PZ.		
GCVX	120x278 RT - 48"x109 1/2"	± 6 mm
FINITURA NATURALE R9		
PGR5	75x150 RT - 30"x60"	± 9 mm
PGC7	75x75 RT - 30"x30"	± 9 mm

SET VEIN MATCHING COMP. 4/PZ.

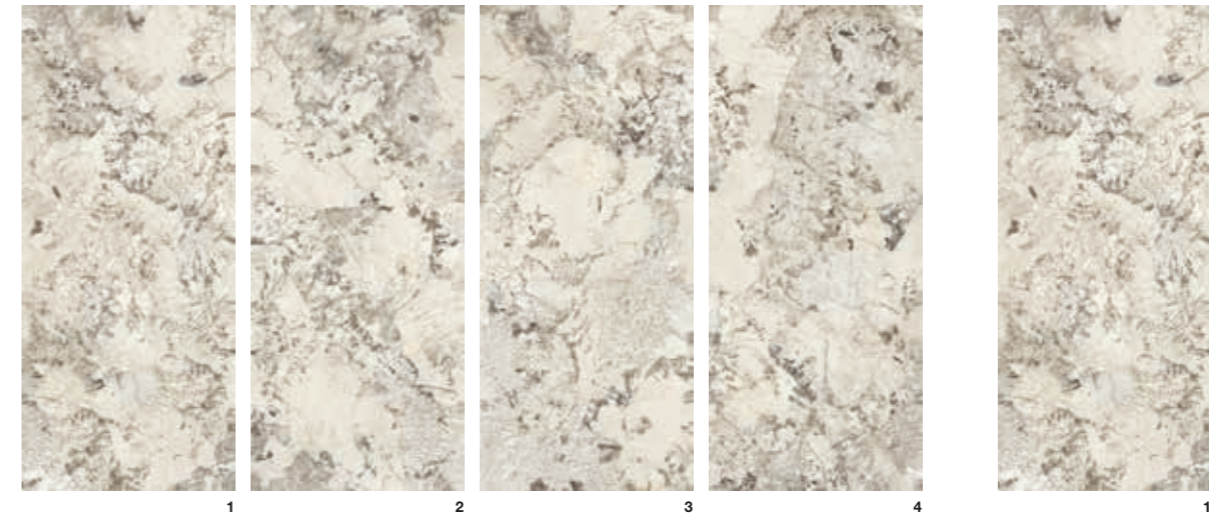

SET VEIN MATCHING LUX COMP. 4/PZ.		
VMPX	120x278 RT - 48"x109 1/2"	± 6 mm



SET VEIN MATCHING LUX COMP. 4/PZ.		
VMDX	120x278 RT - 48"x109 1/2"	± 6 mm

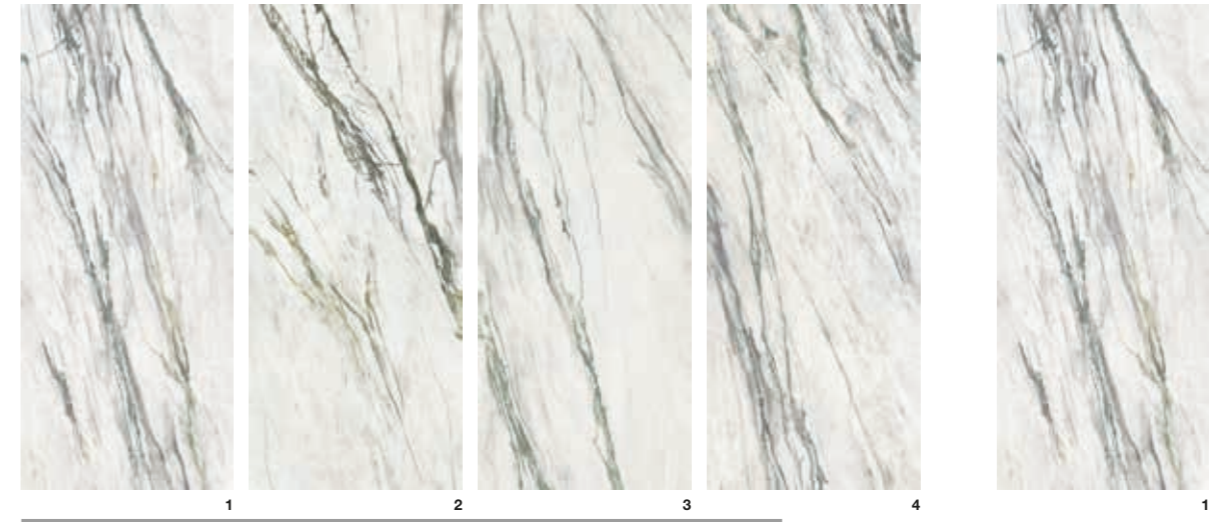

SET VEIN MATCHING LUX COMP. 4/PZ.		
GCVX	120x278 RT - 48"x109 1/2"	± 6 mm

Nei colori Patagonia, Eden e Green Calacatta è possibile posare le lastre con disegno continuo tra un pezzo e l'altro, come nei marmi più pregiati. Eventuali disallineamenti tra le venature sono da considerarsi caratteristica intrinseca del prodotto. L'inserimento delle lastre nelle confezioni è casuale, pertanto Supergres non garantisce le tipologie di facce presenti all'interno di ogni singola confezione. L'immagine rappresentata serve a dare un'idea indicativa del prodotto, toni e venature possono essere quindi suscettibili di variazioni.

In the Patagonia, Eden and Green Calacatta colours, the slabs can be installed with a continuous design from one piece to the next, just as in the most prized marbles. Any mismatches between vein patterns should be considered to be intrinsic characteristics of the product. The order in which the slabs are packed is random, so Supergres does not guarantee the types of faces found in each individual pack. The image shown is designed to provide an indicative idea of the product, the colours and vein patterns may therefore vary.

PURITY OF MARBLE ÉLITE

GRES PORCELLANATO | PORCELAIN TILE | GRÈS CÉRAME | FEINSTEINZEUG

Pezzi speciali

SPECIAL TILES | PIÈCES SPÉCIALES | FORMTEILE

Pezzi speciali disponibili su tutti i colori, su ordinazione.

Trim tiles available in all colors to order.

Pièces spéciales disponibles dans toutes les couleurs, sur demande.

Formteile auf Bestellung in allen Farben verfügbar.

	PATAGONIA	EDEN	GREEN CALACATTA
Gradone C/Prof. Incollato 33x120 RT Lux	TGX1	EGX1	GGX1
Ang. Gradone C/Prof.Inc. 33x33 RT Lux	TXGR	EXGR	GCAG
Battiscopa TD 7,2x75 Lux	PPXB	PEXB	PGCB
Gradone C/Prof. Incollato 33x150 RT	PGGR	EGR1	PGCG
Gradone C/Prof Incollato 33x75 RT	PPG7	PEG7	PG7G
Ang. Gradone C/Prof.Inc. 33x33 RT	PGAG	PEAG	PGAC
Battiscopa TD 7,2x75	PPB7	PEB7	GRB7



TOZZETTO MARMO
TRAVERTINO NOCE



TOZZETTO MARMO
EMPERADOR



TOZZETTO MARMO
NERO MARQUINIA



TOZZETTO MARMO
ROSSO VERONA



TOZZETTO MARMO
BARDIGLIO

TOZZETTI MARMO		
TMTN	travertino noce 6x6 - 2,3"x2,3"	± 7,5 mm
TMEP	emperador 6x6 - 2,3"x2,3"	± 7,5 mm
TMNM	nero marquinia 6x6 - 2,3"x2,3"	± 7,5 mm
TMBA	bardiglio 6x6 - 2,3"x2,3"	± 7,5 mm
TMRV	rosso verona 6x6 - 2,3"x2,3"	± 7,5 mm

La finitura superficiale "LUX" è una nuova tecnica di lappatura di ceramiche Supergres, caratterizzata da una superficie a lappatura integrale che esalta i dettagli della grafica. Le piccole picchiettature, le discontinuità e le leggere ondulazioni della superficie del prodotto sono volute per riprodurre fedelmente l'aspetto reale delle pietre e dei marmi antichi levigati donando al prodotto un aspetto ancora più naturale.

La finitura LUX è consigliata per l'utilizzo a pavimento negli ambienti residenziali e negli ambienti dove non siano richieste delle particolari prestazioni antiscivolo. Per le sue caratteristiche, la finitura LUX é raccomandata solo in ambienti interni e non a diretto contatto con l'esterno, in modo da preservare la brillantezza della superficie.

The "LUX" surface finish is a new honing technique by Ceramiche Supergres that sets itself apart thanks to an integral honing on the surface that exalts the graphic details. The light speckles, the random effect and slight waves on the surface of the product are intentional and created to faithfully reproduce the aspect of age-old polished stones and marble, giving the product an even more natural look. The LUX surface finish is recommended for floor application in residential venues and in locations where special anti-slip performance is not required. Due to these features, in order to maintain the brilliance of the LUX surface finish, it is only suitable for indoor use and not for use in direct contact with outdoor areas.

Avvertenze per la posa lastre 120x278RT a pag. 335.

Raccomandation for installation slabs 120x278 RT on page 335.

Recommandations pour la pose des plaques 120x278 à la page 335.

Hinweise zum Verlegen 120x278 RT auf Seite 335.

Imballi

EMBALLAGE | VERPACKUNG | PACKING

PURITY OF MARBLE ÉLITE

GRES PORCELLANATO | PORCELAIN TILE | GRÈS CÉRAME | FEINSTEINZEUG

FORMATO	PZ	MQ/PZ	KG/PZ	PZ/CASSA*	MQ/CASSA*	KG/CASSA*	SPESSORE
120x278 RT	1	3,336	49,50	18	60,05	979	6 mm
120x278 RT	1	3,336	49,50	5	16,68	301	6 mm
120x278 RT set vein matching	1 comp.	13,344	-	-	-	-	6 mm



* 120x278 fornito in casse di dimensioni 291,6x144,5x33,8 (PxLxH) cm - Peso kg 88 / o in casse per max 5 pz dim.291.6x144.5x24h - peso kg 52.5
* 120x278 supplied in crates. Dimensions crate cm 291,6x144,5x33,8h cm - Weight kg 88 / crates 5 pcs (charge max). Dim.291.6x144.5x24h - Weight kg 52.5

	PZ	MQ/PZ	KG/PZ	PZ/CAV. **	MQ/CAV. **	KG/CAV. **	SPESSORE
120x278 RT	1	3,336	49,50	18	60,05	1051	6 mm
120x278 RT	1	3,336	49,50	42	40,11	2239	6 mm



** 120x278 fornito su cavalletti (18 pz o 42 pz - carico max) di dimensioni 290x75x156 (PxLxH) cm - Peso kg 160
** 120x278 supplied in stand containing (18 pcs or 42 pcs - charge max). Dimensions cm 290x75x156h cm - Weight kg 160

	PZ/BOX	MQ/BOX	KG/BOX	BOX/PLT	MQ/PLT	KG/PLT	SPESSORE
120x120 RT LUX	2	2,88	60,00	20	57,60	1212	9 mm
60x120 RT LUX	2	1,44	30,00	35	50,40	1062	9 mm
75x150 RT LUX / NAT	2	2,25	46,00	18	40,50	843	9 mm
75x75 RT LUX / NAT	2	1,125	24,00	42	47,25	1020	9 mm
6x6 tozzetto marmo	4	-	-	-	-	-	7,5 mm
7,2x75 battiscopa LUX / NAT	10	7,50 ml	11,00	63	472,50 ml	705	-
33x150 RT gradone c/pr. inc.	2	-	-	-	-	-	-
33x120 RT gradone LUX c/pr. inc.	2	-	-	-	-	-	-
33x75 RT gradone c/profilo incollato	2	-	-	-	-	-	-
33x33 RT ang/gradone c/pr.inc.	4	-	-	-	-	-	-

GRES PORCELLANATO | PORCELAIN TILE | GRÈS CÉRAME | FEINSTEINZEUG

EN 14411 Allegato G . Piastrelle di ceramica pressate a secco con basso assorbimento d'acqua (E ≤ 0,5%)

Gruppo B Ia

Caratteristiche tecniche Technical characteristics	Norma Norms	Superficie Naturale	Superficie Lux (GL)
Resistenza all'abrasione profonda Abrasion resistance	ISO 10545-6	≤ 175 mm ³	-
Determinazione della resistenza all'abrasione superficiale (PEI) Surface abrasion resistance (PEI)		-	Risultati delle prove disponibili in azienda Test details can be obtained from the company
Resistenza allo scivolamento Slip resistance	EN 16165 (previously DIN 51130)	R9	-
Resistenza allo scivolamento Dynamic coefficient of friction (DCOF)	ANSI A326.3	Conforme According to	-
Grado di variazione cromatica Colour shade variation	V1 min - V4 max	Eden V2 Patagonia V3 - Green Calacatta V3	

Purity of Marble TUSCANY



PURITY OF MARBLE TUSCANY

GRES PORCELLANATO | PORCELAIN TILE | GRÈS CÉRAMÉ | FEINSTEINZEUG
EN 14411 Allegato G . Piastrelle di ceramica pressate a secco con basso assorbimento d'acqua (E ≤ 0,5%) | Gruppo B la

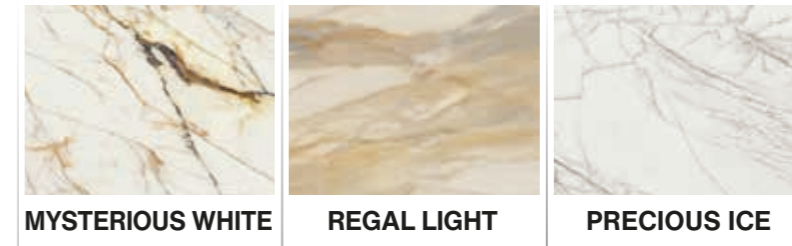

120x278 RT
÷ 6 mm

SUPERFICIE SILK
SILK SURFACE FINISH
FINITION SILK
OBERFLÄCHE SILK



120x278 RT
÷ 6 mm



120x120 RT
÷ 9 mm



60x120 RT
÷ 9 mm



75x150 RT
÷ 9 mm

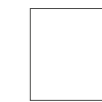

75x75 RT
÷ 9 mm



60x60 RT
÷ 9 mm



30x60 RT
÷ 9 mm

SUPERFICIE LUX | LUX SURFACE FINISH | FINITION LUX | OBERFLÄCHE LUX



75x150 RT
÷ 9 mm



75x75 RT
÷ 9 mm

SUPERFICIE NATURALE | NATURAL SURFACE FINISH | SURFACE NATURELLE | NATÜRLICHE OBERFLÄCHE

PURITY OF MARBLE TUSCANY

GRES PORCELLANATO | PORCELAIN TILE | GRÈS CÉRAMÉ | FEINSTEINZEUG

MYSTERIOUS WHITE



FINITURA LUX		
PMW8	120x278 RT - 48"x109 ^{1/2} "	± 6 mm
MWP1	120x120 RT - 48"x48"	± 9 mm
MWH5	75x150 RT - 30"x60"	± 9 mm
MWH7	75x75 RT - 30"x30"	± 9 mm
PMWY	60x120 RT - 24"x48"	± 9 mm
* MWH6	60x60 RT - 24"x24"	± 9 mm
* OTM6	60x60 RT <i>ottagona</i> - 24"x24"	± 9 mm
* MWH3	30x60 RT - 12"x24"	± 9 mm
FINITURA NATURALE R9		
MYW5	75x150 RT - 30"x60"	± 9 mm
MYW7	75x75 RT - 30"x30"	± 9 mm
SET VEIN MATCHING COMP. 4/PZ.		
PMWV	120x278 RT - 48"x109 ^{1/2} "	± 6 mm

REGAL LIGHT



FINITURA LUX		
PRL8	120x278 RT - 48"x109 ^{1/2} "	± 6 mm
PRL1	120x120 RT - 48"x48"	± 9 mm
RGL5	75x150 RT - 30"x60"	± 9 mm
PRG7	75x75 RT - 30"x30"	± 9 mm
RL6X	60x120 RT - 24"x48"	± 9 mm
* RGL6	60x60 RT - 24"x24"	± 9 mm
* OTR6	60x60 RT <i>ottagona</i> - 24"x24"	± 9 mm
* RGL3	30x60 RT - 12"x24"	± 9 mm
FINITURA NATURALE R9		
REG5	75x150 RT - 30"x60"	± 9 mm
REL7	75x75 RT - 30"x30"	± 9 mm
FINITURA SILK		
PRK8	120x278 RT - 48"x109 ^{1/2} "	± 6 mm
SET VEIN MATCHING LUX COMP. 4/PZ.		
PRVM	120x278 RT - 48"x109 ^{1/2} "	± 6 mm
SET VEIN MATCHING SILK COMP. 4/PZ.		
PRRS	120x278 RT - 48"x109 ^{1/2} "	± 6 mm

PRECIOUS ICE



FINITURA LUX		
PPI8	120x278 RT - 48"x109 ^{1/2} "	± 6 mm
PIX1	120x120 RT - 48"x48"	± 9 mm
PRI5	75x150 RT - 30"x60"	± 9 mm
PRI7	75x75 RT - 30"x30"	± 9 mm
PI6X	60x120 RT - 24"x48"	± 9 mm
* PRI6	60x60 RT - 24"x24"	± 9 mm
* OTI6	60x60 RT <i>ottagona</i> - 24"x24"	± 9 mm
* PRI3	30x60 RT - 12"x24"	± 9 mm
FINITURA NATURALE R9		
PRC5	75x150 RT - 30"x60"	± 9 mm
PRC7	75x75 RT - 30"x30"	± 9 mm
SET VEIN MATCHING COMP. 4/PZ.		
PPVM	120x278 RT - 48"x109 ^{1/2} "	± 6 mm

* Disponibili solo su ordinazione . Available only upon request

SET VEIN MATCHING COMP. 4/PZ.

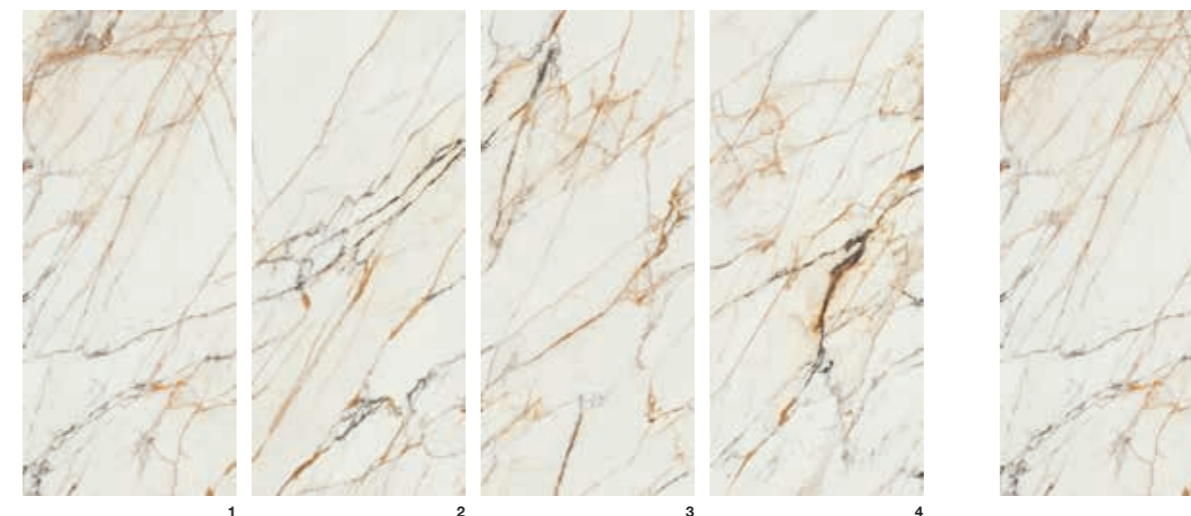

SET VEIN MATCHING COMP. 4/PZ.		
PMWV	120x278 RT - 48"x109 ^{1/2} "	± 6 mm

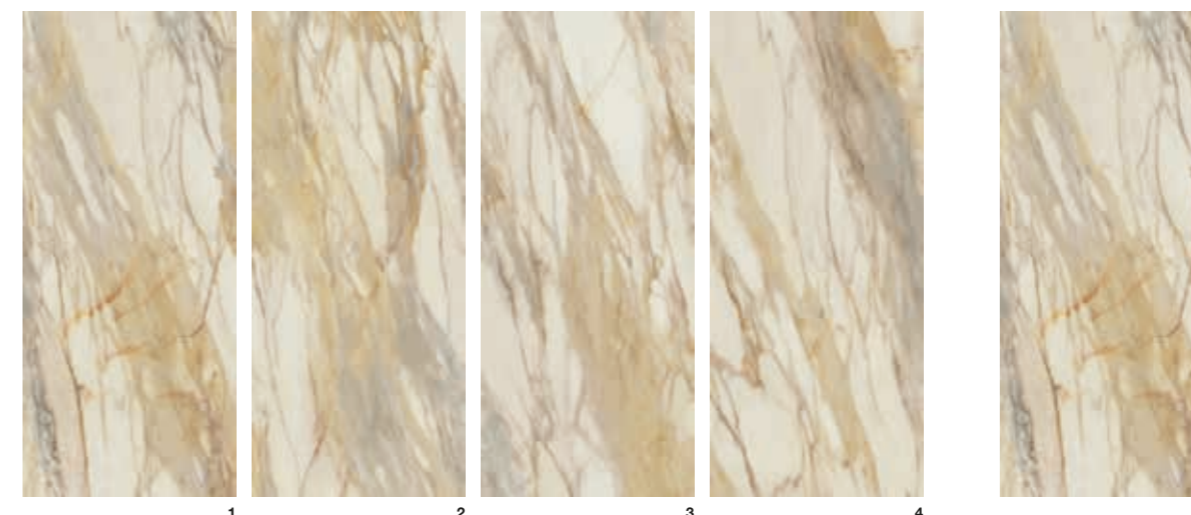

SET VEIN MATCHING LUX COMP. 4/PZ.		
PRVM	120x278 RT - 48"x109 ^{1/2} "	± 6 mm

SET VEIN MATCHING SILK COMP. 4/PZ.		
PRRS	120x278 RT - 48"x109 ^{1/2} "	± 6 mm

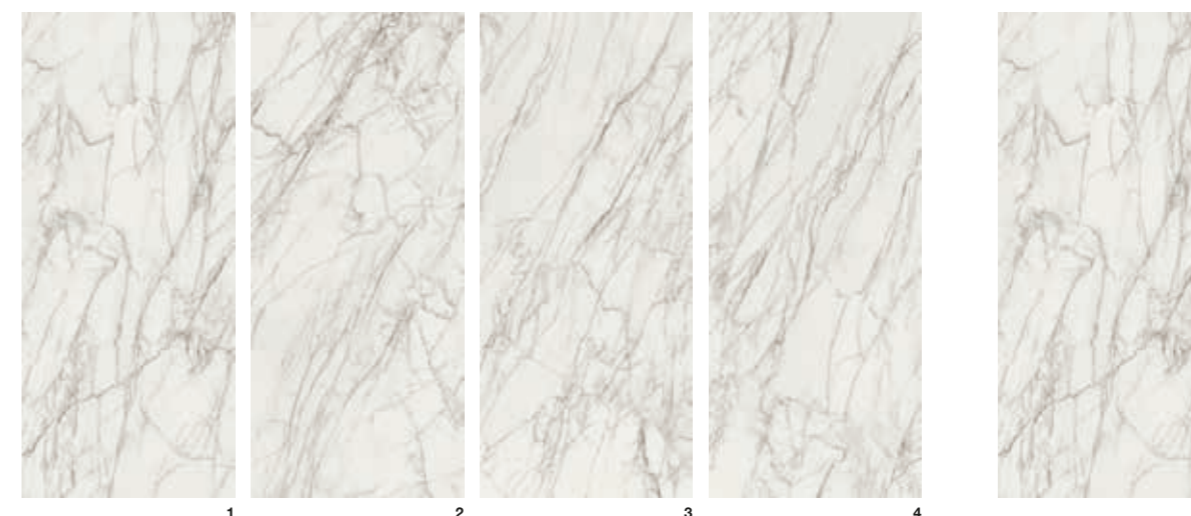

SET VEIN MATCHING COMP. 4/PZ.		
PPVM	120x278 RT - 48"x109 ^{1/2} "	± 6 mm

Nei colori Mysterious White, Regal Light e Precious Ice è possibile posare le lastre con disegno continuo tra un pezzo e l'altro, come nei marmi più pregiati. Eventuali disallineamenti tra le venature sono da considerarsi caratteristica intrinseca del prodotto. L'inserimento delle lastre nelle confezioni è causale, pertanto Supergres non garantisce le tipologie di facce presenti all'interno di ogni singola confezione. L'immagine rappresentata serve a dare un'idea indicativa del prodotto, toni e venature possono essere quindi suscettibili di variazioni.

In the Mysterious White, Regal Light and Precious Ice colours, the slabs can be installed with a continuous design from one piece to the next, just as in the most prized marbles. Any mismatches between vein patterns should be considered to be intrinsic characteristics of the product. The order in which the slabs are packed is random, so Supergres does not guarantee the types of faces found in each individual pack. The image shown is designed to provide an indicative idea of the product, the colours and vein patterns may therefore vary.

PURITY OF MARBLE TUSCANY

GRES PORCELLANATO | PORCELAIN TILE | GRÈS CÉRAME | FEINSTEINZEUG

Pezzi speciali

SPECIAL TILES | PIÈCES SPÉCIALES | FORMTEILE

Pezzi speciali disponibili su tutti i colori, su ordinazione.

Trim tiles available in all colors to order.

Pièces spéciales disponibles dans toutes les couleurs, sur demande.

Formteile auf Bestellung in allen Farben verfügbar.

	MYSTERIOUS WHITE	REGAL LIGHT	PRECIOUS ICE
Gradone C/Prof. Incollato 33x120 RT Lux	PMWG	REGG	PRIG
Gradone C/Prof. Incollato 33x60 RT Lux	MWG6	LG6R	PCG6
Ang. Gradone C/Prof.Inc. 33x33 RT Lux	MWAG	RGA3	PRA3
Gradino 30x60 RT Lux	MGD6	GGR6	PRG6
Battiscopa TD 7,2x75 Lux	MBX7	RBX7	PBX7
Battiscopa TD 7,2x60 Lux	MBX6	RBX6	PBX6
Gradone C/Prof. Incollato 33x150 RT	MWG5	GRL5	PIG5
Gradone C/Prof. Incollato 33x75 RT	MWG7	GRL7	PIG7
Ang. Gradone C/Prof.Inc. 33x33 RT	MHAG	RLG3	PRG3
Battiscopa TD 7,2x75	MW7B	RL7B	PR7B



TOZZETTO MARMO
TRAVERTINO NOCE



TOZZETTO MARMO
EMPERADOR



TOZZETTO MARMO
NERO MARQUINIA



TOZZETTO MARMO
ROSSO VERONA



TOZZETTO MARMO
BARDIGLIO

TOZZETTI MARMO		
TMTN	travertino noce 6x6 - 2,3"x2,3"	± 7,5 mm
TMEP	emperador 6x6 - 2,3"x2,3"	± 7,5 mm
TMNM	nero marquinia 6x6 - 2,3"x2,3"	± 7,5 mm
TMBA	bardiglio 6x6 - 2,3"x2,3"	± 7,5 mm
TMRV	rosso verona 6x6 - 2,3"x2,3"	± 7,5 mm

La finitura superficiale "LUX" è una nuova tecnica di lappatura di ceramiche Supergres, caratterizzata da una superficie a lappatura integrale che esalta i dettagli della grafica. Le piccole picchiettature, le discontinuità e le leggere ondulazioni della superficie del prodotto sono volute per riprodurre fedelmente l'aspetto reale delle pietre e dei marmi antichi levigati donando al prodotto un aspetto ancora più naturale.

La finitura LUX è consigliata per l'utilizzo a pavimento negli ambienti residenziali e negli ambienti dove non siano richieste delle particolari prestazioni antiscivolo. Per le sue caratteristiche, la finitura LUX é raccomandata solo in ambienti interni e non a diretto contatto con l'esterno, in modo da preservare la brillantezza della superficie.

The "LUX" surface finish is a new honing technique by Ceramiche Supergres that sets itself apart thanks to an integral honing on the surface that exalts the graphic details. The light speckles, the random effect and slight waves on the surface of the product are intentional and created to faithfully reproduce the aspect of age-old polished stones and marble, giving the product an even more natural look. The LUX surface finish is recommended for floor application in residential venues and in locations where special anti-slip performance is not required. Due to these features, in order to maintain the brilliance of the LUX surface finish, it is only suitable for indoor use and not for use in direct contact with outdoor areas.

Avvertenze per la posa lastre 120x278RT a pag. 335.

Raccomandation for installation slabs 120x278 RT on page 335.

Recommandations pour la pose des plaques 120x278 à la page 335.

Hinweise zum Verlegen 120x278 RT auf Seite 335.

Imballi

EMBALLAGE | VERPACKUNG | PACKING

PURITY OF MARBLE TUSCANY

GRES PORCELLANATO | PORCELAIN TILE | GRÈS CÉRAME | FEINSTEINZEUG

FORMATO	PZ	MQ/PZ	KG/PZ	PZ/CASSA*	MQ/CASSA*	KG/CASSA*	SPESSORE
120x278 RT LUX / SILK	1	3,336	49,50	18	60,05	979	6 mm
120x278 RT	1	3,336	49,50	5	16,68	301	6 mm
120x278 RT set vein matching comp. 4/pz	1 comp.	13,344	-	-	-	-	6 mm



* 120x278 fornito in casse di dimensioni 291,6x144,5x33,8 (PxLxH) cm - Peso kg 88 / o in casse per max 5 pz dim.291.6x144.5x24h - peso kg 52.5
* 120x278 supplied in crates. Dimensions crate cm 291,6x144,5x33,8h cm - Weight kg 88 / crates 5 pcs (charge max). Dim.291.6x144.5x24h - Weight kg 52.5

	PZ	MQ/PZ	KG/PZ	PZ/CAV. **	MQ/CAV. **	KG/CAV. **	SPESSORE
120x278 RT LUX / SILK	1	3,336	49,50	18	60,05	1051	6 mm
120x278 RT LUX / SILK	1	3,336	49,50	42	140,11	2239	6 mm



** 120x278 fornito su cavalletti (18 pz o 42 pz - carico max) di dimensioni 290x75x156 (PxLxH) cm - Peso kg 160
** 120x278 supplied in stand containing (18 pcs or 42 pcs - charge max). Dimensions cm 290x75x156h cm - Weight kg 160

	PZ/BOX	MQ/BOX	KG/BOX	BOX/PLT	MQ/PLT	KG/PLT	SPESSORE
120x120 RT LUX	2	2,88	60,00	20	57,60	1212	9 mm
60x120 RT LUX	2	1,44	30,00	35	50,40	1062	9 mm
75x150 RT LUX / NAT.	2	2,25	46,00	18	40,50	843	9 mm
75x75 RT LUX / NAT.	2	1,125	23,00	42	47,25	980	9 mm
60x60 RT LUX *	3	1,08	22,50	40	43,20	912	9 mm
30x60 RT LUX *	7	1,26	25,00	40	50,40	1012	9 mm
ottagona 60x60 RT LUX *	3	1,069	21,30	40	42,76	867	9 mm
6x6 tozzetto marmo	4	-	-	-	-	-	7,5 mm
7,2x75 battiscopa TD LUX / NAT.	10	7,50 ml	11,00	63	472,50 ml	705	-
7,2x60 battiscopa TD LUX	10	6,00 ml	9,40	70	420 ml	673	-
33x150 RT gradone c/pr. inc.	2	-	-	-	-	-	-
33x120 RT gradone LUX c/pr. inc.	2	-	-	-	-	-	-
33x75 RT gradone c/profilo incollato	2	-	-	-	-	-	-
33x60 RT gradone c/profilo incollato	4	-	-	-	-	-	-
33x33 RT ang/gradone	4	-	-	-	-	-	-
30x60 RT gradino	7	-	-	-	-	-	-

* **disponibile solo su ordinazione** / available only upon request

GRES PORCELLANATO | PORCELAIN TILE | GRÈS CÉRAME | FEINSTEINZEUG

EN 14411 Allegato G . Piastrelle di ceramica pressate a secco con basso assorbimento d'acqua (E ≤ 0,5%)

Gruppo B Ia

Caratteristiche tecniche Technical characteristics	Norma Norms	Superficie Naturale	Superficie Lux (GL)	Superficie Silk
Resistenza all'abrasione profonda Abrasion resistance	ISO 10545-6	≤ 175 mm ³	-	≤ 175 mm ³
Determinazione della resistenza all'abrasione superficiale (PEI) Surface abrasion resistance (PEI)		-	Risultati delle prove disponibili in azienda Test details can be obtained from the company	-
Resistenza allo scivolamento Slip resistance	EN 16165 (previously DIN 51130)	R9	-	-
Resistenza allo scivolamento Dynamic coefficient of friction (DCOF)	ANSI A326.3	Conforme According to	-	-

Grado di variazione cromatica Colour shade variation	V1 min - V4 max	V2

Stonework



Beola 60x60 RT - 24"x24" - Beola T_20 60x60 RT - 24"x24"

STONWORK

GRES PORCELLANATO | PORCELAIN TILE | GRÈS CÉRAMÉ | FEINSTEINZEUG
EN 14411 Allegato G . Piastrelle di ceramica pressate a secco con basso assorbimento d'acqua (E ≤ 0,5%) | Gruppo B la

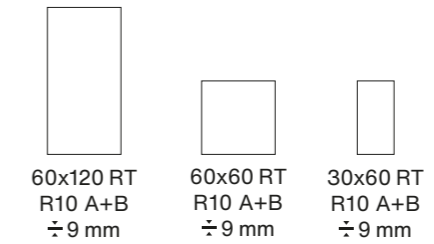
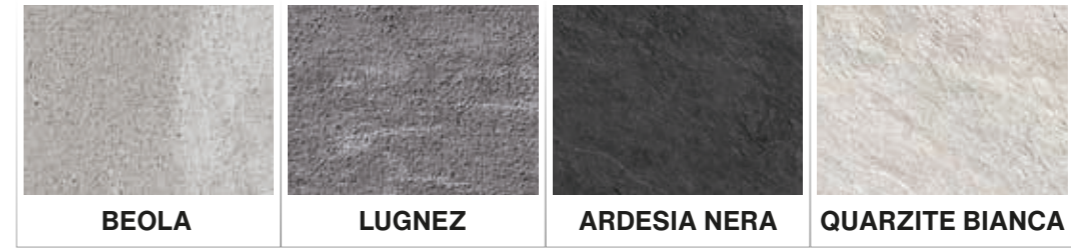

SUPERFICIE NATURALE | NATURAL SURFACE FINISH | SURFACE NATURELLE | NATÜRLICHE OBERFLÄCHE

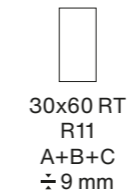

SUPERFICIE GRIP | SURFACE GRIP | SURFACE GRIP | OBERFLÄCHE GRIP

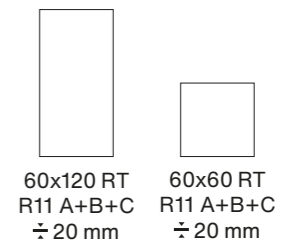

T20 Page n. 294

STONework

PAVIMENTO
Lugnez 30x120 RT . 12"x48"



Quarzite Bianca 30x120 RT . 12"x48"
Northwhite 19.7x120 . 7 3/4"x48"



Ardesia Nera 60x60RT . 24"x24"



STONWORK

GRES PORCELLANATO | PORCELAIN TILE | GRÈS CÉRAME | FEINSTEINZEUG

BEOLA



FINITURA NATURALE R10 A+B		
BE01	60x120 RT - 24"x48"	± 9 mm
BE60	60x60 RT - 24"x24"	± 9 mm
SBL3	30x60 RT - 12"x24"	± 9 mm
FINITURA GRIP R11 A+B+C		
SBTG	30x60 RT - 12"x24"	± 9 mm
FINITURA STRUTTURATA R11 A+B+C * T-20		
BET2	60x120 RT - 24"x48"	± 20 mm
BE6T	60x60 RT - 24"x24"	± 20 mm
MOSAICI		
BMSR	mosaico 30x30 RT - 12"x12"	± 9 mm



Mosaico

FORMATO TESSERA
MOSAIC SIZE
4,8x4,8 - 2"x2"

LUGNEZ

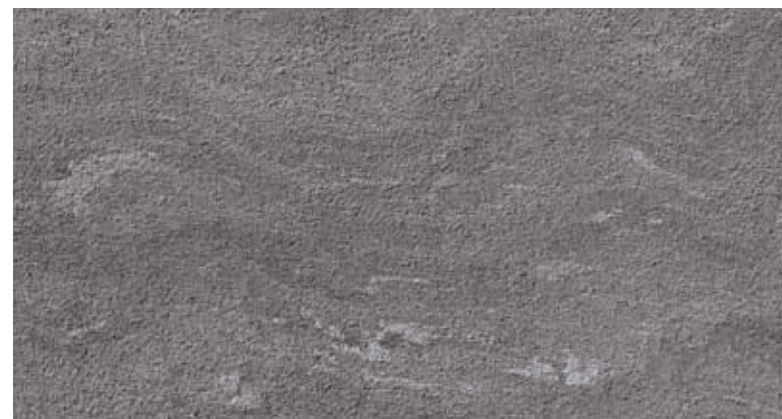

FINITURA NATURALE R10 A+B		
GR12	60x120 RT - 24"x48"	± 9 mm
SLG6	60x60 RT - 24"x24"	± 9 mm
SLU7	30x60 RT - 12"x24"	± 9 mm
FINITURA GRIP R11 A+B+C		
SLG7	30x60 RT - 12"x24"	± 9 mm
FINITURA STRUTTURATA R11 A+B+C * T-20		
LUT2	60x120 RT - 24"x48"	± 20 mm
LUT6	60x60 RT - 24"x24"	± 20 mm
MOSAICI		
LUMS	mosaico 30x30 RT - 12"x12"	± 9 mm



Mosaico

FORMATO TESSERA
MOSAIC SIZE
4,8x4,8 - 2"x2"

ARDESIA NERA

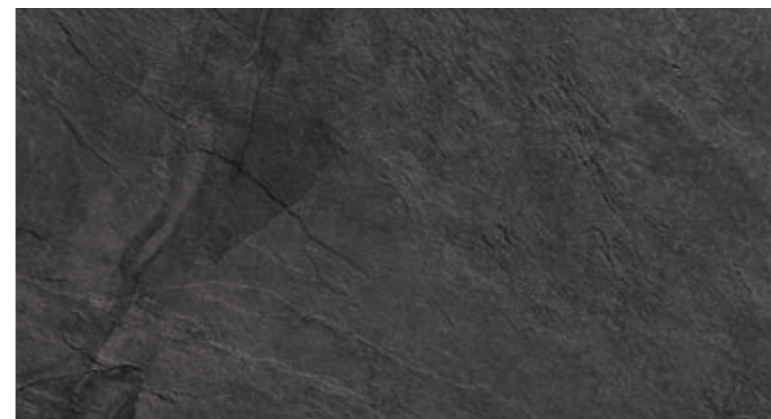

FINITURA NATURALE R10 A+B		
AN12	60x120 RT - 24"x48"	± 9 mm
SAN0	60x60 RT - 24"x24"	± 9 mm
SAN7	30x60 RT - 12"x24"	± 9 mm
FINITURA GRIP R11 A+B+C		
SAG7	30x60 RT - 12"x24"	± 9 mm
FINITURA STRUTTURATA R11 A+B+C * T-20		
TAD2	60x120 RT - 24"x48"	± 20 mm
AN6T	60x60 RT - 24"x24"	± 20 mm
MOSAICI		
RDMB	mosaico 30x30 RT - 12"x12"	± 9 mm



Mosaico

FORMATO TESSERA
MOSAIC SIZE
4,8x4,8 - 2"x2"

QUARZITE BIANCA



FINITURA NATURALE R10 A+B		
QB12	60x120 RT - 24"x48"	± 9 mm
QZB6	60x60 RT - 24"x24"	± 9 mm
SQB7	30x60 RT - 12"x24"	± 9 mm
FINITURA GRIP R11 A+B+C		
SQG7	30x60 RT - 12"x24"	± 9 mm
MOSAICI		
QBMS	mosaico 30x30 RT - 12"x12"	± 9 mm



Mosaico

FORMATO TESSERA
MOSAIC SIZE
4,8x4,8 - 2"x2"

STONework

GRES PORCELLANATO | PORCELAIN TILE | GRÈS CÉRAME | FEINSTEINZEUG

Pezzi speciali

SPECIAL TILES | PIÈCES SPÉCIALES | FORMTEILE

	BEOLA	LUGNEZ	ARDESIA NERA	QUARZITE BIANCA
Gradone C/Prof. Incollato 33x120 RT	BOGR	LNGR	RDGR	QBGR
Gradone Angolare Sinistro 33x120 RT	BOSX	LUSX	ENSX	QBSX
Gradone Angolare Destro 33x120 RT	BOGX	LUDX	ENDX	QBDX
Battiscopa TD 7,2x60	BEB7	LUB7	RBT7	QBT7

GRES PORCELLANATO | PORCELAIN TILE | GRÈS CÉRAME | FEINSTEINZEUG

EN 14411 Allegato G . Piastrelle di ceramica pressate a secco con basso assorbimento d'acqua (E ≤ 0,5%)

Gruppo B Ia

Caratteristiche tecniche Technical characteristics	Norma Norms	Superficie Naturale	Superficie Grip
Resistenza all'abrasione profonda Abrasion resistance	ISO 10545-6	≤ 175 mm ³	≤ 175 mm ³
Resistenza allo scivolamento Slip resistance	EN 16165 (previously DIN 51130)	R10	R11
Resistenza allo scivolamento - Superfici bagnate a piedi scalzi Coefficient of friction - Dry surfaces walking on barefoot	EN 16165 (previously DIN 51097)	A+B	A+B+C
Resistenza allo scivolamento Dynamic coefficient of friction (DCOF)	ANSI A326.3	Conforme According to	Conforme According to
Coefficiente di attrito dinamico Dynamic friction coefficient	METODO B.C.R.A.	Conforme According to	Conforme According to
Grado di variazione cromatica Colour shade variation	V1 min - V4 max	Quarzite Bianca V2 - Ardesia Nera V2 Lugnez V3 - Beola V3	

Imballi

EMBALLAGE | VERPACKUNG | PACKING

STONework

GRES PORCELLANATO | PORCELAIN TILE | GRÈS CÉRAME | FEINSTEINZEUG

	PZ/BOX	MQ/BOX	KG/BOX	BOX/PLT	MQ/PLT	KG/PLT	SPESSORE
60x120 RT	2	1,44	30,00	35	50,40	1062	9 mm
60x60 RT	4	1,44	28,00	30	43,20	852	9 mm
30x60 RT	7	1,26	25,00	40	50,40	1012	9 mm
30x60 RT grip	7	1,26	25,00	40	50,40	1012	9 mm
30x30 RT mosaico su rete	10	0,90	16,00	30	27,00	495	-
33x120 RT gradone c/prof.incollato	2	-	-	-	-	-	-
33x120 RT gradone angolare destro	1	-	-	-	-	-	-
33x120 RT gradone angolare sinistro	1	-	-	-	-	-	-
7,2x60 battiscopa total dek	10	6,00 ml	9,00	70	420 ml	645	-
60x120 RT	1	0,72	32,00	25	25,20	1135	20 mm
60x60 RT	2	0,72	32,00	30	21,60	972	20 mm

AVVERTENZE PER LA POSA - Gres porcellanato

RECOMMENDATIONS FOR INSTALLATION - Porcelain tile

Per la posa del materiale rettificato si prescrive una fuga minima di 2 mm.

As for rectified materials, a minimum joint of 2 mm is required.

Pour la pose du matériau rectifié, il faut réaliser un joint minimum de 2 mm.

Für die Verlegung des geschliffenen Materials ist eine Mindestfuge von 2 mm vorgeschrieben.

Si raccomanda di posare i materiali sfalsati di 20 cm al massimo, mai a metà della loro lunghezza

It is strongly recommended to install the materials in a staggered pattern of a maximum of 20 cm, never at half way its length.

Il est conseillé de poser les matériaux en décalé de 20 cm au maximum, jamais à la moitié de leur longueur.

Es wird empfohlen, die Materialien um höchstens 20 cm versetzt zu verlegen und nie in der Mitte ihrer Länge.

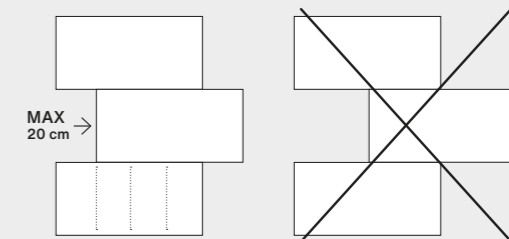

Per maggiori dettagli e aggiornamenti sulle certificazioni, consultare il nostro sito www.supergres.com
For further details and updated information on certifications, please visit our website www.supergres.com
Pour obtenir plus d'informations et de mises à jour sur les certifications, veuillez consulter notre site www.supergres.com
Für weitere Details und Aktualisierungen der Zertifizierungen besuchen Sie bitte unsere Internetseite www.supergres.com

Stoorm



Light 60x60 RT . 24"x24"
Wind 60x60 RT . 24"x24"

STOORM

GRES PORCELLANATO | PORCELAIN TILE | GRÈS CÉRAME | FEINSTEINZEUG
EN 14411 Allegato G . Piastrelle di ceramica pressate a secco con basso assorbimento d'acqua (E ≤ 0,5%) | Gruppo B la



60x60 RT
R10 A+B
±9 mm



30x60 RT
R10 A+B
±9 mm

SUPERFICIE NATURALE | NATURAL SURFACE FINISH | SURFACE NATURELLE | NATÜRLICHE OBERFLÄCHE



30x60
R11 A+B+C
±9 mm

SUPERFICIE STRUTTURATA | STRUCTURED SURFACE FINISH | FINITION STRUCTURÉE | STRUKTURIERTE OBERFLÄCHE

STOORM

GRES PORCELLANATO | PORCELAIN TILE | GRÈS CÉRAMÉ | FEINSTEINZEUG

STOORM SAND



FINITURA NATURALE R10 A+B		
SSN6	60x60 RT - 24"x24"	± 9 mm
SSN7	30x60 RT - 12"x24"	± 9 mm
FINITURA STRUTTURATA R11 A+B+C		
SST7	30x60 - 12"x24"	± 9 mm

STOORM SHADOW



FINITURA NATURALE R10 A+B		
SSW6	60x60 RT - 24"x24"	± 9 mm
SSH7	30x60 RT - 12"x24"	± 9 mm
FINITURA STRUTTURATA R11 A+B+C		
7HS6	30x60 - 12"x24"	± 9 mm

STOORM WIND

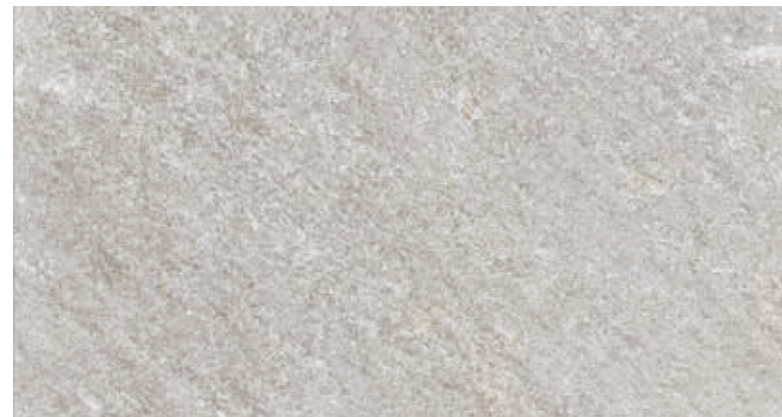

FINITURA NATURALE R10 A+B		
SMD6	60x60 RT - 24"x24"	± 9 mm
SMU7	30x60 RT - 12"x24"	± 9 mm
FINITURA STRUTTURATA R11 A+B+C		
WSS7	30x60 - 12"x24"	± 9 mm

STOORM LIGHT



FINITURA NATURALE R10 A+B		
SLI6	60x60 RT - 24"x24"	± 9 mm
SLI7	30x60 RT - 12"x24"	± 9 mm
FINITURA STRUTTURATA R11 A+B+C		
SML7	30x60 - 12"x24"	± 9 mm

STOORM RAIN



FINITURA NATURALE R10 A+B		
SRN6	60x60 RT - 24"x24"	± 9 mm
SRI7	30x60 RT - 12"x24"	± 9 mm
FINITURA STRUTTURATA R11 A+B+C		
SRS6	30x60 - 12"x24"	± 9 mm

STOORM

GRES PORCELLANATO | PORCELAIN TILE | GRÈS CÉRAME | FEINSTEINZEUG

Pezzi speciali

SPECIAL TILES | PIÈCES SPÉCIALES | FORMTEILE

Pezzi speciali disponibili su tutti i colori, su ordinazione.

Trim tiles available in all colors to order.

Pièces spéciales disponibles dans toutes les couleurs, sur demande.

Formteile auf Bestellung in allen Farben verfügbar.

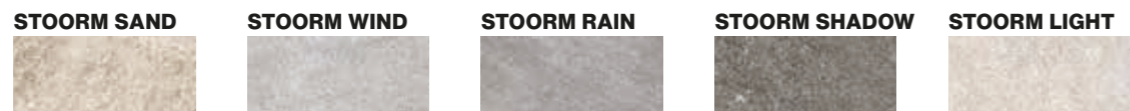
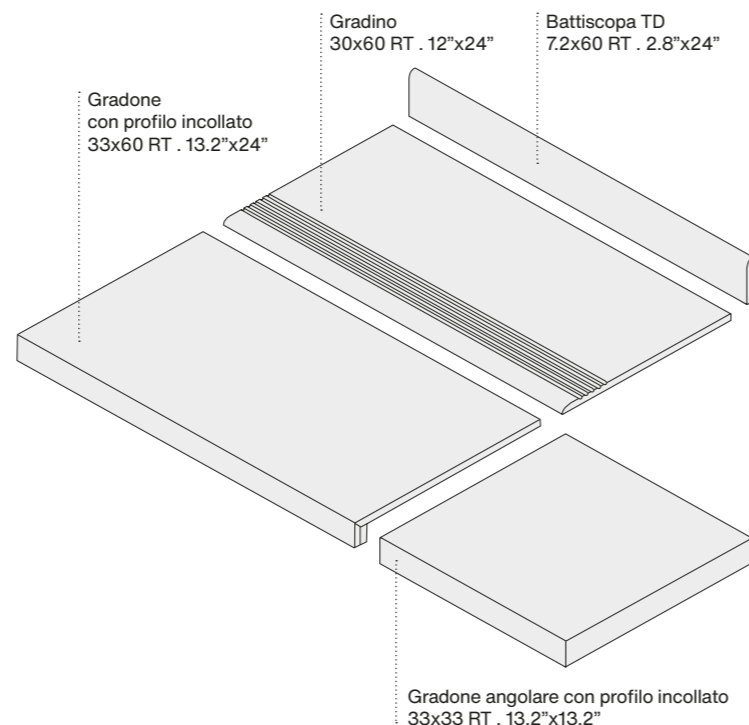

	STOORM SAND	STOORM WIND	STOORM RAIN	STOORM SHADOW	STOORM LIGHT
Gradone c/prof. incollato 33x60 RT	OSG6	OWG6	ORG6	OHG6	OLG6
Ang. Gradone c/prof. inc. 33x33 RT	OAGS	OAGW	OAGN	OAGH	OAGL
Gradino 30x60 RT	OR7S	OR7W	OR7G	OR7H	OR7L
Battiscopa TD 7,2x60	NSBT	SUBT	RSBT	WSHB	LBTI

GRES PORCELLANATO | PORCELAIN TILE | GRÈS CÉRAME | FEINSTEINZEUG

EN 14411 Allegato G . Piastrelle di ceramica pressate a secco con basso assorbimento d'acqua (E ≤ 0,5%)

Gruppo B Ia

Caratteristiche tecniche Technical characteristics	Norma Norms	Superficie Naturale	Superficie Strutturata
Resistenza all'abrasione profonda Abrasion resistance	ISO 10545-6	≤ 175 mm ³	≤ 175 mm ³
Resistenza allo scivolamento Slip resistance	EN 16165 (previously DIN 51130)	R10	R11
Resistenza allo scivolamento - Superfici bagnate a piedi scalzi Coefficient of friction - Dry surfaces walking on barefoot	EN 16165 (previously DIN 51097)	A+B	A+B+C
Resistenza allo scivolamento Dynamic coefficient of friction (DCOF)	ANSI A326.3	Conforme According to	Conforme According to
Coefficiente di attrito dinamico Dynamic friction coefficient	METODO B.C.R.A.	Conforme According to	Conforme According to
Grado di variazione cromatica Colour shade variation	V1 min - V4 max	V4	

Imballi

EMBALLAGE | VERPACKUNG | PACKING

STOORM

GRES PORCELLANATO | PORCELAIN TILE | GRÈS CÉRAME | FEINSTEINZEUG

	PZ/BOX	MQ/BOX	KG/BOX	BOX/PLT	MQ/PLT	KG/PLT	SPESSORE
60x60 RT	3	1,08	22,00	40	43,20	892	9 mm
30x60 RT	7	1,26	25,00	40	50,40	1012	9 mm
30x60 struttura	7	1,26	25,00	40	50,40	1012	9 mm
33x60 RT gradone c/prof.incollato	4	-	-	-	-	-	-
33x33 RT ang.gradone c/prof.inc.	4	-	-	-	-	-	-
30x60 RT gradino	7	-	-	-	-	-	-
7,2x60 battiscopa total dek	10	6,00 ml	9,00	70	420 ml	645	-

AVVERTENZE PER LA POSA - Gres porcellanato

RECOMMENDATIONS FOR INSTALLATION - Porcelain tile

Per la posa del materiale rettificato si prescrive una fuga minima di 2 mm.

As for rectified materials, a minimum joint of 2 mm is required.

Pour la pose du matériau rectifié, il faut réaliser un joint minimum de 2 mm.

Für die Verlegung des geschliffenen Materials ist eine Mindestfuge von 2 mm vorgeschrieben.

Si raccomanda di posare i materiali sfalsati di 20 cm al massimo, mai a metà della loro lunghezza

It is strongly recommended to install the materials in a staggered pattern of a maximum of 20 cm, never at half way its length.

Il est conseillé de poser les matériaux en décalé de 20 cm au maximum, jamais à la moitié de leur longueur.

Es wird empfohlen, die Materialien um höchstens 20 cm versetzt zu verlegen und nie in der Mitte ihrer Länge.

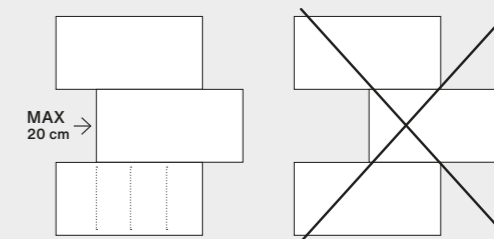

Per maggiori dettagli e aggiornamenti sulle certificazioni, consultare il nostro sito www.supergres.com
For further details and updated information on certifications, please visit our website www.supergres.com
Pour obtenir plus d'informations et de mises à jour sur les certifications, veuillez consulter notre site www.supergres.com
Für weitere Details und Aktualisierungen der Zertifizierungen besuchen Sie bitte unsere Internetseite www.supergres.com

Story



ASTE
LASSES



Story Dark 75x75 RT . 30"x30"
Story Dark Brick 7.5x30 RT . 3"x12"

STORY

GRES PORCELLANATO | PORCELAIN TILE | GRÈS CÉRAME | FEINSTEINZEUG
EN 14411 Allegato G . Piastrelle di ceramica pressate a secco con basso assorbimento d'acqua (E ≤ 0,5%) | Gruppo B la

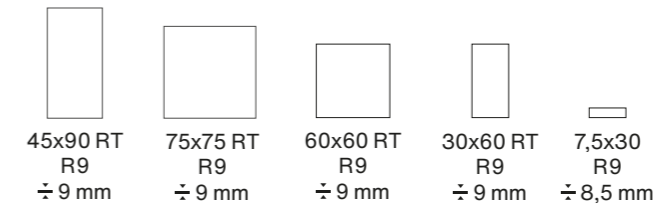

SUPERFICIE NATURALE | NATURAL SURFACE FINISH | SURFACE NATURELLE | NATÜRLICHE OBERFLÄCHE

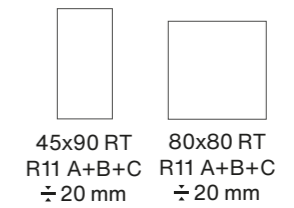
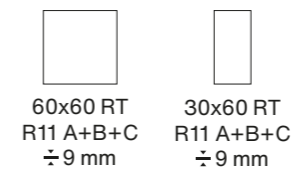

* SUPERFICIE GRIP | SURFACE GRIP | SURFACE GRIP | OBERFLÄCHE GRIP

* **disponibile solo su ordinazione** / available only upon request

T.20 Page n. 298

STORY

GRES PORCELLANATO | PORCELAIN TILE | GRÈS CÉRAMÉ | FEINSTEINZEUG

STORY BRONZE



FINITURA NATURALE R9		
STB7	75x75 RT - 30"x30"	± 9 mm
SBR9	45x90 RT - 18"x36"	± 9 mm
SBR6	60x60 RT - 24"x24"	± 9 mm
BSR7	30x60 RT - 12"x24"	± 9 mm
SBR7	brick 7,5x30 - 3"x12"	± 9 mm
* FINITURA GRIP R11 A+B+C		
SB6G	60x60 RT - 24"x24"	± 9 mm
SBG7	30x60 RT - 12"x24"	± 9 mm
MOSAICI		
SBRM	mosaico 30x30 RT - 12"x12"	± 9 mm

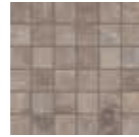

Mosaico

FORMATO TESSERA
MOSAIC SIZE
4,8x4,8 - 2"x2"

STORY IVORY



FINITURA NATURALE R9		
STI7	75x75 RT - 30"x30"	± 9 mm
SIV9	45x90 RT - 18"x36"	± 9 mm
SIV6	60x60 RT - 24"x24"	± 9 mm
SI07	30x60 RT - 12"x24"	± 9 mm
SIV7	brick 7,5x30 - 3"x12"	± 9 mm
* FINITURA GRIP R11 A+B+C		
ST6G	60x60 RT - 24"x24"	± 9 mm
ST7G	30x60 RT - 12"x24"	± 9 mm
FINITURA STRUTTURATA T20 R11 A+B+C * T20		
CMA8	80x80 RT -32"x32"	± 20 mm
STI4	45x90 RT - 18"x36"	± 20 mm
MOSAICI		
SVB3	mosaico 30x30 RT - 12"x12"	± 9 mm

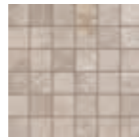

Mosaico

FORMATO TESSERA
MOSAIC SIZE
4,8x4,8 - 2"x2"

* disponibile solo su ordinazione / available only upon request

STORY GREY



FINITURA NATURALE R9		
STG7	75x75 RT - 30"x30"	± 9 mm
SGY9	45x90 RT - 18"x36"	± 9 mm
SGE6	60x60 RT - 24"x24"	± 9 mm
SGY7	30x60 RT - 12"x24"	± 9 mm
SGR7	brick 7,5x30 - 3"x12"	± 9 mm
* FINITURA GRIP R11 A+B+C		
SG6G	60x60 RT - 24"x24"	± 9 mm
SG37	30x60 RT - 12"x24"	± 9 mm
FINITURA STRUTTURATA R11 A+B+C * T20		
AGH8	80x80 RT -32"x32"	± 20 mm
S2G4	45x90 RT - 18"x36"	± 20 mm
MOSAICI		
SGYM	mosaico 30x30 RT - 12"x12"	± 9 mm

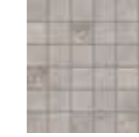

Mosaico

FORMATO TESSERA
MOSAIC SIZE
4,8x4,8 - 2"x2"

STORY DARK



FINITURA NATURALE R9		
STD7	75x75 RT - 30"x30"	± 9 mm
SDA9	45x90 RT - 18"x36"	± 9 mm
SDA6	60x60 RT - 24"x24"	± 9 mm
SKD7	30x60 RT - 12"x24"	± 9 mm
SDA7	brick 7,5x30 - 3"x12"	± 9 mm
MOSAICI		
SDKM	mosaico 30x30 RT - 12"x12"	± 9 mm

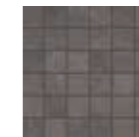

Mosaico

FORMATO TESSERA
MOSAIC SIZE
4,8x4,8 - 2"x2"

* Gamma completa Story T20 a pagina 298 / For the complete range Story T20 go to page 298

STORY

GRES PORCELLANATO | PORCELAIN TILE | GRÈS CÉRAME | FEINSTEINZEUG

Pezzi speciali

SPECIAL TILES | PIÈCES SPÉCIALES | FORMTEILE

Pezzi speciali disponibili su tutti i colori, su ordinazione.

Trim tiles available in all colors to order.

Pièces spéciales disponibles dans toutes les couleurs, sur demande.

Formteile auf Bestellung in allen Farben verfügbar.

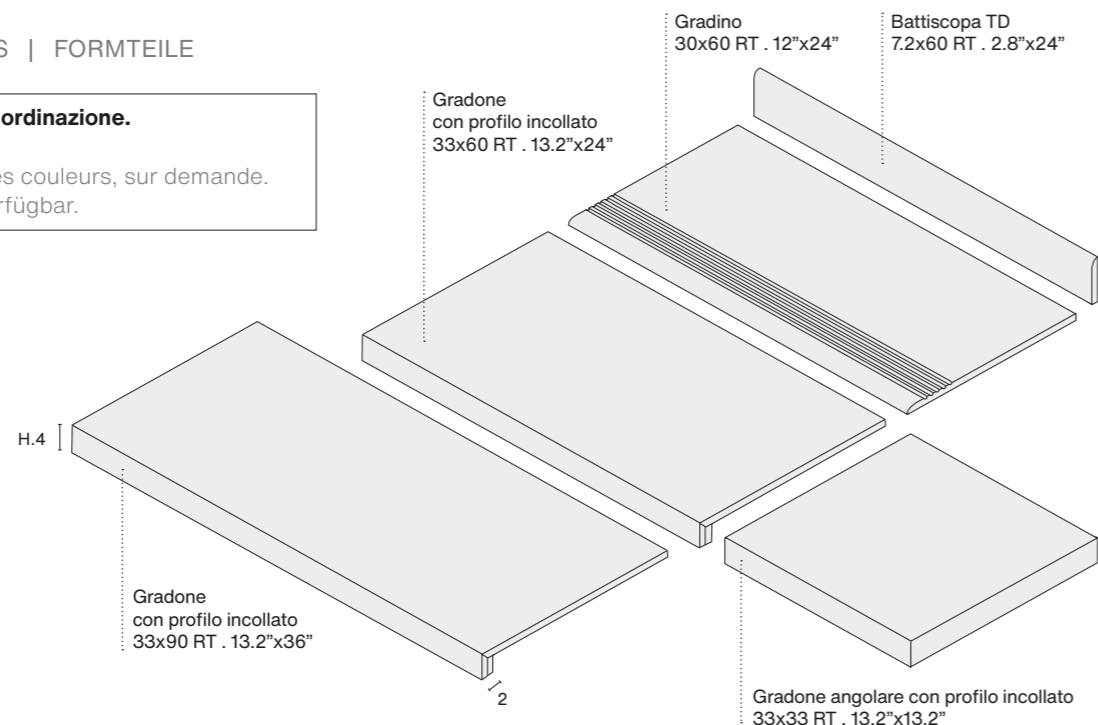

	STORY IVORY	STORY BRONZE	STORY GREY	STORY DARK
Gradone C/Prof. Incollato 33x90 RT	SIG9	SBG9	SGG9	SDG9
Gradone C/Prof. Incollato 33x60 RT	SG6P	SBG6	SGGP	SGD6
Ang. Gradone c/prof. inc. 33x33 RT	SIA3	SBZG	RGY3	SDKG
Gradino 30x60 RT	SIGD	SIBD	SIRD	KDGR
Battiscopa TD 7,2x60	SIB7	SBB7	SGB7	SDT7

GRES PORCELLANATO | PORCELAIN TILE | GRÈS CÉRAME | FEINSTEINZEUG

EN 14411 Allegato G . Piastrelle di ceramica pressate a secco con basso assorbimento d'acqua (E ≤ 0,5%)

Gruppo B la

Caratteristiche tecniche Technical characteristics	Norma Norms	Superficie Naturale	Superficie Grip
Resistenza all'abrasione profonda Abrasion resistance	ISO 10545-6	≤ 175 mm ³	≤ 175 mm ³
Resistenza allo scivolamento Slip resistance	EN 16165 (previously DIN 51130)	R9	R11
Resistenza allo scivolamento - Superfici bagnate a piedi scalzi Coefficient of friction - Dry surfaces walking on barefoot	EN 16165 (previously DIN 51097)	-	A+B+C
Resistenza allo scivolamento Dynamic coefficient of friction (DCOF)	ANSI A326.3	Conforme According to	Conforme According to
Coefficiente di attrito dinamico Dynamic friction coefficient	METODO B.C.R.A.	Conforme According to	Conforme According to
Grado di variazione cromatica Colour shade variation	V1 min - V4 max	V3	

Imballi

EMBALLAGE | VERPACKUNG | PACKING

STORY

GRES PORCELLANATO | PORCELAIN TILE | GRÈS CÉRAME | FEINSTEINZEUG

	PZ/BOX	MQ/BOX	KG/BOX	BOX/PLT	MQ/PLT	KG/PLT	SPESSORE
75x75 RT	2	1,125	22,30	42	47,25	952	9 mm
45x90 RT	3	1,215	24,00	36	43,74	879	9 mm
60x60 RT	3	1,08	21,00	40	43,20	852	9 mm
30x60 RT	7	1,26	25,00	40	50,40	1012	9 mm
60x60 RT grip	3	1,08	21,00	40	43,20	852	9 mm
30x60 RT grip	7	1,26	25,00	40	50,40	1012	9 mm
7,5x30	48	1,08	19,50	48	51,84	948	8,5 mm
30x30 RT mosaico su rete	10	0,90	16,00	30	27,00	495	-
7,2x60 battiscopa total dek	10	6,00 ml	9,00	70	420 ml	645	-
gradino 30x60 RT	7	-	-	-	-	-	-
gradone c/prof.incollato 33x90	2	-	-	-	-	-	-
gradone c/prof.incollato 33x60	4	-	-	-	-	-	-
ang/grad c/prof.inc. 33x33	4	-	-	-	-	-	-
45x90 RT	2	0,81	35,00	27	21,87	960	20 mm
80x80 RT	1	0,64	29,70	42	26,88	1262	20 mm

AVVERTENZE PER LA POSA - Gres porcellanato

RECOMMENDATIONS FOR INSTALLATION - Porcelain tile

Per la posa del materiale rettificato si prescrive una fuga minima di 2 mm.

As for rectified materials, a minimum joint of 2 mm is required.

Pour la pose du matériau rectifié, il faut réaliser un joint minimum de 2 mm.

Für die Verlegung des geschliffenen Materials ist eine Mindestfuge von 2 mm vorgeschrieben.

Si raccomanda di posare i materiali sfalsati di 20 cm al massimo, mai a metà della loro lunghezza

It is strongly recommended to install the materials in a staggered pattern of a maximum of 20 cm, never at half way its length.

Il est conseillé de poser les matériaux en décalé de 20 cm au maximum, jamais à la moitié de leur longueur.

Es wird empfohlen, die Materialien um höchstens 20 cm versetzt zu verlegen und nie in der Mitte ihrer Länge.

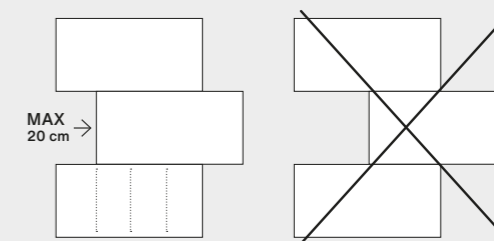

Per maggiori dettagli e aggiornamenti sulle certificazioni, consultare il nostro sito www.supergres.com
For further details and updated information on certifications, please visit our website www.supergres.com
Pour obtenir plus d'informations et de mises à jour sur les certifications, veuillez consulter notre site www.supergres.com
Für weitere Details und Aktualisierungen der Zertifizierungen besuchen Sie bitte unsere Internetseite www.supergres.com

Travel



Westbrown 19.7x120 RT - 7 3/4"x48"
Westbrown 14.7x120 RT - 5 3/4"x48"

TRAVEL

GRES PORCELLANATO | PORCELAIN TILE | GRÈS CÉRAME | FEINSTEINZEUG
EN 14411 Allegato G . Piastrelle di ceramica pressate a secco con basso assorbimento d'acqua (E ≤ 0,5%) | Gruppo B la

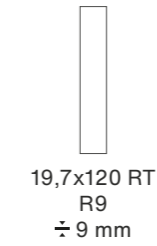

SUPERFICIE NATURALE | NATURAL SURFACE FINISH | SURFACE NATURELLE | NATÜRLICHE OBERFLÄCHE

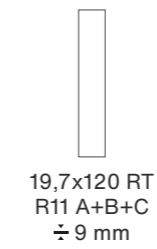

SUPERFICIE STRUTTURATA | STRUCTURED | SURFACE FINISH
FINITION STRUCTURÉE | STRUKTURIERTE OBERFLÄCHE

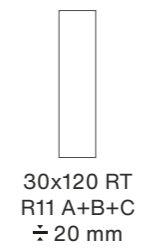

T.20 Page n. 302

TRAVEL

Northwhite 19.7x120 RT . 7 3/4"x48" - 14.7x120 RT . 5 3/4"x48"



Eastgrey 19.7x120 RT . 7 3/4"x48"



Southgold Strutturato 19,7x120 RT . 7 3/4"x48"



TRAVEL

GRES PORCELLANATO | PORCELAIN TILE | GRÈS CÉRAMÉ | FEINSTEINZEUG

NORTHWHITE



FINITURA NATURALE R9			
TNW2	19,7x120 RT - 7 3/4"x48"		± 9 mm
FINITURA STRUTTURATA R11 A+B+C			
TNWS	19,7x120 RT - 7 3/4"x48"		± 9 mm

SOUTHGOLD



FINITURA NATURALE R9			
TSG2	19,7x120 RT - 7 3/4"x48"		± 9 mm
FINITURA STRUTTURATA R11 A+B+C			
TSGS	19,7x120 RT - 7 3/4"x48"		± 9 mm
FINITURA STRUTTURATA R11 A+B+C * T.20			
S30T	30x120 RT - 12"x48" T20		± 20 mm

EASTGREY



FINITURA NATURALE R9			
TEG1	19,7x120 RT - 7 3/4"x48"		± 9 mm
FINITURA STRUTTURATA R11 A+B+C			
TEG2	19,7x120 RT - 7 3/4"x48"		± 9 mm
FINITURA STRUTTURATA R11 A+B+C * T.20			
E30T	30x120 RT - 12"x48" T20		± 20 mm

WESTBROWN

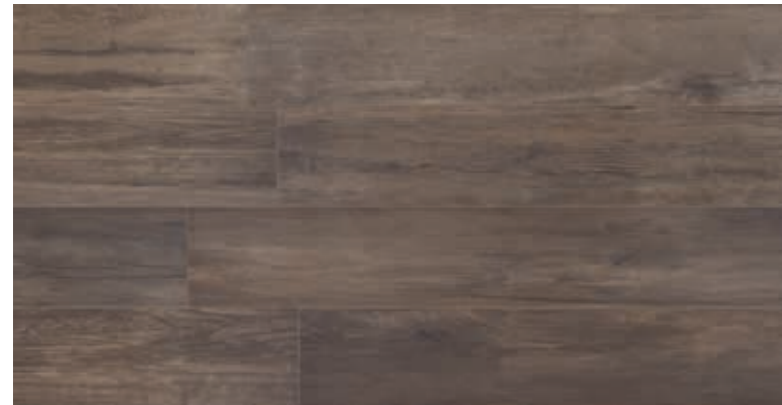

FINITURA NATURALE R9			
TSB2	19,7x120 RT - 7 3/4"x48"		± 9 mm
FINITURA STRUTTURATA R11 A+B+C			
TSBS	19,7x120 RT - 7 3/4"x48"		± 9 mm

Pezzi speciali

SPECIAL TILES | PIÈCES SPÉCIALES | FORMTEILE

	NORTHWHITE	SOUTHGOLD	EASTGREY	WESTBROWN
				
Battiscopa TD 9,5x60	NWBT	SOBT	EABT	WEBT

Imballi

EMBALLAGE | VERPACKUNG | PACKING

TRAVEL

GRES PORCELLANATO | PORCELAIN TILE | GRÈS CÉRAMÉ | FEINSTEINZEUG

FORMATO	PZ/BOX	MQ/BOX	KG/BOX	BOX/PLT	MQ/PLT	KG/PLT	SPESSORE
19,7x120 RT	6	1,42	29,00	32	45,39	940	9 mm
19,7x120 RT strutturato	6	1,42	29,00	32	45,39	940	9 mm
9,5x60 battiscopa	8	4,80 ml	9,50	84	403,20 ml	810	-
30x120 RT	2	0,72	32,00	36	25,92	1167	20 mm

GRES PORCELLANATO | PORCELAIN TILE | GRÈS CÉRAMÉ | FEINSTEINZEUG

EN 14411 Allegato G . Piastrelle di ceramica pressate a secco con basso assorbimento d'acqua (E ≤ 0,5%)

Gruppo B Ia

Caratteristiche tecniche Technical characteristics	Norma Norms	Superficie Naturale	Superficie Strutturata
Resistenza all'abrasione profonda Abrasion resistance	ISO 10545-6	≤ 175 mm³	≤ 175 mm³
Resistenza allo scivolamento Slip resistance	EN 16165 (previously DIN 51130)	R9	R11
Resistenza allo scivolamento - Superfici bagnate a piedi scalzi Coefficient of friction - Dry surfaces walking on barefoot	EN 16165 (previously DIN 51097)	-	A+B+C
Resistenza allo scivolamento Dynamic coefficient of friction (DCOF)	ANSI A326.3	Conforme According to	Conforme According to
Coefficiente di attrito dinamico Dynamic friction coefficient	METODO B.C.R.A.	Conforme According to	Conforme According to
Grado di variazione cromatica Colour shade variation	V1 min - V4 max		V4

AVVERTENZE PER LA POSA - Gres porcellanato

RECOMMENDATIONS FOR INSTALLATION - Porcelain tile

Per la posa del materiale rettificato si prescrive una fuga minima di 2 mm.

As for rectified materials, a minimum joint of 2 mm is required.

Pour la pose du matériau rectifié, il faut réaliser un joint minimum de 2 mm.

Für die Verlegung des geschliffenen Materials ist eine Mindestfuge von 2 mm vorgeschrieben.

Si raccomanda di posare i materiali sfalsati di 20 cm al massimo, mai a metà della loro lunghezza

It is strongly recommended to install the materials in a staggered pattern of a maximum of 20 cm, never at half way its length.

Il est conseillé de poser les matériaux en décalé de 20 cm au maximum, jamais à la moitié de leur longueur.

Es wird empfohlen, die Materialien um höchstens 20 cm versetzt zu verlegen und nie in der Mitte ihrer Länge.

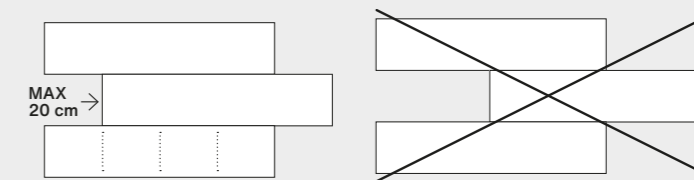

Per maggiori dettagli e aggiornamenti sulle certificazioni, consultare il nostro sito www.supergres.com
 For further details and updated information on certifications, please visit our website www.supergres.com
 Pour obtenir plus d'informations et de mises à jour sur les certifications, veuillez consulter notre site www.supergres.com
 Für weitere Details und Aktualisierungen der Zertifizierungen besuchen Sie bitte unsere Internetseite www.supergres.com

* Gamma completa Travel T20 a pagina 302 / For the complete range Travel T20 go to page 302

Walk



WALK

GRES PORCELLANATO | PORCELAIN TILE | GRÈS CÉRAMÉ | FEINSTEINZEUG
EN 14411 Allegato G . Piastrelle di ceramica pressate a secco con basso assorbimento d'acqua (E ≤ 0,5%) | Gruppo B la



22,5x45,3
R11 A+B+C
± 9 mm



22,5x22,5
R11 A+B+C
± 9 mm

SUPERFICIE STRUTTURATA | STRUCTURED SURFACE FINISH | FINITION STRUCTURÉE | STRUKTURIERTE OBERFLÄCHE



60x90 RT
R11 A+B+C
± 20 mm

Page n. 306

WALK



Street 22.5x45.3 . 9"x18"



Avenue
22.5x22.5 . 9"x9"
22.5x45.3 - 9"x18"



Way 22.5x45.3 . 9"x18"
Way Term. Elle 15x30 . 6"x12"
Way T_20 60x90 RT . 24"x36"

WALK

GRES PORCELLANATO | PORCELAIN TILE | GRÈS CÉRAMÉ | FEINSTEINZEUG

AVENUE



FINITURA STRUTTURATA R11 A+B+C		
WA45	22,5x45,3 - 9"x18"	± 9 mm
WA22	22,5x22,5 - 9"x9"	± 9 mm
FINITURA STRUTTURATA R11 A+B+C * T-20		
WAV9	60x90 RT - 24"x36"	± 20 mm

WAY



FINITURA STRUTTURATA R11 A+B+C		
WW45	22,5x45,3 - 9"x18"	± 9 mm
WW22	22,5x22,5 - 9"x9"	± 9 mm
FINITURA STRUTTURATA R11 A+B+C * T-20		
WWA9	60x90 RT - 24"x36"	± 20 mm

STREET



FINITURA STRUTTURATA R11 A+B+C		
WS45	22,5x45,3 - 9"x18"	± 9 mm
FINITURA STRUTTURATA R11 A+B+C * T-20		
WST9	60x90 RT - 24"x36"	± 20 mm

Pezzi speciali

SPECIAL TILES | PIÈCES SPÉCIALES | FORMTEILE

	AVENUE	WAY	STREET
Terminale a Elle TD Strutturato 15x30x4 h.	TLWA	TLWW	TLWS
Battiscopa TD 7x45,3*	YWAB	YWWB	YWSB

Imballi

EMBALLAGE | VERPACKUNG | PACKING

WALK

GRES PORCELLANATO | PORCELAIN TILE | GRÈS CÉRAMÉ | FEINSTEINZEUG

FORMATO	PZ/BOX	MQ/BOX	KG/BOX	BOX/PLT	MQ/PLT	KG/PLT	SPESSORE
22,5x22,5	20	1,01	19,40	42	42,52	829	9 mm
22,5x45,3	12	1,22	23,70	34	41,58	820	9 mm
15x30x4 h. terminale ad elle TD	8	0,36	10,75	48	17,28	530	-
7x45,3 battiscopa *	10	4,53 ml	6,80	98	443,94 ml	680	-
60x90 RT	2	1,08	48,00	24	25,92	1167	20 mm

* disponibile su tutti i colori, su ordinazione /available in all colors, to order

GRES PORCELLANATO | PORCELAIN TILE | GRÈS CÉRAMÉ | FEINSTEINZEUG

EN 14411 Allegato G . Piastrelle di ceramica pressate a secco con basso assorbimento d'acqua (E ≤ 0,5%)

Gruppo B la

Caratteristiche tecniche Technical characteristics	Norma Norms	Superficie Strutturata
Resistenza all'abrasione profonda Abrasion resistance	ISO 10545-6	≤ 175 mm ³
Resistenza allo scivolamento Slip resistance	EN 16165 (previously DIN 51130)	R11
Resistenza allo scivolamento - Superfici bagnate a piedi scalzi Coefficient of friction - Dry surfaces walking on barefoot	EN 16165 (previously DIN 51097)	A+B+C
Resistenza allo scivolamento Dynamic coefficient of friction (DCOF)	ANSI A326.3	Conforme According to
Coefficiente di attrito dinamico Dynamic friction coefficient	METODO B.C.R.A.	Conforme According to
Grado di variazione cromatica Colour shade variation	V1 min - V4 max	Way V3 - Street V4 Avenue V4

AVVERTENZE PER LA POSA - Gres porcellanato RECOMMENDATIONS FOR INSTALLATION - Porcelain tile

I formati 22.5x22.5 e 22.5x45.3 sono studiati per consentire pose modulari: a parità di calibro, si consiglia una fuga di 3 mm.

22.5x22.5 and 22.5x45.3 allows modular layouts, leaving a 3mm joint.

La modularité est assurée dans le cas d'une installation avec un joint de 3 mm.

Die Zusammenstellbarkeit ist bei der Verlegung mit 3 mm breiter Fuge.

* Gamma completa Walk T20 a pagina 306 / For the complete range Walk T20 go to page 306

Your match



Pearl 120x120 RT - 48"x48"

YOUR MATCH / FLOOR

GRES PORCELLANATO | PORCELAIN TILE | GRÈS CÉRAME | FEINSTEINZEUG
 EN 14411 Allegato G . Piastrelle di ceramica pressate a secco con basso assorbimento d'acqua (E ≤ 0,5%) | Gruppo B la

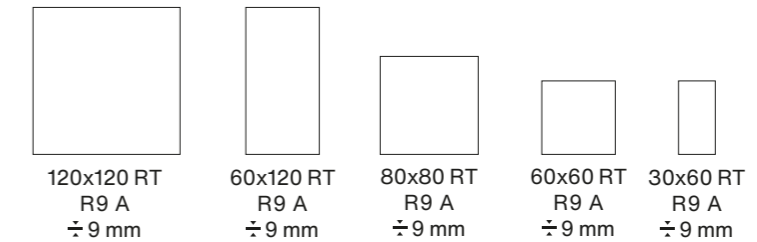

SUPERFICIE NATURALE | NATURAL SURFACE FINISH | SURFACE NATURELLE | NATÜRLICHE OBERFLÄCHE

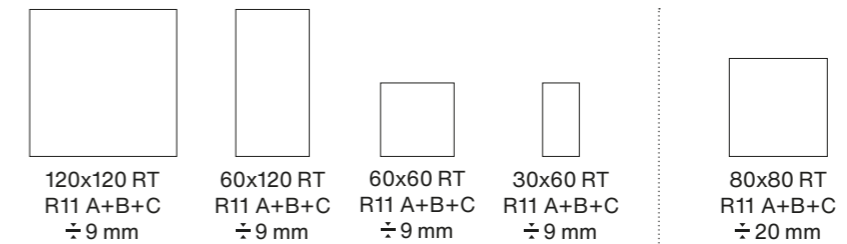

SUPERFICIE GRIP | SURFACE GRIP | SURFACE GRIP | OBERFLÄCHE GRIP

T20 Page n. 310

YOUR MATCH / WALL

RIVESTIMENTO IN PASTA BIANCA | WHITE BODY WALL TILES | REVÊTEMENTS EN PÂTE BLANCHE | WEISBSCHERBIGER WANDFLIESEN
 EN 14411 Allegato L . Piastrelle di ceramica pressate a secco (E >10%) | Gruppo BIII

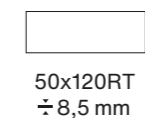
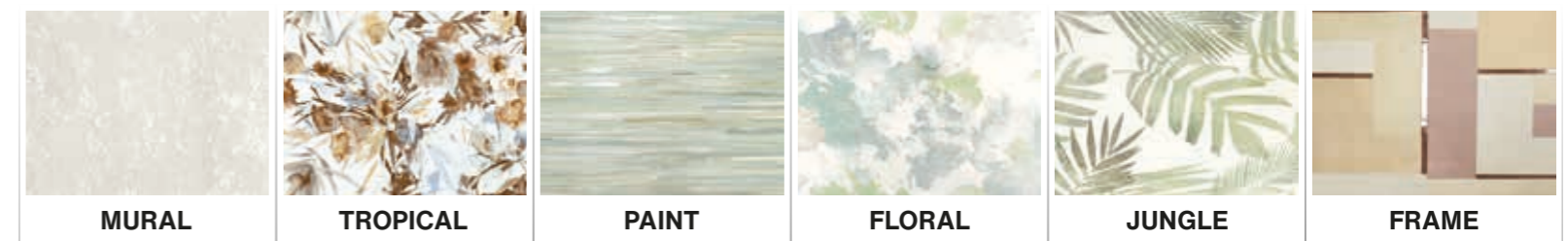
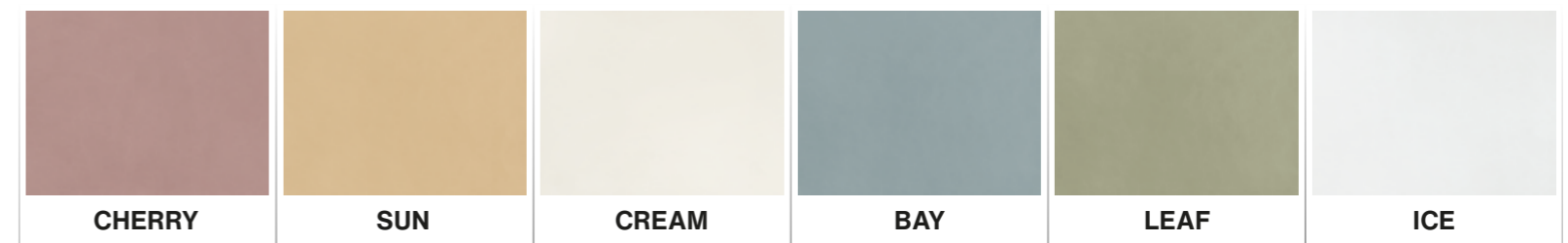

SUPERFICIE SATINATA | SATIN SURFACE FINISH | SURFACE SATINÉE | SATINIERTER OBERFLÄCHE

YOUR MATCH

RIVESTIMENTO
Mint 120x120 RT . 48"x48"

PAVIMENTO
Mint 30x60 RT . 12"x24"
Pearl 60x120RT . 24"x48"



YOUR MATCH

RIVESTIMENTO
Sun 50x120 RT . 20"x48"
Frame 50x120 RT . 20"x48"
Profilo Metallo Glitter / Bordeaux 1x100 . 0.4"x40"

PAVIMENTO
Clay 120x120 RT - 48"x48"



RIVESTIMENTO
Leaf 50x120 RT . 20"x48"
Jungle 50x120 RT . 20"x48"
Mosaico pad Green 30x30 RT . 12"x12"

PAVIMENTO
Tan 120x120 RT . 48"x48"



RIVESTIMENTO
Bay 50x120 RT . 20"x48"
Floral 50x120 RT . 20"x48"

PAVIMENTO
Collection Colovers: Love White 120x120 RT . 48"x48"



YOUR MATCH / FLOOR

GRES PORCELLANATO | PORCELAIN TILE | GRÈS CÉRAMÉ | FEINSTEINZEUG

PEARL



FINITURA NATURALE R9			
MGR1	120x120 RT - 48"x48"		± 9 mm
MPE6	60x120 RT - 24"x48"		± 9 mm
MPE8	80x80 RT - 32"x32"		± 9 mm
MPE0	60x60 RT - 24"x24"		± 9 mm
MPE3	30x60 RT - 12"x24"		± 9 mm
FINITURA GRIP R11 A+B+C			
MPLG	120x120 RT - 48"x48"		± 9 mm
PHG6	60x120 RT - 24"x48"		± 9 mm
M6PG	60x60 RT - 24"x24"		± 9 mm
PE3G	30x60 RT - 12"x24"		± 9 mm
FINITURA STRUTTURATA R11 A+B+C * T20			
MPT8	80x80 RT - 32"x32" T20		± 20 mm
MOSAICI			
MPMS	mosaico 30x30RT - 12"x12"		± 9 mm



Mosaico

FORMATO TESSERA
MOSAIC SIZE
4,8x4,8 - 2"x2"

MINT



FINITURA NATURALE R9			
MMN1	120x120 RT - 48"x48"		± 9 mm
MMT6	60x120 RT - 24"x48"		± 9 mm
MMN0	60x60 RT - 24"x24"		± 9 mm
MNT3	30x60 RT - 12"x24"		± 9 mm
MOSAICI			
MMNM	mosaico 30x30RT - 12"x12"		± 9 mm



Mosaico

FORMATO TESSERA
MOSAIC SIZE
4,8x4,8 - 2"x2"

DARK

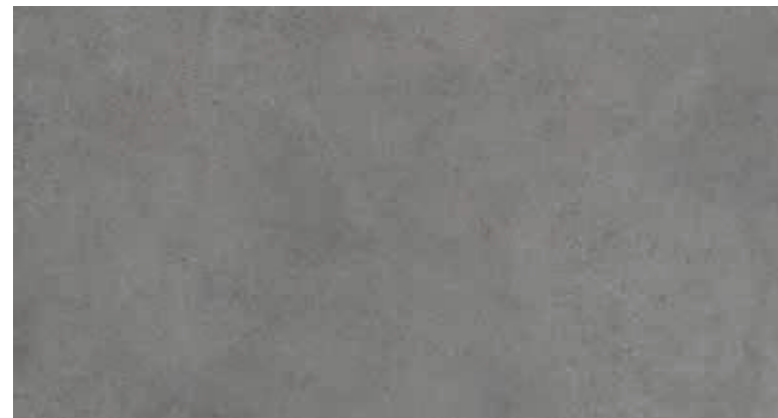

FINITURA NATURALE R9			
MDK1	120x120 RT - 48"x48"		± 9 mm
MDK6	60x120 RT - 24"x48"		± 9 mm
MDK8	80x80 RT - 32"x32"		± 9 mm
MDK0	60x60 RT - 24"x24"		± 9 mm
MDK3	30x60 RT - 12"x24"		± 9 mm
FINITURA STRUTTURATA R11 A+B+C * T20			
MDKT	80x80 RT - 32"x32" T20		± 20 mm
MOSAICI			
MDKM	mosaico 30x30RT - 12"x12"		± 9 mm



Mosaico

FORMATO TESSERA
MOSAIC SIZE
4,8x4,8 - 2"x2"

TAN



FINITURA NATURALE R9			
MTN1	120x120 RT - 48"x48"		± 9 mm
MTN6	60x120 RT - 24"x48"		± 9 mm
MNT8	80x80 RT - 32"x32"		± 9 mm
MTN0	60x60 RT - 24"x24"		± 9 mm
TN3M	30x60 RT - 12"x24"		± 9 mm
FINITURA GRIP R11 A+B+C			
MTNG	120x120 RT - 48"x48"		± 9 mm
MTA6	60x120 RT - 24"x48"		± 9 mm
TANG	60x60 RT - 24"x24"		± 9 mm
TN3G	30x60 RT - 12"x24"		± 9 mm
FINITURA STRUTTURATA R11 A+B+C * T20			
MTNT	80x80 RT - 32"x32" T20		± 20 mm
MOSAICI			
MTNM	mosaico 30x30RT - 12"x12"		± 9 mm



Mosaico

FORMATO TESSERA
MOSAIC SIZE
4,8x4,8 - 2"x2"

FOG



FINITURA NATURALE R9			
MFO1	120x120 RT - 48"x48"		± 9 mm
MFO6	60x120 RT - 24"x48"		± 9 mm
MFG8	80x80 RT - 32"x32"		± 9 mm
MFO0	60x60 RT - 24"x24"		± 9 mm
MFO3	30x60 RT - 12"x24"		± 9 mm
FINITURA GRIP R11 A+B+C			
MFGG	120x120 RT - 48"x48"		± 9 mm
FGO6	60x120 RT - 24"x48"		± 9 mm
MOGG	60x60 RT - 24"x24"		± 9 mm
MF3G	30x60 RT - 12"x24"		± 9 mm
FINITURA STRUTTURATA R11 A+B+C * T20			
MFGT	80x80 RT - 32"x32" T20		± 20 mm
MOSAICI			
MFGM	mosaico 30x30RT - 12"x12"		± 9 mm



Mosaico

FORMATO TESSERA
MOSAIC SIZE
4,8x4,8 - 2"x2"

CLAY



FINITURA NATURALE R9			
MCL1	120x120 RT - 48"x48"		± 9 mm
MCL6	60x120 RT - 24"x48"		± 9 mm
MCL8	80x80 RT - 32"x32"		± 9 mm
MCL0	60x60 RT - 24"x24"		± 9 mm
MCY3	30x60 RT - 12"x24"		± 9 mm
FINITURA GRIP R11 A+B+C			
MCLG	120x120 RT - 48"x48"		± 9 mm
MLG6	60x120 RT - 24"x48"		± 9 mm
ML6G	60x60 RT - 24"x24"		± 9 mm
MC3G	30x60 RT - 12"x24"		± 9 mm
MOSAICI			
MCLM	mosaico 30x30RT - 12"x12"		± 9 mm



Mosaico

FORMATO TESSERA
MOSAIC SIZE
4,8x4,8 - 2"x2"

* Gamma completa Your Match T20 a pagina 310 / For the complete range Your Match T20 go to page 310

YOUR MATCH / WALL

RIVESTIMENTO IN PASTA BIANCA | WHITE BODY WALL TILES | REVÊTEMENTS EN PÂTE BLANCHE | WEISBSCHERBIGER WANDFLIESEN

BAY



MBY5 - 50x120 RT - 20"x48" - ± 8,5 mm

SUN



MSU5 - 50x120 RT - 20"x48" - ± 8,5 mm

LEAF



MLE5 - 50x120 RT - 20"x48" - ± 8,5 mm

CHERRY



MCH5 - 50x120 RT - 20"x48" - ± 8,5 mm

ICE



MIC5 - 50x120 RT - 20"x48" - ± 8,5 mm

CREAM



MCR5 - 50x120 RT - 20"x48" - ± 8,5 mm

MURAL



MMU5 - 50x120 RT - 20"x48" - ± 8,5 mm

TROPICAL



MTR5 - 50x120 RT - 20"x48" - ± 8,5 mm

PAINT



MPN5 - 50x120 RT - 20"x48" - ± 8,5 mm

ICE . STRUTTURA LINE

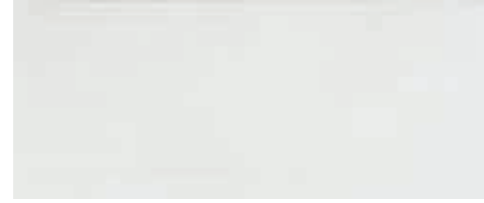

MISL - 50x120 RT - 20"x48" - ± 8,5 mm

CREAM . STRUTTURA LINE



MCRL - 50x120 RT - 20"x48" - ± 8,5 mm

FLORAL



MFL5 - 50x120 RT - 20"x48" - ± 8,5 mm

JUNGLE



MJU5 - 50x120 RT - 20"x48" - ± 8,5 mm

FRAME



MFM5 - 50x120 RT - 20"x48" - ± 8,5 mm

MOSAICO IN GRES PORCELLANATO | PORCELAIN TILE MOSAIC | MOSAIQUE EN GRÈS CÉRAME | FEINSTEINZEUG MOSAIK



MOSAICO PAD BLUE



MOSAICO PAD YELLOW



MOSAICO PAD GREEN



MOSAICO PAD BORDEAUX



MOSAICO PAD PEARL



MOSAICO PAD IVORY

MOSAICI			
PMGN	Mosaico PAD Green - 30x30 RT - 12"x12"	± 9 mm	
PMSB	Mosaico PAD Blue - 30x30 RT - 12"x12"	± 9 mm	
PMPE	Mosaico PAD Pearl - 30x30 RT - 12"x12"	± 9 mm	
PMSY	Mosaico PAD Yellow - 30x30 RT - 12"x12"	± 9 mm	
PMBX	Mosaico PAD Bordeaux - 30x30 RT - 12"x12"	± 9 mm	
PMIV	Mosaico PAD Ivory - 30x30 RT - 12"x12"	± 9 mm	

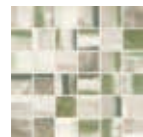

MOSAICO SHADE COLD

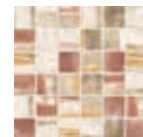

MOSAICO SHADE WARM

MOSAICI			
MSHC	Mosaico SHADE Cold - 30x30 RT - 12"x12"	± 9 mm	
MSHW	Mosaico SHADE Warm - 30x30 RT - 12"x12"	± 9 mm	

FORMATO TESSERA
MOSAIC SIZE
4,8x4,8 - 2"x2"

PMGB profilo metallo / glitter blue 1x100 RT - 0,4"x40"

PMGX profilo metallo / glitter bordeaux 1x100 RT - 0,4"x40"

Profili in metallo abbinabili a pag. 251
Metal profiles page 251

PMGR profilo metallo / glitter green 1x100 RT - 0,4"x40"

PMGY profilo metallo / glitter yellow 1x100 RT - 0,4"x40"

PAVIMENTI COORDINABILI IN GRES PORCELLANATO | COORDINATE FLOORS TILES PORCELAIN STONWARE
SOL COORDONNÉ EN GRÈS CÉRAME | KOODINIERTE BODENFLIESEN FEINSTEINZEUG

	BAY	LEAF	ICE	SUN	CHERRY	CREAM
YOUR MATCH (pag. 228)						
NATURAL APPEAL (pag. 148)						
PURITY OF MARBLE (pag. 164)						

YOUR MATCH

GRES PORCELLANATO | PORCELAIN TILE | GRÈS CÉRAME | FEINSTEINZEUG

Pezzi speciali

SPECIAL TILES | PIÈCES SPÉCIALES | FORMTEILE

Pezzi speciali disponibili su tutti i colori, su ordinazione.

Trim tiles available in all colors to order.

Pièces spéciales disponibles dans toutes les couleurs, sur demande.

Formteile auf Bestellung in allen Farben verfügbar.

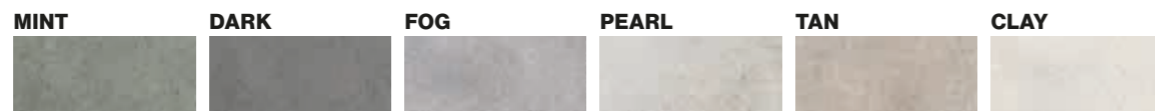
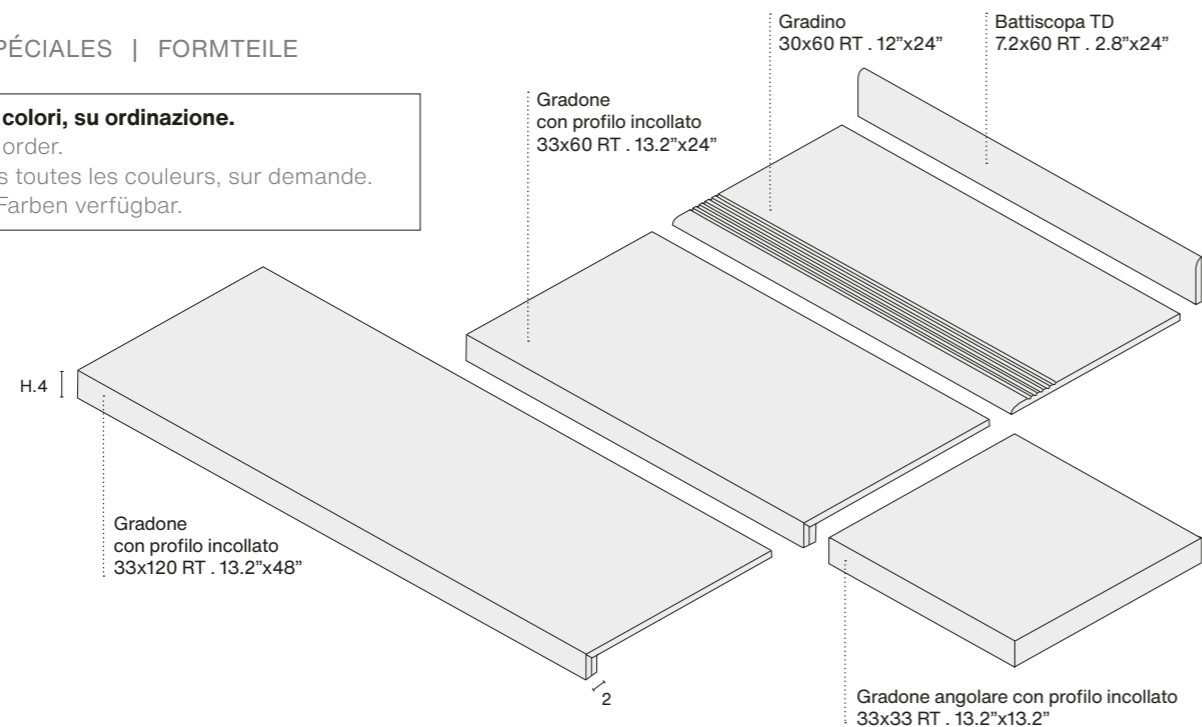

	MINT	DARK	FOG	PEARL	TAN	CLAY
Gradone c/prof. incollato 33x120 RT	MMNG	MDG3	FGG3	PLG3	MNG3	MCG3
Gradone c/prof. incollato 33x60 RT	MNG6	MKG6	FGG6	MPG6	TAG6	MCG6
Gradone c/prof. incollato 33x80 RT	-	MKG8	FGG8	MPG8	TNG8	MCG8
Ang. Gradone c/prof. inc. 33x33 RT	MN33	MD33	FG33	MP33	MT33	MC33
Gradino 30x60 RT	MMNR	MKGR	MFGR	MPGR	MTGR	MLGR
Battiscopa TD 7,2x80	-	MKB8	MOB8	MPB8	MTB8	CYB8
Battiscopa TD 7,2x60	MNB6	MDB6	FGB6	MPB6	TNB6	MCB6

GRES PORCELLANATO | PORCELAIN TILE | GRÈS CÉRAME | FEINSTEINZEUG

EN 14411 Allegato G . Piastrelle di ceramica pressate a secco con basso assorbimento d'acqua (E ≤ 0,5%)

Gruppo B la

Caratteristiche tecniche Technical characteristics	Norma Norms	Superficie Naturale	Superficie Grip
Resistenza all'abrasione profonda Abrasion resistance	ISO 10545-6	≤ 175 mm ³	≤ 175 mm ³
Resistenza allo scivolamento Slip resistance	EN 16165 (previously DIN 51130)	R9	R11
Resistenza allo scivolamento - Superfici bagnate a piedi scalzi Coefficient of friction - Dry surfaces walking on barefoot	EN 16165 (previously DIN 51097)	A	A+B+C
Resistenza allo scivolamento Dynamic coefficient of friction (DCOF)	ANSI A326.3	Conforme According to	Conforme According to
Coefficiente di attrito dinamico Dynamic friction coefficient	METODO B.C.R.A.	Conforme According to	Conforme According to
	Consultare il sito: Pour plus d'informations consulter:	www.supergres.com/upec	
Grado di variazione cromatica Colour shade variation	V1 min - V4 max	V3	

Imballi

EMBALLAGE | VERPACKUNG | PACKING

YOUR MATCH / FLOOR

GRES PORCELLANATO | PORCELAIN TILE | GRÈS CÉRAME | FEINSTEINZEUG

	PZ/BOX	MQ/BOX	KG/BOX	BOX/PLT	MQ/PLT	KG/PLT	SPESSORE
120x120 RT / 120x120 RT grip	2	2,88	60,00	20	57,60	1212	9 mm
60x120 RT / 60x120 RT grip	2	1,44	30,00	35	50,40	1062	9 mm
80x80 RT	2	1,28	25,50	48	61,44	1236	9 mm
60x60 RT / 60x60 RT grip	3	1,08	22,00	40	43,20	892	9 mm
30x60 RT / 30x60 RT grip	7	1,26	25,00	40	50,40	1012	9 mm
mosaico su rete 30x30RT	10	0,90	16,00	30	27,00	495	9 mm
battiscopa TD 7,2x60	10	6,00 ml	9,40	70	420 ml	673	-
battiscopa TD 7,2x80	8	6,40 ml	7,00	72	460,80 ml	519	-
gradino 30x60	7	-	-	-	-	-	-
gradone c/prof.incollato 33x120	2	-	-	-	-	-	-
gradone c/prof.incollato 33x80	2	-	-	-	-	-	-
gradone c/prof.incollato 33x60	4	-	-	-	-	-	-
ang/grad c/prof.inc. 33x33	4	-	-	-	-	-	-

YOUR MATCH / WALL

RIVESTIMENTO IN PASTA BIANCA | WHITE BODY WALL TILES | REVÊTEMENTS EN PÂTE BLANCHE | WEISßSCHERBIGER WANDFLIESEN

	PZ/BOX	MQ/BOX	KG/BOX	BOX/PLT	MQ/PLT	KG/PLT	SPESSORE
50x120RT	3	1,80	26,50	35	63,00	940	8,5 mm
50x120RT struttura	3	1,80	26,50	30	54,00	807	8,5 mm*
30x30 mosaico pad	6	0,54	9,00	48	25,92	447	9 mm
30x30 mosaico shade	6	0,54	9,00	48	25,92	447	9 mm
profilo metallo/glitter 1x100	3	-	-	-	-	-	8 mm

* Spessore riferito al fondo liscio equivalente . Thickness refers to the equivalent smooth background
Épaisseur se rapportant au carreau lisse équivalent . Die Stärke bezieht sich auf die entsprechende glatte Grundfliese

AVVERTENZE PER LA POSA - Gres porcellanato

RECOMMENDATIONS FOR INSTALLATION - Porcelain tile

Per la posa del materiale rettificato si prescrive una fuga minima di 2 mm.

As for rectified materials, a minimum joint of 2 mm is required.

Pour la pose du matériau rectifié, il faut réaliser un joint minimum de 2 mm.

Für die Verlegung des geschliffenen Materials ist eine Mindestfuge von 2 mm vorgeschrieben.

Si raccomanda di posare i materiali sfalsati di 20 cm al massimo, mai a metà della loro lunghezza

It is strongly recommended to install the materials in a staggered pattern of a maximum of 20 cm, never at half way its length.

Il est conseillé de poser les matériaux en décalé de 20 cm au maximum, jamais à la moitié de leur longueur.

Es wird empfohlen, die Materialien um höchstens 20 cm versetzt zu verlegen und nie in der Mitte ihrer Länge.

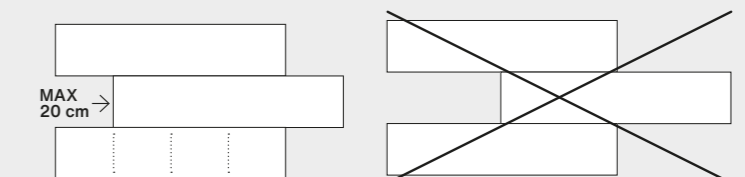

Per maggiori dettagli e aggiornamenti sulle certificazioni, consultare il nostro sito www.supergres.com
For further details and updated information on certifications, please visit our website www.supergres.com
Pour obtenir plus d'informations et de mises à jour sur les certifications, veuillez consulter notre site www.supergres.com
Für weitere Details und Aktualisierungen der Zertifizierungen besuchen Sie bitte unsere Internetseite www.supergres.com

Your match Palette N°2



RIVESTIMENTO
Coffee 50x120 RT . 20"x48"
Dream 50x120 RT . 20"x48"

PAVIMENTO
Dark 120x120 RT . 48"x48"
Collection Your Match

YOUR MATCH PALETTE N°2 / WALL

RIVESTIMENTO IN PASTA BIANCA | WHITE BODY WALL TILES | REVÊTEMENTS EN PÂTE BLANCHE | WEISBSCHERBIGER WANDFLIESEN
EN 14411 Allegato L . Piastrelle di ceramica pressate a secco (E >10%) | Gruppo Bill



50x120RT
± 8,5 mm

SUPERFICIE SATINATA | SATIN SURFACE FINISH | SURFACE SATINÉE | SATINIERTE OBERFLÄCHE

YOUR MATCH PALETTE N°2



YOUR MATCH PALETTE N°2 / WALL

RIVESTIMENTO IN PASTA BIANCA | WHITE BODY WALL TILES | REVÊTEMENTS EN PÂTE BLANCHE | WEISßSCHERBIGER WANDFLIESEN

DESERT



MDS5 - 50x120 RT - 20"x48" - ± 8,5 mm

RAIN



MRN5 - 50x120 RT - 20"x48" - ± 8,5 mm

ALOE



MAL5 - 50x120 RT - 20"x48" - ± 8,5 mm

COFFEE



MCF5 - 50x120 RT - 20"x48" - ± 8,5 mm

SKY

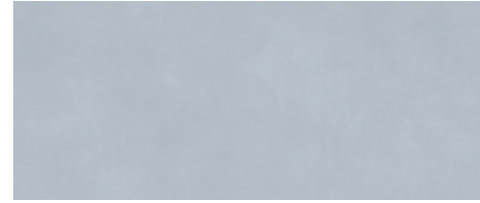

MSK5 - 50x120 RT - 20"x48" - ± 8,5 mm

DREAM



MDR5 - 50x120 RT - 20"x48" - ± 8,5 mm

GARDEN



MGA5 - 50x120 RT - 20"x48" - ± 8,5 mm

EDEN



MED5 - 50x120 RT - 20"x48" - ± 8,5 mm

PALM



MPM5 - 50x120 RT - 20"x48" - ± 8,5 mm

MOSAICO IN GRES PORCELLANATO | PORCELAIN TILE MOSAIC | MOSAIQUE EN GRÈS CÉRAME | FEINSTEINZEUG MOSAIK



MOSAICO PAD SAGE



MOSAICO PAD AIR



MOSAICO PAD GREY

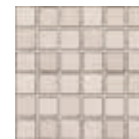

MOSAICO PAD BEIGE

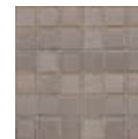

MOSAICO PAD BROWN

MOSAICI			
PMSG	Mosaico PAD Sage - 30x30 RT - 12"x12"	± 9 mm	
PMAL	Mosaico PAD Air - 30x30 RT - 12"x12"	± 9 mm	
PGYM	Mosaico PAD Grey - 30x30 RT - 12"x12"	± 9 mm	
PMBG	Mosaico PAD Beige - 30x30 RT - 12"x12"	± 9 mm	
PMBW	Mosaico PAD Brown - 30x30 RT - 12"x12"	± 9 mm	

FORMATO TESSERA
MOSAIC SIZE
4,8x4,8 - 2"x2"

PMGB profilo metallo / glitter blue 1x100 RT - 0,4"x40"

PMGX profilo metallo / glitter bordeaux 1x100 RT - 0,4"x40"

Profili in metallo abbinabili a pag. 251
Metal profiles page 251

PMGR profilo metallo / glitter green 1x100 RT - 0,4"x40"

PMGY profilo metallo / glitter yellow 1x100 RT - 0,4"x40"

DÉGRADÉ COLD



MDC2 - 50x120 RT - 20"x48" - ± 8,5 mm
Dégradé Cold comp. 2/pz

DÉGRADÉ WARM



MDW2 - 50x120 RT - 20"x48" - ± 8,5 mm
Dégradé Warm comp. 2/pz

Imballi

EMBALLAGE | VERPACKUNG | PACKING

YOUR MATCH PALETTE N°2 / WALL

RIVESTIMENTO IN PASTA BIANCA | WHITE BODY WALL TILES | REVÊTEMENTS EN PÂTE BLANCHE | WEISßSCHERBIGER WANDFLIESEN

	PZ/BOX	MQ/BOX	KG/BOX	BOX/PLT	MQ/PLT	KG/PLT	SPESSORE
50x120 RT	3	1,80	26,50	35	63,00	940	8,5 mm
dégradé 50x120 RT	1 comp.	1,20	18,00	-	-	-	8,5 mm
30x30 RT mosaico pad	6	0,54	9,00	48	25,92	476	9 mm
profilo metallo/glitter 1x100	3	-	-	-	-	-	8 mm

PAVIMENTI COORDINABILI IN GRES PORCELLANATO | COORDINATE FLOORS TILES PORCELAIN STONEWARE
SOL COORDONNÉ EN GRÈS CÉRAME | KOODINIERTE BODENFLIESEN FEINSTEINZEUG

	DESERT	COFFEE	RAIN	SKY	ALOE
YOUR MATCH (pag. 228)					
	MATCH TAN	MATCH CLAY	MATCH FOG	MATCH PEARL	MATCH MINT
COLOVERS (pag. 74)					
	LOVE BROWN	LOVE SAND	LOVE GREY	LOVE PEARL	LOVE WHITE
FREEDHOME (pag. 106)					
	TOBACCO	SAND	ECRU	HONEY	AMBER

Four Seasons



RIVESTIMENTO
Degradé A mosaico 30x30 - 12"x12"

FOUR SEASONS

MOSAICO IN GRES PORCELLANATO | PORCELAIN TILES MOSAIC | MOSAÏQUE EN GRÈS CÉRAME | FEINSTEINZEUG MOSAIK
EN 14411 Allegato G . Piastrelle di ceramica pressate a secco con basso assorbimento d'acqua (E ≤ 0,5%) | Gruppo B la

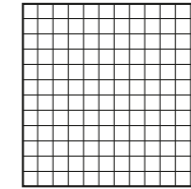

30x30 RT
± 8 mm

FORMATO TESSERA
MOSAIC SIZE
2,4x2,4 - 0.9"x0.9"

SUPERFICIE LUCIDA | GLOSSY SURFACE FINISH | SURFACE BRILLANTE | GLÄNZENDE OBERFLÄCHE

FOUR SEASONS

MOSAICO IN GRES PORCELLANATO | PORCELAIN TILES MOSAIC | MOSAIQUE EN GRÈS CÉRAME | FEINSTEINZEUG MOSAIK

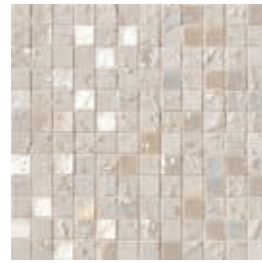

FSSP mosaico spring
30x30 - 12"x12" ± 8 mm



FSSN mosaico snow
30x30 - 12"x12" ± 8 mm

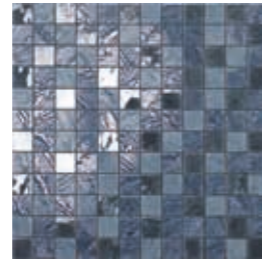

FSOC mosaico ocean
30x30 - 12"x12" ± 8 mm

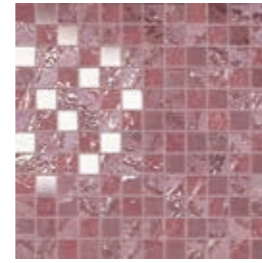

FSBL mosaico bloom
30x30 - 12"x12" ± 8 mm

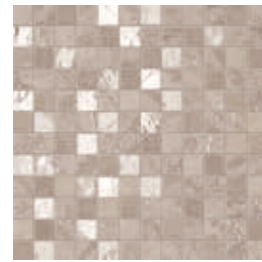

FSSA mosaico sand
30x30 - 12"x12" ± 8 mm

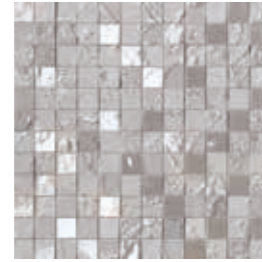

FSAU mosaico autumn
30x30 - 12"x12" ± 8 mm

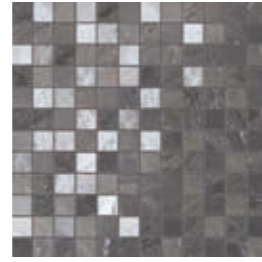

FSFO mosaico fog
30x30 - 12"x12" ± 8 mm

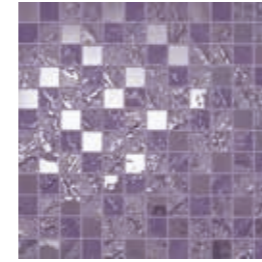

FSTU mosaico tulip
30x30 - 12"x12" ± 8 mm

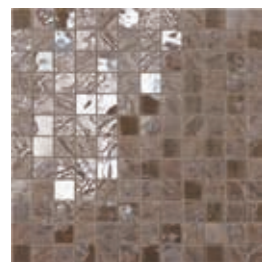

FSWO mosaico wood
30x30 - 12"x12" ± 8 mm

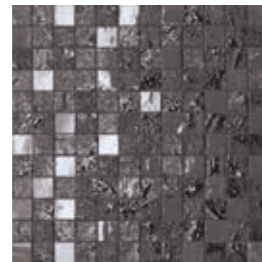

FSWI mosaico winter
30x30 - 12"x12" ± 8 mm



FSSU mosaico summer
30x30 - 12"x12" ± 8 mm



FSOA mosaico oasi
30x30 - 12"x12" ± 8 mm



FSFS mosaico four seasons
30x30 - 12"x12" ± 8 mm

FORMATO TESSERA
MOSAIC SIZE
2,4x2,4 - 0,9"x0,9"

PA5G profilo argento 1x50 - 0,6"x20" - ± 8 mm

PRAL prof. alluminio lucido 0,5x50 - 0,2"x20" - ± 8 mm

Prodotto non indicato per pavimenti soggetti ad usura
Product not suitable for floors subject to wear
Ce produit n'est pas indiqué pour les sols sujets à usure
Produkt nicht für Böden mit starker Abnutzung geeignet

Imballi

EMBALLAGE | VERPACKUNG | PACKING

	PZ/BOX	MQ/BOX	KG/BOX	BOX/PLT	MQ/PLT	KG/PLT	SPESSORE
Mosaico su rete	6	0,54	9,00	48	25,92	445	8 mm
Degradé C/6 pz.	1 comp.	0,54	9,00	-	-	-	8 mm
Profilo	6	-	-	-	-	-	8 mm

Per maggiori dettagli e aggiornamenti sulle certificazioni, consultare il nostro sito www.supergres.com
For further details and updated information on certifications, please visit our website www.supergres.com
Pour obtenir plus d'informations et de mises à jour sur les certifications, veuillez consulter notre site www.supergres.com
Für weitere Details und Aktualisierungen der Zertifizierungen besuchen Sie bitte unsere Internetseite www.supergres.com

MOSAICI E PROFILI ABBINABILI A TUTTE LE SERIE MOSAICS AND PROFILES TO MATCH ALL SERIES

MOSAICI IN GRES PORCELLANATO | PORCELAIN TILES MOSAICS



PMGN mosaico PAD green
30x30 - 12"x12" ± 8 mm



PMSB mosaico PAD blue
30x30 - 12"x12" ± 8 mm



PMPE mosaico PAD pearl
30x30 - 12"x12" ± 8 mm



PMSY mosaico PAD yellow
30x30 - 12"x12" ± 8 mm

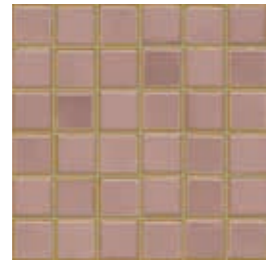

PMBX mosaico PAD bordeaux
30x30 - 12"x12" ± 8 mm

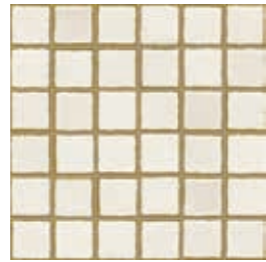

PMIV mosaico PAD ivory
30x30 - 12"x12" ± 8 mm



PMSG mosaico PAD sage
30x30 - 12"x12" ± 8 mm



PGYM mosaico PAD grey
30x30 - 12"x12" ± 8 mm



PMBG mosaico PAD beige
30x30 - 12"x12" ± 8 mm



PMBW mosaico PAD brown
30x30 - 12"x12" ± 8 mm



PMAI mosaico PAD air
30x30 - 12"x12" ± 8 mm



MHSC mosaico SHADE cold
30x30 - 12"x12" ± 8 mm

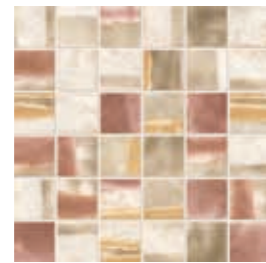

MSHW mosaico SHADE warm
30x30 - 12"x12" ± 8 mm

FORMATO TESSERA
MOSAIC SIZE
4,8x4,8 - 1,9"x1,9"



MEDB mos. esag. dec. bronze
34,5x29,8 - 12,6"x11,7" ± 9 mm



MEDS mos. esag. dec. steel
34,5x29,8 - 12,6"x11,7" ± 9 mm



MEKG mos. esag. dec. grey
34,5x29,8 - 12,6"x11,7" ± 9 mm



MEKS mos. esag. dec. sand
34,5x29,8 - 12,6"x11,7" ± 9 mm

PROFILI IN METALLO | METAL PROFILES



PMGY profilo metallo / glitter yellow 1x100 RT - 0,4"x40"



PMGB profilo metallo / glitter blue 1x100 RT - 0,4"x40"

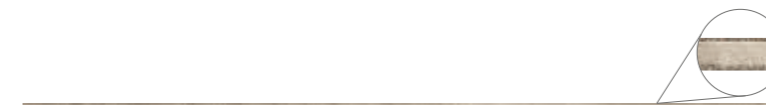

PMGG profilo metallo glitter gold 1x100 RT - 0,4"x40"



PMGS profilo metallo glitter silver 1x100 RT - 0,4"x40"



PRKB profilo metallo raku bronze 1x100 RT - 0,4"x40"



PRKG profilo raku green 1x100 RT - 0,4"x40"



PMAR profilo metallo argento 0,5x100 RT - 0,2"x40"



PMRA profilo metallo rame 0,5x100 RT - 0,2"x40"



MPGB profilo glitter bronzo 0,5x75 - 0,2"x30"



MPGA profilo glitter argento 0,5x75 - 0,2"x30"



PMGR profilo metallo / glitter green 1x100 RT - 0,4"x40"



PMGX profilo metallo / glitter bordeaux 1x100 RT - 0,4"x40"



PMGi profilo metallo glitter iron 1x100 RT - 0,4"x40"



PFMC profilo metallo glitter copper 1x100 RT - 0,4"x40"



PRKD profilo raku dust 1x100 RT - 0,4"x40"



PRUK profilo raku dark 1x100 RT - 0,4"x40"

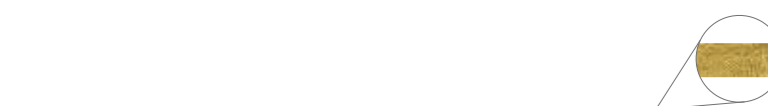

PMOR profilo metallo oro 0,5x100 RT - 0,2"x40"



PAG5 profilo argento 1,5x50 - 0,6"x20"



PRAL prof. alluminio lucido 0,5x50 - 0,2"x20"

Imballi

EMBALLAGE | VERPACKUNG | PACKING

	PZ/BOX	MQ/BOX	KG/BOX	BOX/PLT	MQ/PLT	KG/PLT	SPESSORE
Mosaico 30x30	6	0,54	9,00	48	25,92	445	9 mm
Mosaico Esagona Dek	6	0,62	11,50	42	25,91	495	9 mm
Profilo 1x100 / 0,5x100	3	-	-	-	-	-	8 mm
Profilo 0,5x75 / 0,5x50 / 1,5x50	6	-	-	-	-	-	8 mm



T_20

ADIGE T_20.....	254
ART T_20.....	258
ASTRUM T_20.....	262
EKHO T_20.....	266
FORTH T_20.....	270
FREEDHOME T_20.....	274
FRENCH MOOD T_20.....	278
H.24 T_20.....	282
OVERTIME T_20.....	286
STOCKHOLM T_20.....	290
STONEWORK T_20.....	294
STORY T_20.....	298
TRAVEL T_20.....	302
WALK T_20.....	306
YOUR MATCH T_20.....	310



Adige T_20



Bolzano T20 60x120 RT . 12"x24"
Bolzano T20 terminale elle 20x60 RT . 6"x12"

ADIGE T_20

GRES PORCELLANATO | PORCELAIN TILE | GRÈS CÉRAME | FEINSTEINZEUG
EN 14411 Allegato G . Piastrelle di ceramica pressate a secco con basso assorbimento d'acqua (E ≤ 0,5%) | Gruppo B la



60x120 RT
R11 A+B+C
÷ 20 mm



SUPERFICIE STRUTTURATA | STRUCTURED SURFACE FINISH | FINITION STRUCTURÉE | STRUKTURIERTE OBERFLÄCHE

ADIGE T_20

GRES PORCELLANATO | PORCELAIN TILE | GRÈS CÉRAME | FEINSTEINZEUG

TRENTO T_20



FINITURA STRUTTURATA R11 A+B+C		T_20
T12A	60x120 RT - 24"x48"	± 20 mm
PEZZI SPECIALI LATO 120		
TNAR	round 30x120 RT - 12"x48"	± 20 mm
TNAI	round ang. interno comp. 2/pz. 30x120 RT - 12"x48"	± 20 mm
TNAE	round ang. esterno comp. 2/pz. 30x120 RT - 12"x48"	± 20 mm
TNCL	costa lucida 30x120 RT - 12"x48"	± 20 mm
TCAI	ang. int. costa lucida comp. 2/pz. 30x120 RT - 12"x48"	± 20 mm
TCAE	ang. est. costa lucida comp. 2/pz. 30x120 RT - 12"x48"	± 20 mm
TNTL	terminale "elle" c/profilo incollato 20x120 RT - 8"x48"	± 20 mm

MERANO T_20



FINITURA STRUTTURATA R11 A+B+C		T_20
M12A	60x120 RT - 24"x48"	± 20 mm
PEZZI SPECIALI LATO 120		
MROR	round 30x120 RT - 12"x48"	± 20 mm
MRAI	round ang. interno comp. 2/pz. 30x120 RT - 12"x48"	± 20 mm
MOAE	round ang. esterno comp. 2/pz. 30x120 RT - 12"x48"	± 20 mm
MRCL	costa lucida 30x120 RT - 12"x48"	± 20 mm
CMAI	ang. int. costa lucida comp. 2/pz. 30x120 RT - 12"x48"	± 20 mm
RAEC	ang. est. costa lucida comp. 2/pz. 30x120 RT - 12"x48"	± 20 mm
RNTL	terminale "elle" c/profilo incollato 20x120 RT - 8"x48"	± 20 mm

BOLZANO T_20



FINITURA STRUTTURATA R11 A+B+C		T_20
B12A	60x120 RT - 24"x48"	± 20 mm
PEZZI SPECIALI LATO 120		
BZRR	round 30x120 RT - 12"x48"	± 20 mm
BZAI	round ang. interno comp. 2/pz. 30x120 RT - 12"x48"	± 20 mm
BZAE	round ang. esterno comp. 2/pz. 30x120 RT - 12"x48"	± 20 mm
BZCL	costa lucida 30x120 RT - 12"x48"	± 20 mm
BAIZ	ang. int. costa lucida comp. 2/pz. 30x120 RT - 12"x48"	± 20 mm
BAEZ	ang. est. costa lucida comp. 2/pz. 30x120 RT - 12"x48"	± 20 mm
BZTL	terminale "elle" c/profilo incollato 20x120 RT - 8"x48"	± 20 mm

Imballi

EMBALLAGE | VERPACKUNG | PACKING

ADIGE T_20

GRES PORCELLANATO | PORCELAIN TILE | GRÈS CÉRAME | FEINSTEINZEUG

	PZ/BOX	MQ/BOX	KG/BOX	BOX/PLT	MQ/PLT	KG/PLT	SPESSORE
60x120 RT	1	0,72	32,00	35	25,20	1135	20 mm
round	1	-	-	-	-	-	20 mm
round ang/int comp. 2 pz	1 comp.	-	-	-	-	-	20 mm
round ang/est comp. 2 pz	1 comp.	-	-	-	-	-	20 mm
term. ad "elle" c/prof. inc.	2	-	-	-	-	-	20 mm
costa lucida	1	-	-	-	-	-	20 mm
ang/int costa lucida comp. 2 pz	1 comp.	-	-	-	-	-	20 mm
ang/est costa lucida comp. 2 pz	1 comp.	-	-	-	-	-	20 mm
Accessori T_20	pag. 354						
Pezzi speciali T_20	pag. 356						

Avvertenze e ulteriori informazioni sulla posa dei pavimenti T20 a pag. 348 di questo catalogo

Further information on the installation of T20 floors on page 348 of this catalogue

Pour d'ultérieures informations sur la pose des planchers T20, consultez la page 348 de ce catalogue

Weitere Informationen über die Verlegung von T20 finden Sie auf Seite 348 in diesem Katalog.

GRES PORCELLANATO | PORCELAIN TILE | GRÈS CÉRAME | FEINSTEINZEUG

EN 14411 Allegato G . Piastrelle di ceramica pressate a secco con basso assorbimento d'acqua (E ≤ 0,5%)

Gruppo B la

Caratteristiche tecniche	Norma	Valore
Technical characteristics	Norms	Value
Resistenza all'abrasione profonda		
Abrasion resistance	ISO 10545-6	≤ 175 mm ³
Resistenza allo scivolamento		
Slip resistance	EN 16165 (previously DIN 51130)	R11
Resistenza allo scivolamento - Superfici bagnate a piedi scalzi		
Coefficient of friction - Dry surfaces walking on barefoot	EN 16165 (previously DIN 51097)	A+B+C
Resistenza allo scivolamento		
Dynamic coefficient of friction (DCOF)	ANSI A326.3	Conforme According to
Coefficiente di attrito dinamico		
Dynamic friction coefficient	METODO B.C.R.A.	Conforme According to
Grado di variazione cromatica		
Colour shade variation	V1 min - V4 max	V4

Per maggiori dettagli e aggiornamenti sulle certificazioni, consultare il nostro sito www.supergres.com
 For further details and updated information on certifications, please visit our website www.supergres.com
 Pour obtenir plus d'informations et de mises à jour sur les certifications, veuillez consulter notre site www.supergres.com
 Für weitere Details und Aktualisierungen der Zertifizierungen besuchen Sie bitte unsere Internetseite www.supergres.com

Art T_20



PAVIMENTO
 Art Cement T_20 60x60RT . 24"x24"
 Art Graphite T_20 60x60RT . 24"x24"
 Art Cement T_20 Term. "Elle" 20x60RT . 8"x24"

ART T_20

GRES PORCELLANATO | PORCELAIN TILE | GRÈS CÉRAME | FEINSTEINZEUG
 EN 14411 Allegato G . Piastrelle di ceramica pressate a secco con basso assorbimento d'acqua (E ≤ 0,5%) | Gruppo B la

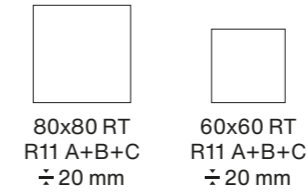
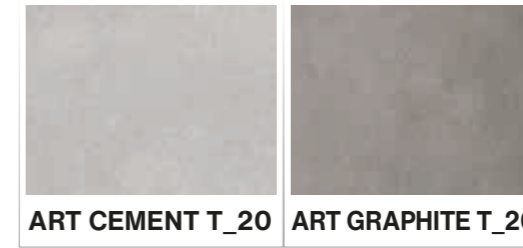

SUPERFICIE STRUTTURATA | STRUCTURED SURFACE FINISH | FINITION STRUCTURÉE | STRUKTURIERTE OBERFLÄCHE

ART T_20

GRES PORCELLANATO | PORCELAIN TILE | GRÈS CÉRAME | FEINSTEINZEUG

ART CEMENT T_20



FINITURA STRUTTURATA R11 A+B+C T_20		
CMA8	80x80 RT -32"x32"	± 20 mm
A2CE	60x60 RT - 24"x24"	± 20 mm
PEZZI SPECIALI LATO 60		
CTR6	round 30x60 RT - 12"x24"	± 20 mm
CAIR	round ang. interno comp. 2/pz. 30x60 RT - 12"x24"	± 20 mm
CAER	round ang. esterno comp. 2/pz. 30x60 RT - 12"x24"	± 20 mm
C2CL	costa lucida 30x60 RT - 12"x24"	± 20 mm
C2AI	ang. int. costa lucida comp. 2/pz. 30x60 RT - 12"x24"	± 20 mm
C2AE	ang. est. costa lucida comp. 2/pz. 30x60 RT - 12"x24"	± 20 mm
C2GR	griglia 20x60 RT - 8"x24"	± 20 mm
C2AG	angolare griglia comp. 2/pz. 20x60 RT - 8"x24"	± 20 mm
C2TL	terminale "elle" c/profilo incollato 20x60 RT - 8"x24"	± 20 mm
PEZZI SPECIALI LATO 80		
CMR8	round 40x80 RT - 16"x32"	± 20 mm
AIR8	round ang. interno comp. 2/pz. 40x80 RT - 16"x32"	± 20 mm
REA8	round ang. esterno comp. 2/pz. 40x80 RT - 16"x32"	± 20 mm
CLCM	costa lucida 40x80 RT - 16"x32"	± 20 mm
CAI8	ang. int. costa lucida comp. 2/pz. 40x80 RT - 16"x32"	± 20 mm
CEA8	ang. est. costa lucida comp. 2/pz. 40x80 RT - 16"x32"	± 20 mm
CML8	terminale "elle" c/profilo incollato 20x80 RT - 8"x32"	± 20 mm

ART GRAPHITE T_20



FINITURA STRUTTURATA R11 A+B+C T_20		
AGH8	80x80 RT -32"x32"	± 20 mm
AGR2	60x60 RT - 24"x24"	± 20 mm
PEZZI SPECIALI LATO 60		
GTR6	round 30x60 RT - 12"x24"	± 20 mm
GAIR	round ang. interno comp. 2/pz. 30x60 RT - 12"x24"	± 20 mm
GAER	round ang. esterno comp. 2/pz. 30x60 RT - 12"x24"	± 20 mm
G2CL	costa lucida 30x60 RT - 12"x24"	± 20 mm
G2AI	ang. int. costa lucida comp. 2/pz. 30x60 RT - 12"x24"	± 20 mm
G2AE	ang. est. costa lucida comp. 2/pz. 30x60 RT - 12"x24"	± 20 mm
G2GR	griglia 20x60 RT - 8"x24"	± 20 mm
G2AG	angolare griglia comp. 2/pz. 20x60 RT - 8"x24"	± 20 mm
GT2L	terminale "elle" c/profilo incollato 20x60 RT - 8"x24"	± 20 mm
PEZZI SPECIALI LATO 80		
RGH8	round 40x80 RT - 16"x32"	± 20 mm
GAI8	round ang. interno comp. 2/pz. 40x80 RT - 16"x32"	± 20 mm
GAE8	round ang. esterno comp. 2/pz. 40x80 RT - 16"x32"	± 20 mm
CLGH	costa lucida 40x80 RT - 16"x32"	± 20 mm
GIL8	ang. int. costa lucida comp. 2/pz. 40x80 RT - 16"x32"	± 20 mm
AEL8	ang. est. costa lucida comp. 2/pz. 40x80 RT - 16"x32"	± 20 mm
GAL8	terminale "elle" c/profilo incollato 20x80 RT - 8"x32"	± 20 mm

Imballi

EMBALLAGE | VERPACKUNG | PACKING

ART T_20

GRES PORCELLANATO | PORCELAIN TILE | GRÈS CÉRAME | FEINSTEINZEUG

	PZ/BOX	MQ/BOX	KG/BOX	BOX/PLT	MQ/PLT	KG/PLT	SPESSORE
80x80 RT	1	0,64	27,00	42	26,88	1146	20 mm
60x60 RT	2	0,72	32,00	30	21,60	972	20 mm
round	1	-	-	-	-	-	20 mm
round ang/int comp. 2 pz	1 comp.	-	-	-	-	-	20 mm
round ang/est comp. 2 pz	1 comp.	-	-	-	-	-	20 mm
term. ad "elle" c/prof. inc.	2	-	-	-	-	-	20 mm
griglia	1	-	-	-	-	-	20 mm
ang. griglia comp. 2 pz	1 comp.	-	-	-	-	-	20 mm
costa lucida	1	-	-	-	-	-	20 mm
ang/int costa lucida comp. 2 pz	1 comp.	-	-	-	-	-	20 mm
ang/est costa lucida comp. 2 pz	1 comp.	-	-	-	-	-	20 mm
Accessori T_20	pag. 354						
Pezzi speciali T_20	pag. 356						

Avvertenze e ulteriori informazioni sulla posa dei pavimenti T20 a pag. 348 di questo catalogo

Further information on the installation of T20 floors on page 348 of this catalogue

Pour d'ultérieures informations sur la pose des planchers T20, consultez la page 348 de ce catalogue

Weitere Informationen über die Verlegung von T20 finden Sie auf Seite 348 in diesem Katalog.

GRES PORCELLANATO | PORCELAIN TILE | GRÈS CÉRAME | FEINSTEINZEUG

EN 14411 Allegato G . Piastrelle di ceramica pressate a secco con basso assorbimento d'acqua (E ≤ 0,5%)

Gruppo B Ia

Caratteristiche tecniche	Norma	Valore
Technical characteristics	Norms	Value
Resistenza all'abrasione profonda		
Abrasion resistance	ISO 10545-6	≤ 175 mm ³
Resistenza allo scivolamento		
Slip resistance	EN 16165 (previously DIN 51130)	R11
Resistenza allo scivolamento - Superfici bagnate a piedi scalzi		
Coefficient of friction - Dry surfaces walking on barefoot	EN 16165 (previously DIN 51097)	A+B+C
Resistenza allo scivolamento		
Dynamic coefficient of friction (DCOF)	ANSI A326.3	Conforme According to
Coefficiente di attrito dinamico		
Dynamic friction coefficient	METODO B.C.R.A.	Conforme According to
	Consultare il sito: Pour plus d'informations consulter:	www.supergres.com/upec
Grado di variazione cromatica		
Colour shade variation	V1 min - V4 max	V3

Per maggiori dettagli e aggiornamenti sulle certificazioni, consultare il nostro sito www.supergres.com
 For further details and updated information on certifications, please visit our website www.supergres.com
 Pour obtenir plus d'informations et de mises à jour sur les certifications, veuillez consulter notre site www.supergres.com
 Für weitere Details und Aktualisierungen der Zertifizierungen besuchen Sie bitte unsere Internetseite www.supergres.com

Astrum T_20



Beige Cross Cut T_20 60x60RT . 24"x24"

ASTRUM T_20

GRES PORCELLANATO | PORCELAIN TILE | GRÈS CÉRAME | FEINSTEINZEUG
EN 14411 Allegato G . Piastrelle di ceramica pressate a secco con basso assorbimento d'acqua (E ≤ 0,5%) | Gruppo B la

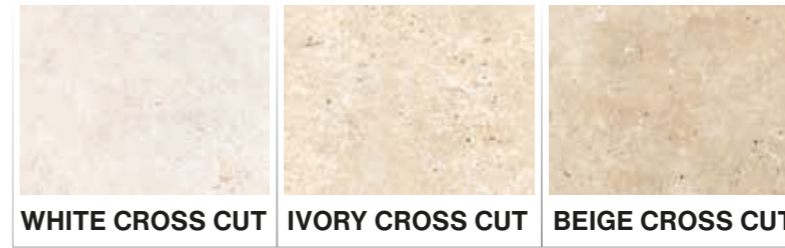

WHITE CROSS CUT | IVORY CROSS CUT | BEIGE CROSS CUT



60x120 RT
R11 A+B+C
± 20 mm



60x60 RT
R11 A+B+C
± 20 mm



SUPERFICIE STRUTTURATA | STRUCTURED SURFACE FINISH | FINITION STRUCTURÉE | STRUKTURIERTE OBERFLÄCHE

ASTRUM T_20

GRES PORCELLANATO | PORCELAIN TILE | GRÈS CÉRAMÉ | FEINSTEINZEUG

WHITE CROSS CUT T_20



FINITURA STRUTTURATA R11 A+B+C T_20	
WHT2	60x120 RT - 24"x48" T20 ± 20 mm
WHS6	60x60 RT - 24"x24" T20 ± 20 mm
PEZZI SPECIALI LATO 60	
WHRD	round 30x60 RT - 12"x24" ± 20 mm
HIRR	round ang. interno comp. 2/pz. 30x60 RT - 12"x24" ± 20 mm
HERR	round ang. esterno comp. 2/pz. 30x60 RT - 12"x24" ± 20 mm
SWCU	costa lucida 30x60 RT - 12"x24" ± 20 mm
WILC	ang. int. costa lucida comp. 2/pz. 30x60 RT - 12"x24" ± 20 mm
WELC	ang. est. costa lucida comp. 2/pz. 30x60 RT - 12"x24" ± 20 mm
SWG2	griglia 20x60 RT - 8"x24" ± 20 mm
BWAG	angolare griglia comp. 2/pz. 20x60 RT - 8"x24" ± 20 mm
SWHL	terminale "elle" c/profilo incollato 20x60 RT - 8"x24" ± 20 mm
PEZZI SPECIALI LATO 120	
WHR1	round 30x120 RT - 16"x32" ± 20 mm
RWAI	round ang. interno comp. 2/pz. 30x120 RT - 24"x48" ± 20 mm
RWAE	round ang. esterno comp. 2/pz. 30x120 RT - 24"x48" ± 20 mm
WHTC	costa lucida 30x120 RT - 16"x32" ± 20 mm
WIHL	ang. int. costa lucida comp. 2/pz. 30x120 RT - 16"x32" ± 20 mm
WEHL	ang. est. costa lucida comp. 2/pz. 30x120 RT - 16"x32" ± 20 mm
WHLT	terminale "elle" c/profilo incollato 20x120 RT - 8"x48" ± 20 mm

IVORY CROSS CUT T_20



FINITURA STRUTTURATA R11 A+B+C T_20	
AIV2	60x120 RT - 24"x48" T20 ± 20 mm
BIV6	60x60 RT - 24"x24" T20 ± 20 mm
PEZZI SPECIALI LATO 60	
SRD6	round 30x60 RT - 12"x24" ± 20 mm
VAIR	round ang. interno comp. 2/pz. 30x60 RT - 12"x24" ± 20 mm
VEER	round ang. esterno comp. 2/pz. 30x60 RT - 12"x24" ± 20 mm
IVCU	costa lucida 30x60 RT - 12"x24" ± 20 mm
IVIL	ang. int. costa lucida comp. 2/pz. 30x60 RT - 12"x24" ± 20 mm
IVEL	ang. est. costa lucida comp. 2/pz. 30x60 RT - 12"x24" ± 20 mm
SVG2	griglia 20x60 RT - 8"x24" ± 20 mm
VSAG	angolare griglia comp. 2/pz. 20x60 RT - 8"x24" ± 20 mm
VSLT	terminale "elle" c/profilo incollato 20x60 RT - 8"x24" ± 20 mm
PEZZI SPECIALI LATO 120	
AIR1	round 30x120 RT - 16"x32" ± 20 mm
IIAR	round ang. interno comp. 2/pz. 30x120 RT - 24"x48" ± 20 mm
EIAR	round ang. esterno comp. 2/pz. 60x120 RT - 24"x48" ± 20 mm
AITC	costa lucida 30x120 RT - 16"x32" ± 20 mm
ICLI	ang. int. costa lucida comp. 2/pz. 30x120 RT - 16"x32" ± 20 mm
ICLE	ang. est. costa lucida comp. 2/pz. 30x120 RT - 16"x32" ± 20 mm
IVTL	terminale "elle" c/profilo incollato 20x120 RT - 8"x48" ± 20 mm

BEIGE CROSS CUT T_20



FINITURA STRUTTURATA R11 A+B+C T_20	
ABG2	60x120 RT - 24"x48" T20 ± 20 mm
BAT6	60x60 RT - 24"x24" T20 ± 20 mm
PEZZI SPECIALI LATO 60	
BERD	round 30x60 RT - 12"x24" ± 20 mm
EIRR	round ang. interno comp. 2/pz. 30x60 RT - 12"x24" ± 20 mm
EIER	round ang. esterno comp. 2/pz. 30x60 RT - 12"x24" ± 20 mm
SBCU	costa lucida 30x60 RT - 12"x24" ± 20 mm
BGIL	ang. int. costa lucida comp. 2/pz. 30x60 RT - 12"x24" ± 20 mm
BGEL	ang. est. costa lucida comp. 2/pz. 30x60 RT - 12"x24" ± 20 mm
SBG2	griglia 20x60 RT - 8"x24" ± 20 mm
BSAG	angolare griglia comp. 2/pz. 20x60 RT - 8"x24" ± 20 mm
BSTL	terminale "elle" c/profilo incollato 20x60 RT - 8"x24" ± 20 mm
PEZZI SPECIALI LATO 120	
BAR1	round 30x120 RT - 16"x32" ± 20 mm
RBEI	round ang. interno comp. 2/pz. 30x120 RT - 24"x48" ± 20 mm
RBEE	round ang. esterno comp. 2/pz. 30x120 RT - 24"x48" ± 20 mm
BETC	costa lucida 30x120 RT - 16"x32" ± 20 mm
IBLE	ang. int. costa lucida comp. 2/pz. 30x120 RT - 16"x32" ± 20 mm
EBLE	ang. est. costa lucida comp. 2/pz. 30x120 RT - 16"x32" ± 20 mm
BELT	terminale "elle" c/profilo incollato 20x120 RT - 8"x48" ± 20 mm

Imballi

EMBALLAGE | VERPACKUNG | PACKING

ASTRUM T_20

GRES PORCELLANATO | PORCELAIN TILE | GRÈS CÉRAMÉ | FEINSTEINZEUG

	PZ/BOX	MQ/BOX	KG/BOX	BOX/PLT	MQ/PLT	KG/PLT	SPESSORE
60x120 RT	1	0,72	32,00	35	25,20	1135	20 mm
60x60 RT	2	0,72	32,00	30	21,60	972	20 mm
round	1	-	-	-	-	-	20 mm
round ang/int comp. 2 pz	1 comp.	-	-	-	-	-	20 mm
round ang/est comp. 2 pz	1 comp.	-	-	-	-	-	20 mm
costa lucida	1	-	-	-	-	-	20 mm
costa lucida ang/int. comp. 2 pz	1 comp.	-	-	-	-	-	20 mm
costa lucida ang/est. comp. 2 pz	1 comp.	-	-	-	-	-	20 mm
griglia	1	-	-	-	-	-	20 mm
ang. griglia comp. 2 pz	1 comp.	-	-	-	-	-	20 mm
term. ad "elle" c/prof. inc.	2	-	-	-	-	-	20 mm
Accessori T_20	pag. 354						
Pezzi speciali T_20	pag. 356						

Avvertenze e ulteriori informazioni sulla posa dei pavimenti T20 a pag. 348 di questo catalogo

Further information on the installation of T20 floors on page 348 of this catalogue

Pour d'ultérieures informations sur la pose des planchers T20, consultez la page 348 de ce catalogue

Weitere Informationen über die Verlegung von T20 finden Sie auf Seite 348 in diesem Katalog.

GRES PORCELLANATO | PORCELAIN TILE | GRÈS CÉRAMÉ | FEINSTEINZEUG

EN 14411 Allegato G . Piastrelle di ceramica pressate a secco con basso assorbimento d'acqua (E ≤ 0,5%)

Gruppo B Ia

Caratteristiche tecniche Technical characteristics	Norma Norms	Valore Value
Resistenza all'abrasione profonda Abrasion resistance	ISO 10545-6	≤ 175 mm ³
Resistenza allo scivolamento Slip resistance	EN 16165 (previously DIN 51130)	R11
Resistenza allo scivolamento - Superfici bagnate a piedi scalzi Coefficient of friction - Dry surfaces walking on barefoot	EN 16165 (previously DIN 51097)	A+B+C
Resistenza allo scivolamento Dynamic coefficient of friction (DCOF)	ANSI A326.3	Conforme According to
Coefficiente di attrito dinamico Dynamic friction coefficient	METODO B.C.R.A.	Conforme According to
Grado di variazione cromatica Colour shade variation	V1 min - V4 max	V3

Per maggiori dettagli e aggiornamenti sulle certificazioni, consultare il nostro sito www.supergres.com

For further details and updated information on certifications, please visit our website www.supergres.com

Pour obtenir plus d'informations et de mises à jour sur les certifications, veuillez consulter notre site www.supergres.com

Für weitere Details und Aktualisierungen der Zertifizierungen besuchen Sie bitte unsere Internetseite www.supergres.com

Ekho T_20



Ekho Gold T20 30x120 RT . 12"x48"

EKHO T_20

GRES PORCELLANATO | PORCELAIN TILE | GRÈS CÉRAME | FEINSTEINZEUG
EN 14411 Allegato G . Piastrelle di ceramica pressate a secco con basso assorbimento d'acqua (E ≤ 0,5%) | Gruppo B la

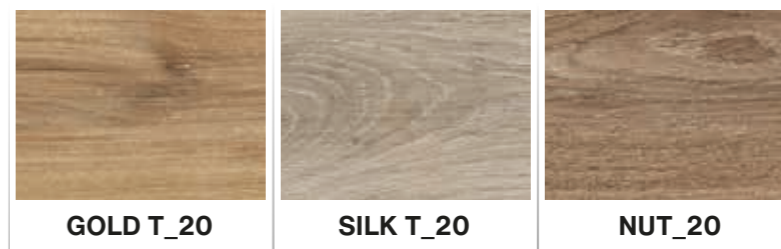

30x120 RT
R11 A+B+C
÷ 20 mm



SUPERFICIE STRUTTURATA | STRUCTURED SURFACE FINISH | FINITION STRUCTURÉE | STRUKTURIERTE OBERFLÄCHE

EKHO T_20

GRES PORCELLANATO | PORCELAIN TILE | GRÈS CÉRAMÉ | FEINSTEINZEUG

GOLD T_20



FINITURA STRUTTURATA R11 A+B+C		T_20	
KG20	30x120 RT - 12"x48"		± 20 mm
PEZZI SPECIALI LATO 120			
KGR1	round 30x120 RT - 12"x48"		± 20 mm
GKIR	round ang. interno comp. 2/pz. 30x120 RT - 12"x48"		± 20 mm
GKER	round ang. esterno comp. 2/pz. 30x120 RT - 12"x48"		± 20 mm
KGCL	costa lucida 30x120 RT - 12"x48"		± 20 mm
KGIC	ang. int. costa lucida comp. 2/pz. 30x120 RT - 12"x48"		± 20 mm
KGEC	ang. est. costa lucida comp. 2/pz. 30x120 RT - 12"x48"		± 20 mm
KG2L	terminale "elle" c/profilo incollato 20x120 RT - 8"x48"		± 20 mm

SILK T_20



FINITURA STRUTTURATA R11 A+B+C		T_20	
SK20	30x120 RT - 12"x48"		± 20 mm
PEZZI SPECIALI LATO 120			
KSTR	round 30x120 RT - 12"x48"		± 20 mm
SKIR	round ang. interno comp. 2/pz. 30x120 RT - 12"x48"		± 20 mm
SKER	round ang. esterno comp. 2/pz. 30x120 RT - 12"x48"		± 20 mm
KSCL	costa lucida 30x120 RT - 12"x48"		± 20 mm
KSIC	ang. int. costa lucida comp. 2/pz. 30x120 RT - 12"x48"		± 20 mm
KSEC	ang. est. costa lucida comp. 2/pz. 30x120 RT - 12"x48"		± 20 mm
SK2L	terminale "elle" c/profilo incollato 20x120 RT - 8"x48"		± 20 mm

NUT T_20



FINITURA STRUTTURATA R11 A+B+C		T_20	
KU20	30x120 RT - 12"x48"		± 20 mm
PEZZI SPECIALI LATO 120			
KUR1	round 30x120 RT - 12"x48"		± 20 mm
UKIR	round ang. interno comp. 2/pz. 30x120 RT - 12"x48"		± 20 mm
UKER	round ang. esterno comp. 2/pz. 30x120 RT - 12"x48"		± 20 mm
KUCL	costa lucida 30x120 RT - 12"x48"		± 20 mm
KUIC	ang. int. costa lucida comp. 2/pz. 30x120 RT - 12"x48"		± 20 mm
KUEC	ang. est. costa lucida comp. 2/pz. 30x120 RT - 12"x48"		± 20 mm
KU2L	terminale "elle" c/profilo incollato 20x120 RT - 8"x48"		± 20 mm

Imballi

EMBALLAGE | VERPACKUNG | PACKING

EKHO T_20

GRES PORCELLANATO | PORCELAIN TILE | GRÈS CÉRAMÉ | FEINSTEINZEUG

	PZ/BOX	MQ/BOX	KG/BOX	BOX/PLT	MQ/PLT	KG/PLT	SPESSORE
30x120 RT	2	0,72	32,00	36	25,92	1167	20 mm
round	1	-	-	-	-	-	20 mm
round ang/int comp. 2 pz	1 comp.	-	-	-	-	-	20 mm
round ang/est comp. 2 pz	1 comp.	-	-	-	-	-	20 mm
term. ad "elle" c/prof. inc.	2	-	-	-	-	-	20 mm
costa lucida	1	-	-	-	-	-	20 mm
ang/int costa lucida comp. 2 pz	1 comp.	-	-	-	-	-	20 mm
ang/est costa lucida comp. 2 pz	1 comp.	-	-	-	-	-	20 mm
Accessori T_20	pag. 354						
Pezzi speciali T_20	pag. 356						

Avvertenze e ulteriori informazioni sulla posa dei pavimenti T20 a pag. 348 di questo catalogo

Further information on the installation of T20 floors on page 348 of this catalogue

Pour d'ultérieures informations sur la pose des planchers T20, consultez la page 348 de ce catalogue

Weitere Informationen über die Verlegung von T20 finden Sie auf Seite 348 in diesem Katalog.

GRES PORCELLANATO | PORCELAIN TILE | GRÈS CÉRAMÉ | FEINSTEINZEUG

EN 14411 Allegato G . Piastrelle di ceramica pressate a secco con basso assorbimento d'acqua (E ≤ 0,5%)

Gruppo B Ia

Caratteristiche tecniche	Norma	Valore
Technical characteristics	Norms	Value
Resistenza all'abrasione profonda		
Abrasion resistance	ISO 10545-6	≤ 175 mm³
Resistenza allo scivolamento		
Slip resistance	EN 16165 (previously DIN 51130)	R11
Resistenza allo scivolamento - Superfici bagnate a piedi scalzi		
Coefficient of friction - Dry surfaces walking on barefoot	EN 16165 (previously DIN 51097)	A+B+C
Resistenza allo scivolamento		
Dynamic coefficient of friction (DCOF)	ANSI A326.3	Conforme According to
Coefficiente di attrito dinamico		
Dynamic friction coefficient	METODO B.C.R.A.	Conforme According to
Grado di variazione cromatica		
Colour shade variation	V1 min - V4 max	V2

Per maggiori dettagli e aggiornamenti sulle certificazioni, consultare il nostro sito www.supergres.com
 For further details and updated information on certifications, please visit our website www.supergres.com
 Pour obtenir plus d'informations et de mises à jour sur les certifications, veuillez consulter notre site www.supergres.com
 Für weitere Details und Aktualisierungen der Zertifizierungen besuchen Sie bitte unsere Internetseite www.supergres.com

Forth T_20



Porfido T_20 60x90 RT . 24"x36"

FORTH T_20

GRES PORCELLANATO | PORCELAIN TILE | GRÈS CÉRAME | FEINSTEINZEUG
EN 14411 Allegato G . Piastrelle di ceramica pressate a secco con basso assorbimento d'acqua (E ≤ 0,5%) | Gruppo B la



CHIANCA T_20



PORFIDO T_20

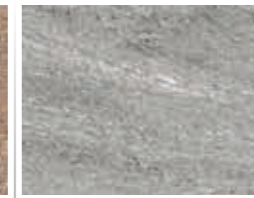

QUARZITE GRIGIA T_20



60x90 RT
R11 A+B+C
÷ 20 mm



SUPERFICIE STRUTTURATA | STRUCTURED SURFACE FINISH | FINITION STRUCTURÉE | STRUKTURIERTE OBERFLÄCHE

FORTH T_20

GRES PORCELLANATO | PORCELAIN TILE | GRÈS CÉRAME | FEINSTEINZEUG

CHIANCA T_20



FINITURA STRUTTURATA R11 A+B+C		T_20
FCH9	60x90 RT - 24"x36"	± 20 mm
PEZZI SPECIALI LATO 90		
FCR9	round 30x90 RT - 12"x36"	± 20 mm
CIF9	round ang. interno comp. 2/pz. 30x90 RT - 12"x36"	± 20 mm
CAF9	round ang. esterno comp. 2/pz. 30x90 RT - 12"x36"	± 20 mm
FCC9	costa lucida 30x90 RT - 12"x36"	± 20 mm
ICF9	ang. int. costa lucida comp. 2/pz. 30x90 RT - 12"x36"	± 20 mm
CCF9	ang. est. costa lucida comp. 2/pz. 30x90 RT - 12"x36"	± 20 mm
CFL9	terminale "elle" c/profilo incollato 20x90 RT - 8"x36"	± 20 mm

PORFIDO T_20



FINITURA STRUTTURATA R11 A+B+C		T_20
FPO9	60x90 RT - 24"x36"	± 20 mm
PEZZI SPECIALI LATO 120		
FPR9	round 30x90 RT - 12"x36"	± 20 mm
PIF9	round ang. interno comp. 2/pz. 30x90 RT - 12"x36"	± 20 mm
PAF9	round ang. esterno comp. 2/pz. 30x90 RT - 12"x36"	± 20 mm
FPC9	costa lucida 30x90 RT - 12"x36"	± 20 mm
IPF9	ang. int. costa lucida comp. 2/pz. 30x90 RT - 12"x36"	± 20 mm
PEF9	ang. est. costa lucida comp. 2/pz. 30x90 RT - 12"x36"	± 20 mm
PLF9	terminale "elle" c/profilo incollato 20x90 RT - 8"x36"	± 20 mm

QUARZITE GRIGIA T_20

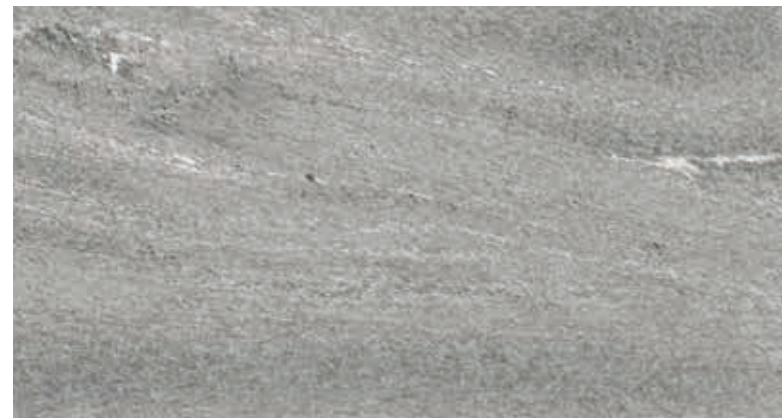

FINITURA STRUTTURATA R11 A+B+C		T_20
FQG9	60x90 RT - 24"x36"	± 20 mm
PEZZI SPECIALI LATO 120		
FQR9	round 30x90 RT - 12"x36"	± 20 mm
QIF9	round ang. interno comp. 2/pz. 30x90 RT - 12"x36"	± 20 mm
QAF9	round ang. esterno comp. 2/pz. 30x90 RT - 12"x36"	± 20 mm
FQC9	costa lucida 30x90 RT - 12"x36"	± 20 mm
IQF9	ang. int. costa lucida comp. 2/pz. 30x90 RT - 12"x36"	± 20 mm
EQF9	ang. est. costa lucida comp. 2/pz. 30x90 RT - 12"x36"	± 20 mm
QLF9	terminale "elle" c/profilo incollato 20x90 RT - 8"x36"	± 20 mm

Imballi

EMBALLAGE | VERPACKUNG | PACKING

FORTH T_20

GRES PORCELLANATO | PORCELAIN TILE | GRÈS CÉRAME | FEINSTEINZEUG

	PZ/BOX	MQ/BOX	KG/BOX	BOX/PLT	MQ/PLT	KG/PLT	SPESSORE
60x90 RT	2	1,08	48,00	24	25,92	1167	20 mm
round	1	-	-	-	-	-	20 mm
round ang/int comp. 2 pz	1 comp.	-	-	-	-	-	20 mm
round ang/est comp. 2 pz	1 comp.	-	-	-	-	-	20 mm
term. ad "elle" c/prof. inc.	2	-	-	-	-	-	20 mm
costa lucida	1	-	-	-	-	-	20 mm
ang/int costa lucida comp. 2 pz	1 comp.	-	-	-	-	-	20 mm
ang/est costa lucida comp. 2 pz	1 comp.	-	-	-	-	-	20 mm
Accessori T_20	pag. 354						
Pezzi speciali T_20	pag. 356						

Avvertenze e ulteriori informazioni sulla posa dei pavimenti T20 a pag. 348 di questo catalogo

Further information on the installation of T20 floors on page 348 of this catalogue

Pour d'ultérieures informations sur la pose des planchers T20, consultez la page 348 de ce catalogue

Weitere Informationen über die Verlegung von T20 finden Sie auf Seite 348 in diesem Katalog.

GRES PORCELLANATO | PORCELAIN TILE | GRÈS CÉRAME | FEINSTEINZEUG

EN 14411 Allegato G . Piastrelle di ceramica pressate a secco con basso assorbimento d'acqua (E ≤ 0,5%)

Gruppo B la

Caratteristiche tecniche	Norma	Valore
Technical characteristics	Norms	Value
Resistenza all'abrasione profonda		
Abrasion resistance	ISO 10545-6	≤ 175 mm ³
Resistenza allo scivolamento		
Slip resistance	EN 16165 (previously DIN 51130)	R11
Resistenza allo scivolamento - Superfici bagnate a piedi scalzi		
Coefficient of friction - Dry surfaces walking on barefoot	EN 16165 (previously DIN 51097)	A+B+C
Resistenza allo scivolamento		
Dynamic coefficient of friction (DCOF)	ANSI A326.3	Conforme According to
Coefficiente di attrito dinamico		
Dynamic friction coefficient	METODO B.C.R.A.	Conforme According to
Grado di variazione cromatica		
Colour shade variation	V1 min - V4 max	Chianca V2 - Quarzite Grigia V2 Porfido V3

Per maggiori dettagli e aggiornamenti sulle certificazioni, consultare il nostro sito www.supergres.com
 For further details and updated information on certifications, please visit our website www.supergres.com
 Pour obtenir plus d'informations et de mises à jour sur les certifications, veuillez consulter notre site www.supergres.com
 Für weitere Details und Aktualisierungen der Zertifizierungen besuchen Sie bitte unsere Internetseite www.supergres.com

Freedhome T_20



Freedhome Sand T_20 60x120 RT . 12"x24"

FREEDHOME T_20

GRES PORCELLANATO | PORCELAIN TILE | GRÈS CÉRAMÉ | FEINSTEINZEUG
EN 14411 Allegato G . Piastrelle di ceramica pressate a secco con basso assorbimento d'acqua (E ≤ 0,5%) | Gruppo B la



30x120 RT
R11 A+B+C
÷ 20 mm



SUPERFICIE STRUTTURATA | STRUCTURED SURFACE FINISH | FINITION STRUCTURÉE | STRUKTURIERTE OBERFLÄCHE

FREEDHOME T_20

GRES PORCELLANATO | PORCELAIN TILE | GRÈS CÉRAME | FEINSTEINZEUG

AMBER T_20



FINITURA STRUTTURATA R11 A+B+C		T_20	
MB30	30x120 RT - 12"x48"	T20	± 20 mm
PEZZI SPECIALI LATO 120			
FAR3	round 30x120 RT - 12"x48"		± 20 mm
FAIF	round ang. interno comp. 2/pz. 30x120 RT - 12"x48"		± 20 mm
FAEF	round ang. esterno comp. 2/pz. 30x120 RT - 12"x48"		± 20 mm
FACL	costa lucida 30x120 RT - 12"x48"		± 20 mm
FAIC	ang. int. costa lucida comp. 2/pz. 30x120 RT - 12"x48"		± 20 mm
FAEC	ang. est. costa lucida comp. 2/pz. 30x120 RT - 12"x48"		± 20 mm
FATL	terminale "elle" c/profilo incollato 20x120 RT - 8"x48"		± 20 mm

ÉCRU T_20



FINITURA STRUTTURATA R11 A+B+C		T_20	
FE30	30x120 RT - 12"x48"	T20	± 20 mm
PEZZI SPECIALI LATO 120			
EFR3	round 30x120 RT - 12"x48"		± 20 mm
FEAI	round ang. interno comp. 2/pz. 30x120 RT - 12"x48"		± 20 mm
FEAE	round ang. esterno comp. 2/pz. 30x120 RT - 12"x48"		± 20 mm
FECL	costa lucida 30x120 RT - 12"x48"		± 20 mm
FAIE	ang. int. costa lucida comp. 2/pz. 30x120 RT - 12"x48"		± 20 mm
FAEE	ang. est. costa lucida comp. 2/pz. 30x120 RT - 12"x48"		± 20 mm
FETL	terminale "elle" c/profilo incollato 20x120 RT - 8"x48"		± 20 mm

SAND T_20



FINITURA STRUTTURATA R11 A+B+C		T_20	
FD30	30x120 RT - 12"x48"	T20	± 20 mm
PEZZI SPECIALI LATO 120			
FSR3	round 30x120 RT - 12"x48"		± 20 mm
FSAI	round ang. interno comp. 2/pz. 30x120 RT - 12"x48"		± 20 mm
FSAE	round ang. esterno comp. 2/pz. 30x120 RT - 12"x48"		± 20 mm
FSCL	costa lucida 30x120 RT - 12"x48"		± 20 mm
FAIS	ang. int. costa lucida comp. 2/pz. 30x120 RT - 12"x48"		± 20 mm
FAES	ang. est. costa lucida comp. 2/pz. 30x120 RT - 12"x48"		± 20 mm
FSTL	terminale "elle" c/profilo incollato 20x120 RT - 8"x48"		± 20 mm

Imballi

EMBALLAGE | VERPACKUNG | PACKING

FREEDHOME T_20

GRES PORCELLANATO | PORCELAIN TILE | GRÈS CÉRAME | FEINSTEINZEUG

	PZ/BOX	MQ/BOX	KG/BOX	BOX/PLT	MQ/PLT	KG/PLT	SPESSORE
30x120 RT	2	0,72	32,00	36	25,92	1167	20 mm
round	1	-	-	-	-	-	20 mm
round ang/int comp. 2 pz	1 comp.	-	-	-	-	-	20 mm
round ang/est comp. 2 pz	1 comp.	-	-	-	-	-	20 mm
term. ad "elle" c/prof. inc.	2	-	-	-	-	-	20 mm
costa lucida	1	-	-	-	-	-	20 mm
ang/int costa lucida comp. 2 pz	1 comp.	-	-	-	-	-	20 mm
ang/est costa lucida comp. 2 pz	1 comp.	-	-	-	-	-	20 mm
Accessori T_20	pag. 354						
Pezzi speciali T_20	pag. 356						

Avvertenze e ulteriori informazioni sulla posa dei pavimenti T20 a pag. 348 di questo catalogo

Further information on the installation of T20 floors on page 348 of this catalogue

Pour d'ultérieures informations sur la pose des planchers T20, consultez la page 348 de ce catalogue

Weitere Informationen über die Verlegung von T20 finden Sie auf Seite 348 in diesem Katalog.

GRES PORCELLANATO | PORCELAIN TILE | GRÈS CÉRAME | FEINSTEINZEUG

EN 14411 Allegato G . Piastrelle di ceramica pressate a secco con basso assorbimento d'acqua (E ≤ 0,5%)

Gruppo B la

Caratteristiche tecniche	Norma	Valore
Technical characteristics	Norms	Value
Resistenza all'abrasione profonda		
Abrasion resistance	ISO 10545-6	≤ 175 mm ³
Resistenza allo scivolamento		
Slip resistance	EN 16165 (previously DIN 51130)	R11
Resistenza allo scivolamento - Superfici bagnate a piedi scalzi		
Coefficient of friction - Dry surfaces walking on barefoot	EN 16165 (previously DIN 51097)	A+B+C
Resistenza allo scivolamento		
Dynamic coefficient of friction (DCOF)	ANSI A326.3	Conforme According to
Coefficiente di attrito dinamico		
Dynamic friction coefficient	METODO B.C.R.A.	Conforme According to
Grado di variazione cromatica		
Colour shade variation	V1 min - V4 max	V2

Per maggiori dettagli e aggiornamenti sulle certificazioni, consultare il nostro sito www.supergres.com
 For further details and updated information on certifications, please visit our website www.supergres.com
 Pour obtenir plus d'informations et de mises à jour sur les certifications, veuillez consulter notre site www.supergres.com
 Für weitere Details und Aktualisierungen der Zertifizierungen besuchen Sie bitte unsere Internetseite www.supergres.com

Frenchmood T_20



Saint denis T_20 60x60RT - 24"x24"
Saint denis T_20 term. "elle" 20x60RT . 8"x24"

FRENCHMOOD T_20

GRES PORCELLANATO | PORCELAIN TILE | GRÈS CÉRAME | FEINSTEINZEUG
EN 14411 Allegato G . Piastrelle di ceramica pressate a secco con basso assorbimento d'acqua (E ≤ 0,5%) | Gruppo B la



CHALON T_20

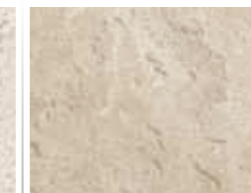

SAINT DENIS T_20



60x60 RT
R11 A+B+C
± 20 mm



SUPERFICIE STRUTTURATA | STRUCTURED SURFACE FINISH | FINITION STRUCTURÉE | STRUKTURIERTE OBERFLÄCHE

FRENCHMOOD T_20

GRES PORCELLANATO | PORCELAIN TILE | GRÈS CÉRAME | FEINSTEINZEUG

CHALON T_20



FINITURA STRUTTURATA R11 A+B+C T_20		
FCH6	60x60 RT - 24"x24"	± 20 mm
PEZZI SPECIALI LATO 60		
FCHR	round 30x60 RT - 12"x24"	± 20 mm
CRA6	round ang. interno comp. 2/pz. 30x60 RT - 12"x24"	± 20 mm
CAE6	round ang. esterno comp. 2/pz. 30x60 RT - 12"x24"	± 20 mm
SCCL	costa lucida 30x60 RT - 12"x24"	± 20 mm
AHI6	ang. int. costa lucida comp. 2/pz. 30x60 RT - 12"x24"	± 20 mm
HAE6	ang. est. costa lucida comp. 2/pz. 30x60 RT - 12"x24"	± 20 mm
GRCH	griglia 20x60 RT - 8"x24"	± 20 mm
CHGA	angolare griglia comp. 2/pz. 20x60 RT - 8"x24"	± 20 mm
FCHL	terminale "elle" c/profilo incollato 20x60 RT - 8"x24"	± 20 mm

SAINT DENIS T_20



FINITURA STRUTTURATA R11 A+B+C T_20		
S260	60x60 RT - 24"x24"	± 20 mm
PEZZI SPECIALI LATO 60		
SNR6	round 30x60 RT - 12"x24"	± 20 mm
SNA6	round ang. interno comp. 2/pz. 30x60 RT - 12"x24"	± 20 mm
SNE6	round ang. esterno comp. 2/pz. 30x60 RT - 12"x24"	± 20 mm
SDCL	costa lucida 30x60 RT - 12"x24"	± 20 mm
SDAC	ang. int. costa lucida comp. 2/pz. 30x60 RT - 12"x24"	± 20 mm
SDEC	ang. est. costa lucida comp. 2/pz. 30x60 RT - 12"x24"	± 20 mm
S2GR	griglia 20x60 RT - 8"x24"	± 20 mm
SGRA	angolare griglia comp. 2/pz. 20x60 RT - 8"x24"	± 20 mm
SDTL	terminale "elle" c/profilo incollato 20x60 RT - 8"x24"	± 20 mm

Imballi

EMBALLAGE | VERPACKUNG | PACKING

FRENCHMOOD T_20

GRES PORCELLANATO | PORCELAIN TILE | GRÈS CÉRAME | FEINSTEINZEUG

	PZ/BOX	MQ/BOX	KG/BOX	BOX/PLT	MQ/PLT	KG/PLT	SPESSORE
60x60 RT	2	0,72	32,00	30	21,60	972	20 mm
round	1	-	-	-	-	-	20 mm
round ang/int comp. 2 pz	1 comp.	-	-	-	-	-	20 mm
round ang/est comp. 2 pz	1 comp.	-	-	-	-	-	20 mm
term. ad "elle" c/prof. inc.	2	-	-	-	-	-	20 mm
griglia	1	-	-	-	-	-	20 mm
ang. griglia comp. 2 pz	1 comp.	-	-	-	-	-	20 mm
costa lucida	1	-	-	-	-	-	20 mm
ang/int costa lucida comp. 2 pz	1 comp.	-	-	-	-	-	20 mm
ang/est costa lucida comp. 2 pz	1 comp.	-	-	-	-	-	20 mm
Accessori T_20	pag. 354						
Pezzi speciali T_20	pag. 356						

Avvertenze e ulteriori informazioni sulla posa dei pavimenti T20 a pag. 348 di questo catalogo

Further information on the installation of T20 floors on page 348 of this catalogue

Pour d'ultérieures informations sur la pose des planchers T20, consultez la page 348 de ce catalogue

Weitere Informationen über die Verlegung von T20 finden Sie auf Seite 348 in diesem Katalog.

GRES PORCELLANATO | PORCELAIN TILE | GRÈS CÉRAME | FEINSTEINZEUG

EN 14411 Allegato G . Piastrelle di ceramica pressate a secco con basso assorbimento d'acqua (E ≤ 0,5%)

Gruppo B la

Caratteristiche tecniche Technical characteristics	Norma Norms	Valore Value
Resistenza all'abrasione profonda Abrasion resistance	ISO 10545-6	≤ 175 mm ³
Resistenza allo scivolamento Slip resistance	EN 16165 (previously DIN 51130)	R11
Resistenza allo scivolamento - Superfici bagnate a piedi scalzi Coefficient of friction - Dry surfaces walking on barefoot	EN 16165 (previously DIN 51097)	A+B+C
Resistenza allo scivolamento Dynamic coefficient of friction (DCOF)	ANSI A326.3	Conforme According to
Coefficiente di attrito dinamico Dynamic friction coefficient	METODO B.C.R.A.	Conforme According to
Grado di variazione cromatica Colour shade variation	V1 min - V4 max	V2

Per maggiori dettagli e aggiornamenti sulle certificazioni, consultare il nostro sito www.supergres.com
 For further details and updated information on certifications, please visit our website www.supergres.com
 Pour obtenir plus d'informations et de mises à jour sur les certifications, veuillez consulter notre site www.supergres.com
 Für weitere Details und Aktualisierungen der Zertifizierungen besuchen Sie bitte unsere Internetseite www.supergres.com

H.24 T_20



PAVIMENTO
H.Pearl T_20 60x60RT - 24"x24"
H.Pearl T_20 120x120RT - 48"x48"
H.Pearl T_20 Costa Lucida 30x60RT - 12"x24"
H.Pearl T_20 Ang. Int. Costa Lucida 30x60RT - 12"x24"

H.24 T_20

GRES PORCELLANATO | PORCELAIN TILE | GRÈS CÉRAME | FEINSTEINZEUG
EN 14411 Allegato G . Piastrelle di ceramica pressate a secco con basso assorbimento d'acqua (E ≤ 0,5%) | Gruppo B la



120x120 RT
R11 A+B+C
± 20 mm



60x60 RT
R11 A+B+C
± 20 mm



SUPERFICIE STRUTTURATA | STRUCTURED SURFACE FINISH | FINITION STRUCTURÉE | STRUKTURIERTE OBERFLÄCHE

H.24 T_20

GRES PORCELLANATO | PORCELAIN TILE | GRÈS CÉRAME | FEINSTEINZEUG

H.PEARL T_20



FINITURA STRUTTURATA R11 A+B+C T_20		
HPT1	120x120 RT - 48"x48"	± 20 mm
HPT6	60x60 RT - 24"x24"	± 20 mm
PEZZI SPECIALI LATO 60		
HPR6	round 30x60 RT - 12"x24"	± 20 mm
HPAI	round ang. interno comp. 2/pz 30x60 RT - 12"x24"	± 20 mm
HPAE	round ang. esterno comp. 2/pz 30x60 RT - 12"x24"	± 20 mm
HPCL	costa lucida 30x60 RT - 12"x24"	± 20 mm
CLPI	ang. int. costa lucida comp. 2/pz 30x60 RT - 12"x24"	± 20 mm
CLPE	ang. est. costa lucida comp. 2/pz 30x60 RT - 12"x24"	± 20 mm
HPEG	griglia 20x60 RT - 8"x24"	± 20 mm
HPAN	angolare griglia comp. 2/pz 20x60 RT - 8"x24"	± 20 mm
HPTL	terminale "elle" c/profilo incollato 20x60 RT - 8"x24"	± 20 mm
PEZZI SPECIALI LATO 120		
HPR1	round 30x120 RT - 12"x48"	± 20 mm
PHAI	round ang. interno comp. 2/pz 30x120 RT - 12"x48"	± 20 mm
PHAE	round ang. esterno comp. 2/pz 30x120 RT - 12"x48"	± 20 mm
HPEC	costa lucida 30x120 RT - 12"x48"	± 20 mm
PAIH	ang. int. costa lucida comp. 2/pz 30x120 RT - 12"x48"	± 20 mm
PAEH	ang. est. costa lucida comp. 2/pz 30x120 RT - 12"x48"	± 20 mm
HPL1	terminale "elle" c/profilo incollato 20x120 RT - 8"x48"	± 20 mm

H.CONCRETE T_20

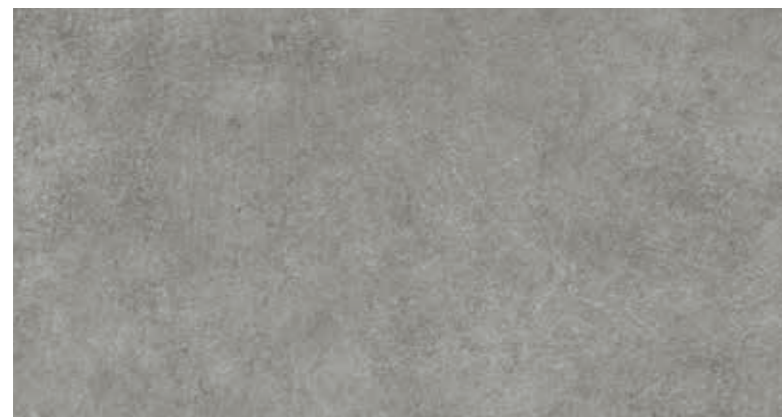

FINITURA STRUTTURATA R11 A+B+C T_20		
HCT1	120x120 RT - 48"x48"	± 20 mm
HCT6	60x60 RT - 24"x24"	± 20 mm
PEZZI SPECIALI LATO 60		
HCU6	round 30x60 RT - 12"x24"	± 20 mm
HCAI	round ang. interno comp. 2/pz 30x60 RT - 12"x24"	± 20 mm
HCAE	round ang. esterno comp. 2/pz 30x60 RT - 12"x24"	± 20 mm
HCCL	costa lucida 30x60 RT - 12"x24"	± 20 mm
CAIL	ang. int. costa lucida comp. 2/pz 30x60 RT - 12"x24"	± 20 mm
CLUC	ang. est. costa lucida comp. 2/pz 30x60 RT - 12"x24"	± 20 mm
HCNG	griglia 20x60 RT - 8"x24"	± 20 mm
CNHG	angolare griglia comp. 2/pz 20x60 RT - 8"x24"	± 20 mm
HCTL	terminale "elle" c/profilo incollato 20x60 RT - 8"x24"	± 20 mm
PEZZI SPECIALI LATO 120		
HCR1	round 30x120 RT - 12"x48"	± 20 mm
CHAI	round ang. interno comp. 2/pz 30x120 RT - 12"x48"	± 20 mm
CHAE	round ang. esterno comp. 2/pz 30x120 RT - 12"x48"	± 20 mm
CHCL	costa lucida 30x120 RT - 12"x48"	± 20 mm
CNAI	ang. int. costa lucida comp. 2/pz 30x120 RT - 12"x48"	± 20 mm
CNAE	ang. est. costa lucida comp. 2/pz 30x120 RT - 12"x48"	± 20 mm
CHT1	terminale "elle" c/profilo incollato 20x120 RT - 8"x48"	± 20 mm

H.DARK T_20

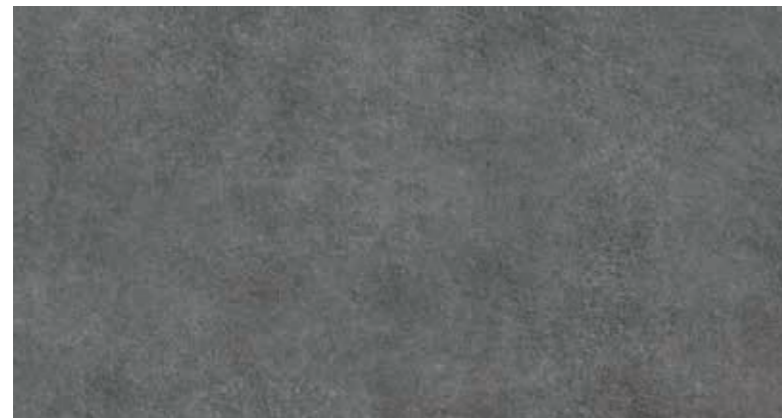

FINITURA STRUTTURATA R11 A+B+C T_20		
HDT1	120x120 RT - 48"x48"	± 20 mm
HDT6	60x60 RT - 24"x24"	± 20 mm
PEZZI SPECIALI LATO 60		
HDR6	round 30x60 RT - 12"x24"	± 20 mm
HDAI	round ang. interno comp. 2/pz 30x60 RT - 12"x24"	± 20 mm
HDAE	round ang. esterno comp. 2/pz 30x60 RT - 12"x24"	± 20 mm
HDKC	costa lucida 30x60 RT - 12"x24"	± 20 mm
CDAI	ang. int. costa lucida comp. 2/pz 30x60 RT - 12"x24"	± 20 mm
LDAE	ang. est. costa lucida comp. 2/pz 30x60 RT - 12"x24"	± 20 mm
DKGR	griglia 20x60 RT - 8"x24"	± 20 mm
HDAN	angolare griglia comp. 2/pz 20x60 RT - 8"x24"	± 20 mm
HDTL	terminale "elle" c/profilo incollato 20x60 RT - 8"x24"	± 20 mm
PEZZI SPECIALI LATO 120		
HDR1	round 30x120 RT - 12"x48"	± 20 mm
KHAI	round ang. interno comp. 2/pz 30x120 RT - 12"x48"	± 20 mm
KHAE	round ang. esterno comp. 2/pz 30x120 RT - 12"x48"	± 20 mm
HDKU	costa lucida 30x120 RT - 12"x48"	± 20 mm
DAIH	ang. int. costa lucida comp. 2/pz 30x120 RT - 12"x48"	± 20 mm
DAEH	ang. est. costa lucida comp. 2/pz 30x120 RT - 12"x48"	± 20 mm
DKL1	terminale "elle" c/profilo incollato 20x120 RT - 8"x48"	± 20 mm

Imballi

EMBALLAGE | VERPACKUNG | PACKING

H.24 T_20

GRES PORCELLANATO | PORCELAIN TILE | GRÈS CÉRAME | FEINSTEINZEUG

	PZ/BOX	MQ/BOX	KG/BOX	BOX/PLT	MQ/PLT	KG/PLT	SPESSORE
120x120 RT	1	1,44	66,00	20	28,80	1332	20 mm
60x60 RT	2	0,72	32,00	30	21,60	972	20 mm
round	1	-	-	-	-	-	20 mm
round ang/int comp. 2 pz	1 comp.	-	-	-	-	-	20 mm
round ang/est comp. 2 pz	1 comp.	-	-	-	-	-	20 mm
costa lucida	1	-	-	-	-	-	20 mm
ang/int costa lucida comp. 2 pz	1 comp.	-	-	-	-	-	20 mm
ang/est costa lucida comp. 2 pz	1 comp.	-	-	-	-	-	20 mm
term. ad "elle" c/prof. inc.	2	-	-	-	-	-	20 mm
griglia	1	-	-	-	-	-	20 mm
ang. griglia comp. 2 pz	1 comp.	-	-	-	-	-	20 mm
Accessori T_20	pag. 354						
Pezzi speciali T_20	pag. 356						

Avvertenze e ulteriori informazioni sulla posa dei pavimenti T20 a pag. 348 di questo catalogo

Further information on the installation of T20 floors on page 348 of this catalogue

Pour d'ultérieures informations sur la pose des planchers T20, consultez la page 348 de ce catalogue

Weitere Informationen über die Verlegung von T20 finden Sie auf Seite 348 in diesem Katalog.

GRES PORCELLANATO | PORCELAIN TILE | GRÈS CÉRAME | FEINSTEINZEUG

EN 14411 Allegato G . Piastrelle di ceramica pressate a secco con basso assorbimento d'acqua (E ≤ 0,5%)

Gruppo B la

Caratteristiche tecniche Technical characteristics	Norma Norms	Valore Value
Resistenza all'abrasione profonda Abrasion resistance	ISO 10545-6	≤ 175 mm ³
Resistenza allo scivolamento Slip resistance	EN 16165 (previously DIN 51130)	R11
Resistenza allo scivolamento - Superfici bagnate a piedi scalzi Coefficient of friction - Dry surfaces walking on barefoot	EN 16165 (previously DIN 51097)	A+B+C
Resistenza allo scivolamento Dynamic coefficient of friction (DCOF)	ANSI A326.3	Conforme According to
Coefficiente di attrito dinamico Dynamic friction coefficient	METODO B.C.R.A.	Conforme According to
Grado di variazione cromatica Colour shade variation	V1 min - V4 max	V2

Per maggiori dettagli e aggiornamenti sulle certificazioni, consultare il nostro sito www.supergres.com
For further details and updated information on certifications, please visit our website www.supergres.com
Pour obtenir plus d'informations et de mises à jour sur les certifications, veuillez consulter notre site www.supergres.com
Für weitere Details und Aktualisierungen der Zertifizierungen besuchen Sie bitte unsere Internetseite www.supergres.com

Overtime T_20



Time Grey T20 60x120 RT - 24"x48"
Time Grey T20 round 30x120 RT - 12"x48"
Time Grey T20 A/I round 30x120 RT - 12"x48"

OVERTIME T_20

GRES PORCELLANATO | PORCELAIN TILE | GRÈS CÉRAMÉ | FEINSTEINZEUG
EN 14411 Allegato G . Piastrelle di ceramica pressate a secco con basso assorbimento d'acqua (E ≤ 0,5%) | Gruppo B la

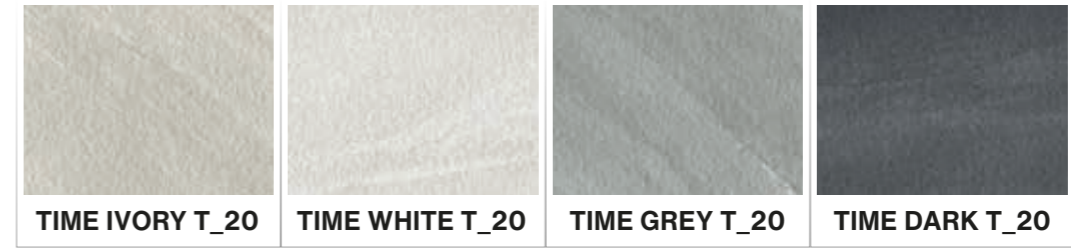

60x120 RT
R11 A+B+C
± 20 mm



60x60 RT
R11 A+B+C
± 20 mm



SUPERFICIE STRUTTURATA | STRUCTURED SURFACE FINISH | FINITION STRUCTURÉE | STRUKTURIERTE OBERFLÄCHE

OVERTIME T_20

GRES PORCELLANATO | PORCELAIN TILE | GRÈS CÉRAMÉ | FEINSTEINZEUG

TIME IVORY T_20



FINITURA STRUTTURATA R11 A+B+C T_20		
TIV1	60x120 RT - 24"x48"	± 20 mm
TIV6	60x60 RT - 24"x24"	± 20 mm
PEZZI SPECIALI LATO 60		
IR06	round 30x60 RT - 12"x24"	± 20 mm
IRI6	round ang. interno comp. 2/pz. 30x60 RT - 12"x24"	± 20 mm
IRE6	round ang. esterno comp. 2/pz. 30x60 RT - 12"x24"	± 20 mm
TICL	costa lucida 30x60 RT - 12"x24"	± 20 mm
ICI6	ang. int. costa lucida comp. 2/pz. 30x60 RT - 12"x24"	± 20 mm
ICE6	ang. est. costa lucida comp. 2/pz. 30x60 RT - 12"x24"	± 20 mm
IVG2	griglia 20x60 RT - 8"x24"	± 20 mm
IVAG	angolare griglia comp. 2/pz. 20x60 RT - 8"x24"	± 20 mm
ITL6	terminale "elle" c/profilo incollato 20x60 RT - 8"x24"	± 20 mm
PEZZI SPECIALI LATO 120		
TIR1	round 30x120 RT - 12"x48"	± 20 mm
TII1	round ang. interno comp. 2/pz. 30x120 RT - 12"x48"	± 20 mm
TVE1	round ang. esterno comp. 2/pz. 30x120 RT - 12"x48"	± 20 mm
TIL1	costa lucida 30x120 RT - 12"x48"	± 20 mm
TCI1	ang. int. costa lucida comp. 2/pz. 30x120 RT - 12"x48"	± 20 mm
VCE1	ang. est. costa lucida comp. 2/pz. 30x120 RT - 12"x48"	± 20 mm
IVL1	terminale "elle" c/profilo incollato 20x120 RT - 8"x48"	± 20 mm

TIME GREY T_20

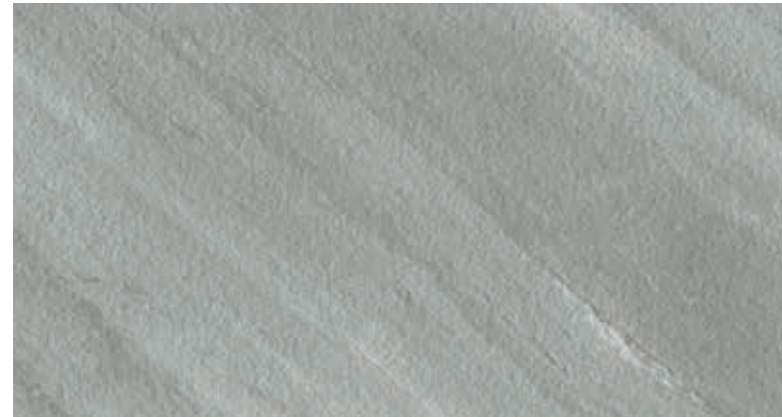

FINITURA STRUTTURATA R11 A+B+C T_20		
TGR1	60x120 RT - 24"x48"	± 20 mm
TGR6	60x60 RT - 24"x24"	± 20 mm
PEZZI SPECIALI LATO 60		
TRO6	round 30x60 RT - 12"x24"	± 20 mm
GYI6	round ang. interno comp. 2/pz. 30x60 RT - 12"x24"	± 20 mm
GYE6	round ang. esterno comp. 2/pz. 30x60 RT - 12"x24"	± 20 mm
GYCL	costa lucida 30x60 RT - 12"x24"	± 20 mm
GCI6	ang. int. costa lucida comp. 2/pz. 30x60 RT - 12"x24"	± 20 mm
GCE6	ang. est. costa lucida comp. 2/pz. 30x60 RT - 12"x24"	± 20 mm
GYG2	griglia 20x60 RT - 8"x24"	± 20 mm
GRYG	angolare griglia comp. 2/pz. 20x60 RT - 8"x24"	± 20 mm
GTL6	terminale "elle" c/profilo incollato 20x60 RT - 8"x24"	± 20 mm
PEZZI SPECIALI LATO 120		
TYR1	round 30x120 RT - 12"x48"	± 20 mm
TYI1	round ang. interno comp. 2/pz. 30x120 RT - 12"x48"	± 20 mm
TYE1	round ang. esterno comp. 2/pz. 30x120 RT - 12"x48"	± 20 mm
TGL1	costa lucida 30x120 RT - 12"x48"	± 20 mm
GCE1	ang. int. costa lucida comp. 2/pz. 30x120 RT - 12"x48"	± 20 mm
YCE1	ang. est. costa lucida comp. 2/pz. 30x120 RT - 12"x48"	± 20 mm
GYL1	terminale "elle" c/profilo incollato 20x120 RT - 8"x48"	± 20 mm

TIME DARK T_20



FINITURA STRUTTURATA R11 A+B+C T_20		
TDK1	60x120 RT - 24"x48"	± 20 mm
TDK6	60x60 RT - 24"x24"	± 20 mm
PEZZI SPECIALI LATO 60		
DRO6	round 30x60 RT - 12"x24"	± 20 mm
DKI6	round ang. interno comp. 2/pz. 30x60 RT - 12"x24"	± 20 mm
DKE6	round ang. esterno comp. 2/pz. 30x60 RT - 12"x24"	± 20 mm
TDCL	costa lucida 30x60 RT - 12"x24"	± 20 mm
DCI6	ang. int. costa lucida comp. 2/pz. 30x60 RT - 12"x24"	± 20 mm
DCE6	ang. est. costa lucida comp. 2/pz. 30x60 RT - 12"x24"	± 20 mm
DKG2	griglia 20x60 RT - 8"x24"	± 20 mm
DKAG	angolare griglia comp. 2/pz. 20x60 RT - 8"x24"	± 20 mm
DTL6	terminale "elle" c/profilo incollato 20x60 RT - 8"x24"	± 20 mm
PEZZI SPECIALI LATO 120		
TDR1	round 30x120 RT - 12"x48"	± 20 mm
TKI1	round ang. interno comp. 2/pz. 30x120 RT - 12"x48"	± 20 mm
TKE1	round ang. esterno comp. 2/pz. 30x120 RT - 12"x48"	± 20 mm
TDC1	costa lucida 30x120 RT - 12"x48"	± 20 mm
KL1C	ang. int. costa lucida comp. 2/pz. 30x120 RT - 12"x48"	± 20 mm
KLE1	ang. est. costa lucida comp. 2/pz. 30x120 RT - 12"x48"	± 20 mm
TKL1	terminale "elle" c/profilo incollato 20x120 RT - 8"x48"	± 20 mm

TIME WHITE T_20



FINITURA STRUTTURATA R11 A+B+C T_20		
TWT2	60x120 RT - 24"x48"	± 20 mm
THT6	60x60 RT - 24"x24"	± 20 mm
PEZZI SPECIALI LATO 60		
TWHR	round 30x60 RT - 12"x24"	± 20 mm
TWI6	round ang. interno comp. 2/pz. 30x60 RT - 12"x24"	± 20 mm
TWE6	round ang. esterno comp. 2/pz. 30x60 RT - 12"x24"	± 20 mm
TWCL	costa lucida 30x60 RT - 12"x24"	± 20 mm
TWIL	ang. int. costa lucida comp. 2/pz. 30x60 RT - 12"x24"	± 20 mm
TWEL	ang. est. costa lucida comp. 2/pz. 30x60 RT - 12"x24"	± 20 mm
EHGR	griglia 20x60 RT - 8"x24"	± 20 mm
WHAG	angolare griglia comp. 2/pz. 20x60 RT - 8"x24"	± 20 mm
TWL6	terminale "elle" c/profilo incollato 20x60 RT - 8"x24"	± 20 mm
PEZZI SPECIALI LATO 120		
TWIR	round 30x120 RT - 12"x48"	± 20 mm
TWHI	round ang. interno comp. 2/pz. 30x120 RT - 12"x48"	± 20 mm
TWHE	round ang. esterno comp. 2/pz. 30x120 RT - 12"x48"	± 20 mm
T1WL	costa lucida 30x120 RT - 12"x48"	± 20 mm
TIHL	ang. int. costa lucida comp. 2/pz. 30x120 RT - 12"x48"	± 20 mm
TEHL	ang. est. costa lucida comp. 2/pz. 30x120 RT - 12"x48"	± 20 mm
TWHL	terminale "elle" c/profilo incollato 20x120 RT - 8"x48"	± 20 mm

Imballi EMBALLAGE | VERPACKUNG | PACKING

OVERTIME T_20

GRES PORCELLANATO | PORCELAIN TILE | GRÈS CÉRAMÉ | FEINSTEINZEUG

	PZ/BOX	MQ/BOX	KG/BOX	BOX/PLT	MQ/PLT	KG/PLT	SPESSORE
60x120 RT	1	0,72	32,00	35	25,20	1135	20 mm
60x60 RT	2	0,72	32,00	30	21,60	972	20 mm
round	1	-	-	-	-	-	20 mm
round ang/int comp. 2 pz	1 comp.	-	-	-	-	-	20 mm
round ang/est comp. 2 pz	1 comp.	-	-	-	-	-	20 mm
costa lucida	1	-	-	-	-	-	20 mm
ang/int costa lucida comp. 2 pz	1 comp.	-	-	-	-	-	20 mm
ang/est costa lucida comp. 2 pz	1 comp.	-	-	-	-	-	20 mm
griglia	1	-	-	-	-	-	20 mm
ang. griglia comp. 2 pz	1 comp.	-	-	-	-	-	20 mm
term. ad "elle" c/prof. inc.	2	-	-	-	-	-	20 mm
Accessori T_20	pag. 354						
Pezzi speciali T_20	pag. 356						

Avvertenze e ulteriori informazioni sulla posa dei pavimenti T20 a pag. 348 di questo catalogo / Further information on the installation of T20 floors on page 348 of this catalogue
 Pour d'ultérieures informations sur la pose des planchers T20, consultez la page 348 de ce catalogue / Weitere Informationen über die Verlegung von T20 finden Sie auf Seite 348 in diesem Katalog.

GRES PORCELLANATO | PORCELAIN TILE | GRÈS CÉRAMÉ | FEINSTEINZEUG

EN 14411 Allegato G . Piastrelle di ceramica pressate a secco con basso assorbimento d'acqua (E ≤ 0,5%)

Gruppo B la

Caratteristiche tecniche Technical characteristics	Norma Norms	Valore Value
Resistenza all'abrasione profonda Abrasion resistance	ISO 10545-6	≤ 175 mm ³
Resistenza allo scivolamento Slip resistance	EN 16165 (previously DIN 51130)	R11
Resistenza allo scivolamento - Superfici bagnate a piedi scalzi Coefficient of friction - Dry surfaces walking on barefoot	EN 16165 (previously DIN 51097)	A+B+C
Resistenza allo scivolamento Dynamic coefficient of friction (DCOF)	ANSI A326.3	Conforme According to
Coefficiente di attrito dinamico Dynamic friction coefficient	METODO B.C.R.A.	Conforme According to
Grado di variazione cromatica Colour shade variation	V1 min - V4 max	V2

Per maggiori dettagli e aggiornamenti sulle certificazioni, consultare il nostro sito www.supergres.com / For further details and updated information on certifications, please visit our website www.supergres.com / Pour obtenir plus d'informations et de mises à jour sur les certifications, veuillez consulter notre site www.supergres.com / Für weitere Details und Aktualisierungen der Zertifizierungen besuchen Sie bitte unsere Internetseite www.supergres.com

Stockholm T_20



PAVIMENTO
Mandel T_20 60x60 RT - 24"x24"
Mandel T_20 round 30x60RT - 12"x24"
Mandel T_20 round ang.interno 30x60RT - 12"x24"
Mandel T_20 griglia 20x60RT - 8"x24"
Mandel T_20 ang. griglia 20x60RT - 8"x24"

STOCKHOLM T_20

GRES PORCELLANATO | PORCELAIN TILE | GRÈS CÉRAMÉ | FEINSTEINZEUG
EN 14411 Allegato G . Piastrelle di ceramica pressate a secco con basso assorbimento d'acqua (E ≤ 0,5%) | Gruppo B la



60x60 RT
R11 A+B+C
± 20 mm



SUPERFICIE STRUTTURATA | STRUCTURED SURFACE FINISH | FINITION STRUCTURÉE | STRUKTURIERTE OBERFLÄCHE

STOCKHOLM T_20

GRES PORCELLANATO | PORCELAIN TILE | GRÈS CÉRAME | FEINSTEINZEUG

MANDEL T_20

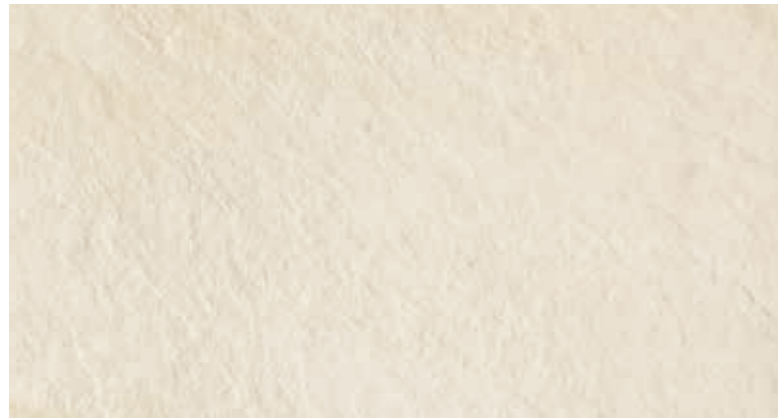

FINITURA STRUTTURATA R11 A+B+C		T_20
MN2Ø	60x60 RT - 24"x24"	± 20 mm
PEZZI SPECIALI LATO 60		
MNRO	round 30x60 RT - 12"x24"	± 20 mm
MNAR	round ang. interno comp. 2/pz. 30x60 RT - 12"x24"	± 20 mm
MNER	round ang. esterno comp. 2/pz. 30x60 RT - 12"x24"	± 20 mm
MNGR	griglia 20x60 RT - 8"x24"	± 20 mm
MNAG	angolare griglia comp. 2/pz. 20x60 RT - 8"x24"	± 20 mm
M2TL	terminale "elle" c/profilo incollato 20x60 RT - 8"x24"	± 20 mm

GRAU T_20



FINITURA STRUTTURATA R11 A+B+C		T_20
GR2Ø	60x60 RT - 24"x24"	± 20 mm
PEZZI SPECIALI LATO 60		
GRRO	round 30x60 RT - 12"x24"	± 20 mm
GRAR	round ang. interno comp. 2/pz. 30x60 RT - 12"x24"	± 20 mm
GRER	round ang. esterno comp. 2/pz. 30x60 RT - 12"x24"	± 20 mm
GUGR	griglia 20x60 RT - 8"x24"	± 20 mm
GRAG	angolare griglia comp. 2/pz. 20x60 RT - 8"x24"	± 20 mm
G2TL	terminale "elle" c/profilo incollato 20x60 RT - 8"x24"	± 20 mm

Imballi

EMBALLAGE | VERPACKUNG | PACKING

STOCKHOLM T_20

GRES PORCELLANATO | PORCELAIN TILE | GRÈS CÉRAME | FEINSTEINZEUG

	PZ/BOX	MQ/BOX	KG/BOX	BOX/PLT	MQ/PLT	KG/PLT	SPESSORE
60x60 RT	2	0,72	32,00	30	21,60	972	20 mm
round	1	-	-	-	-	-	20 mm
round ang/int comp. 2 pz	1 comp.	-	-	-	-	-	20 mm
round ang/est comp. 2 pz	1 comp.	-	-	-	-	-	20 mm
term. ad "elle" c/prof. inc.	2	-	-	-	-	-	20 mm
griglia	1	-	-	-	-	-	20 mm
ang. griglia comp. 2 pz	1 comp.	-	-	-	-	-	20 mm
Accessori T_20	pag. 354						
Pezzi speciali T_20	pag. 356						

Avvertenze e ulteriori informazioni sulla posa dei pavimenti T20 a pag. 348 di questo catalogo

Further information on the installation of T20 floors on page 348 of this catalogue

Pour d'ultérieures informations sur la pose des planchers T20, consultez la page 348 de ce catalogue

Weitere Informationen über die Verlegung von T20 finden Sie auf Seite 348 in diesem Katalog.

GRES PORCELLANATO | PORCELAIN TILE | GRÈS CÉRAME | FEINSTEINZEUG

EN 14411 Allegato G . Piastrelle di ceramica pressate a secco con basso assorbimento d'acqua (E ≤ 0,5%)

Gruppo B Ia

Caratteristiche tecniche Technical characteristics	Norma Norms	Valore Value
Resistenza all'abrasione profonda Abrasion resistance	ISO 10545-6	≤ 175 mm ³
Resistenza allo scivolamento Slip resistance	EN 16165 (previously DIN 51130)	R11
Resistenza allo scivolamento - Superfici bagnate a piedi scalzi Coefficient of friction - Dry surfaces walking on barefoot	EN 16165 (previously DIN 51097)	A+B+C
Resistenza allo scivolamento Dynamic coefficient of friction (DCOF)	ANSI A326.3	Conforme According to
Coefficiente di attrito dinamico Dynamic friction coefficient	METODO B.C.R.A.	Conforme According to
Grado di variazione cromatica Colour shade variation	V1 min - V4 max	V2

Per maggiori dettagli e aggiornamenti sulle certificazioni, consultare il nostro sito www.supergres.com
For further details and updated information on certifications, please visit our website www.supergres.com
Pour obtenir plus d'informations et de mises à jour sur les certifications, veuillez consulter notre site www.supergres.com
Für weitere Details und Aktualisierungen der Zertifizierungen besuchen Sie bitte unsere Internetseite www.supergres.com

Stonework T_20



Beola T_20 60x60 RT - 24"x24"
Beola term. elle 20x60 RT - 8"x24"

STONWORK T_20

GRES PORCELLANATO | PORCELAIN TILE | GRÈS CÉRAME | FEINSTEINZEUG
EN 14411 Allegato G . Piastrelle di ceramica pressate a secco con basso assorbimento d'acqua (E ≤ 0,5%) | Gruppo B la

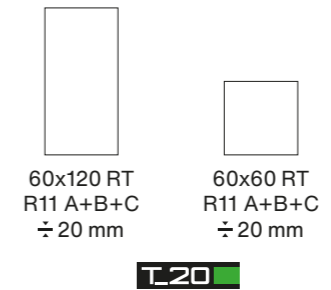

T20

SUPERFICIE STRUTTURATA | STRUCTURED SURFACE FINISH | FINITION STRUCTURÉE | STRUKTURIERTE OBERFLÄCHE

STONWORK T_20

GRES PORCELLANATO | PORCELAIN TILE | GRÈS CÉRAME | FEINSTEINZEUG

BEOLA T_20

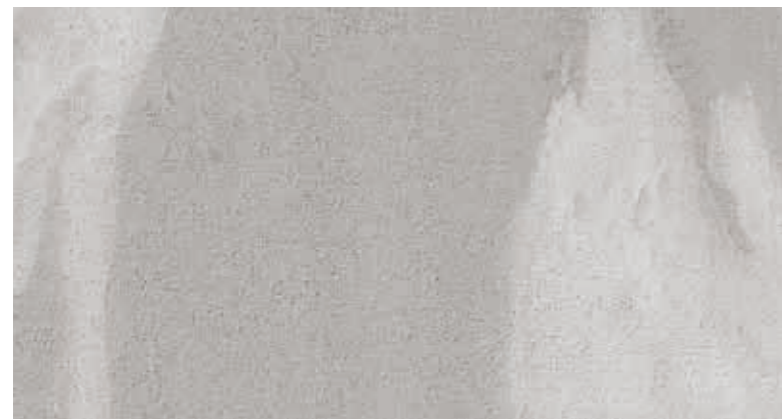

FINITURA STRUTTURATA R11 A+B+C T_20		
BET2	60x120 RT - 24"x48"	± 20 mm
BE6T	60x60 RT - 24"x24"	± 20 mm
PEZZI SPECIALI LATO 60		
BERN	round 30x60 RT - 12"x24"	± 20 mm
BEAI	round ang. interno comp. 2/pz. 30x60 RT - 12"x24"	± 20 mm
BEAE	round ang. esterno comp. 2/pz. 30x60 RT - 12"x24"	± 20 mm
BECL	costa lucida 30x60 RT - 12"x24"	± 20 mm
BCAI	ang. int. costa lucida comp. 2/pz. 30x60 RT - 12"x24"	± 20 mm
BCAE	ang. est. costa lucida comp. 2/pz. 30x60 RT - 12"x24"	± 20 mm
BTGR	griglia 20x60 RT - 8"x24"	± 20 mm
BANG	angolare griglia comp. 2/pz. 20x60 RT - 8"x24"	± 20 mm
BETL	terminale "elle" c/profilo incollato 20x60 RT - 8"x24"	± 20 mm
PEZZI SPECIALI LATO 120		
BER1	round 30x120 RT - 12"x48"	± 20 mm
BEIR	round ang. interno comp. 2/pz. 30x120 RT - 12"x48"	± 20 mm
BEER	round ang. esterno comp. 2/pz. 30x120 RT - 12"x48"	± 20 mm
BOL1	costa lucida 30x120 RT - 12"x48"	± 20 mm
CEAI	ang. int. costa lucida comp. 2/pz. 30x120 RT - 12"x48"	± 20 mm
CEAE	ang. est. costa lucida comp. 2/pz. 30x120 RT - 12"x48"	± 20 mm
BEL1	terminale "elle" c/profilo incollato 20x120 RT - 8"x48"	± 20 mm

LUGNEZ T_20



FINITURA STRUTTURATA R11 A+B+C T_20		
LUT2	60x120 RT - 24"x48"	± 20 mm
LUT6	60x60 RT - 24"x24"	± 20 mm
PEZZI SPECIALI LATO 60		
LURN	round 30x60 RT - 12"x24"	± 20 mm
LUAI	round ang. interno comp. 2/pz. 30x60 RT - 12"x24"	± 20 mm
LUAE	round ang. esterno comp. 2/pz. 30x60 RT - 12"x24"	± 20 mm
LCL6	costa lucida 30x60 RT - 12"x24"	± 20 mm
LAI6	ang. int. costa lucida comp. 2/pz. 30x60 RT - 12"x24"	± 20 mm
LAE6	ang. est. costa lucida comp. 2/pz. 30x60 RT - 12"x24"	± 20 mm
UT2G	griglia 20x60 RT - 8"x24"	± 20 mm
LANG	angolare griglia comp. 2/pz. 20x60 RT - 8"x24"	± 20 mm
LUTL	terminale "elle" c/profilo incollato 20x60 RT - 8"x24"	± 20 mm
PEZZI SPECIALI LATO 120		
LUR1	round 30x120 RT - 12"x48"	± 20 mm
LUAR	round ang. interno comp. 2/pz. 30x120 RT - 12"x48"	± 20 mm
LUER	round ang. esterno comp. 2/pz. 30x120 RT - 12"x48"	± 20 mm
LUC1	costa lucida 30x120 RT - 12"x48"	± 20 mm
LTAI	ang. int. costa lucida comp. 2/pz. 30x120 RT - 12"x48"	± 20 mm
UTAE	ang. est. costa lucida comp. 2/pz. 30x120 RT - 12"x48"	± 20 mm
LUL1	terminale "elle" c/profilo incollato 20x120 RT - 8"x48"	± 20 mm

ARDESIA NERA T_20

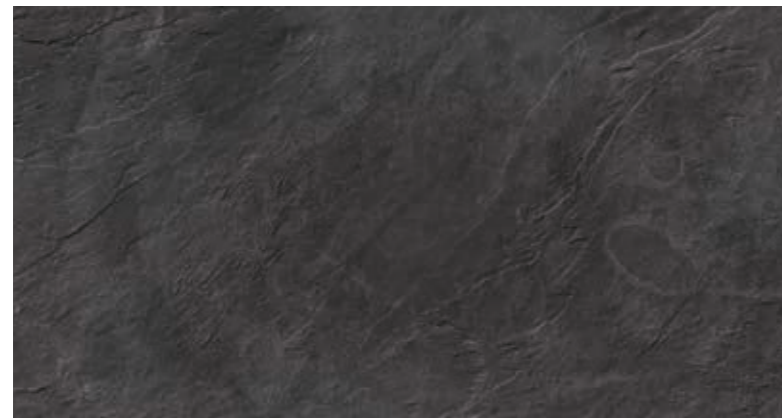

FINITURA STRUTTURATA R11 A+B+C T_20		
TAD2	60x120 RT - 24"x48"	± 20 mm
AN6T	60x60 RT - 24"x24"	± 20 mm
PEZZI SPECIALI LATO 60		
AERN	round 30x60 RT - 12"x24"	± 20 mm
ATAI	round ang. interno comp. 2/pz. 30x60 RT - 12"x24"	± 20 mm
DNAR	round ang. esterno comp. 2/pz. 30x60 RT - 12"x24"	± 20 mm
DCL6	costa lucida 30x60 RT - 12"x24"	± 20 mm
DAIC	ang. int. costa lucida comp. 2/pz. 30x60 RT - 12"x24"	± 20 mm
DAEC	ang. est. costa lucida comp. / 2 pz. 30x60 RT - 12"x24"	± 20 mm
DTGR	griglia 20x60 RT - 8"x24"	± 20 mm
AANG	angolare griglia comp. 2/pz. 20x60 RT - 8"x24"	± 20 mm
DNTL	terminale "elle" c/profilo incollato 20x60 RT - 8"x24"	± 20 mm
PEZZI SPECIALI LATO 120		
ARU1	round 30x120 RT - 12"x48"	± 20 mm
DNIR	round ang. interno comp. 2/pz. 30x120 RT - 12"x48"	± 20 mm
DNER	round ang. esterno comp. 2/pz. 30x120 RT - 12"x48"	± 20 mm
RCL1	costa lucida 30x120 RT - 12"x48"	± 20 mm
RLAI	ang. int. costa lucida comp. 2/pz. 30x120 RT - 12"x48"	± 20 mm
RLAE	ang. est. costa lucida comp. 2/pz. 30x120 RT - 12"x48"	± 20 mm
DTL1	terminale "elle" c/profilo incollato 20x120 RT - 8"x48"	± 20 mm

Imballi

EMBALLAGE | VERPACKUNG | PACKING

STONWORK T_20

GRES PORCELLANATO | PORCELAIN TILE | GRÈS CÉRAME | FEINSTEINZEUG

	PZ/BOX	MQ/BOX	KG/BOX	BOX/PLT	MQ/PLT	KG/PLT	SPESSORE
60x120 RT	1	0,72	32,00	35	25,20	1135	20 mm
60x60 RT	2	0,72	32,00	30	21,60	972	20 mm
round	1	-	-	-	-	-	20 mm
round ang/int comp. 2 pz	1 comp.	-	-	-	-	-	20 mm
round ang/est comp. 2 pz	1 comp.	-	-	-	-	-	20 mm
costa lucida	1	-	-	-	-	-	20 mm
ang/int costa lucida comp. 2 pz	1 comp.	-	-	-	-	-	20 mm
ang/est costa lucida comp. 2 pz	1 comp.	-	-	-	-	-	20 mm
term. ad "elle" c/prof. inc.	2	-	-	-	-	-	20 mm
griglia	1	-	-	-	-	-	20 mm
ang. griglia comp. 2 pz	1 comp.	-	-	-	-	-	20 mm
Accessori T_20	pag. 354						
Pezzi speciali T_20	pag. 356						

Avvertenze e ulteriori informazioni sulla posa dei pavimenti T20 a pag. 348 di questo catalogo

Further information on the installation of T20 floors on page 348 of this catalogue

Pour d'ultérieures informations sur la pose des planchers T20, consultez la page 348 de ce catalogue

Weitere Informationen über die Verlegung von T20 finden Sie auf Seite 348 in diesem Katalog.

GRES PORCELLANATO | PORCELAIN TILE | GRÈS CÉRAME | FEINSTEINZEUG

EN 14411 Allegato G . Piastrelle di ceramica pressate a secco con basso assorbimento d'acqua (E ≤ 0,5%)

Gruppo B la

Caratteristiche tecniche Technical characteristics	Norma Norms	Valore Value
Resistenza all'abrasione profonda Abrasion resistance	ISO 10545-6	≤ 175 mm ³
Resistenza allo scivolamento Slip resistance	EN 16165 (previously DIN 51130)	R11
Resistenza allo scivolamento - Superfici bagnate a piedi scalzi Coefficient of friction - Dry surfaces walking on barefoot	EN 16165 (previously DIN 51097)	A+B+C
Resistenza allo scivolamento Dynamic coefficient of friction (DCOF)	ANSI A326.3	Conforme According to
Coefficiente di attrito dinamico Dynamic friction coefficient	METODO B.C.R.A.	Conforme According to
Grado di variazione cromatica Colour shade variation	V1 min - V4 max	Ardesia Nera V2 - Lugnez V2 Beola V3

Per maggiori dettagli e aggiornamenti sulle certificazioni, consultare il nostro sito www.supergres.comFor further details and updated information on certifications, please visit our website www.supergres.comPour obtenir plus d'informations et de mises à jour sur les certifications, veuillez consulter notre site www.supergres.comFür weitere Details und Aktualisierungen der Zertifizierungen besuchen Sie bitte unsere Internetseite www.supergres.com

Story T_20



PAVIMENTO
Story ivory T_20 45x90 RT - 18"x36"
Story ivory T_20 term. "elle" 22,5x90 RT - 9"x36"

STORY T_20

GRES PORCELLANATO | PORCELAIN TILE | GRÈS CÉRAME | FEINSTEINZEUG
EN 14411 Allegato G . Piastrelle di ceramica pressate a secco con basso assorbimento d'acqua (E ≤ 0,5%) | Gruppo B la



STORY IVORY T_20



STORY GREY T_20



80x80 RT
R11 A+B+C
± 20 mm



45x90 RT
R11 A+B+C
± 20 mm



SUPERFICIE STRUTTURATA | STRUCTURED SURFACE FINISH | FINITION STRUCTURÉE | STRUKTURIERTE OBERFLÄCHE

STORY T_20

GRES PORCELLANATO | PORCELAIN TILE | GRÈS CÉRAME | FEINSTEINZEUG

STORY IVORY T_20



FINITURA STRUTTURATA R11 A+B+C T_20		
STI8	80x80 RT - 32"x32"	± 20 mm
STI4	45x90 RT - 18"x36"	± 20 mm
PEZZI SPECIALI LATO 90		
SIR9	round 45x90 RT - 18"x36"	± 20 mm
SIAl	round ang. interno comp. / 2 pz. 45x90 RT - 18"x36"	± 20 mm
SIAE	round ang. esterno comp. / 2 pz. 45x90 RT - 18"x36"	± 20 mm
SVCL	costa lucida 45x90 RT - 18"x36"	± 20 mm
VCAI	ang. int. costa lucida comp. / 2 pz. 45x90 RT - 18"x36"	± 20 mm
VCAE	ang. est. costa lucida comp. / 2 pz. 45x90 RT - 18"x36"	± 20 mm
SI5G	griglia 20x45 RT - 8"x18"	± 20 mm
SOAG	angolare griglia comp. / 2 pz. 20x45 RT - 8"x18"	± 20 mm
SIL9	terminale "elle" c/profilo incollato 22,5x90 RT - 9"x36"	± 20 mm
PEZZI SPECIALI LATO 80		
SIR8	round 40x80 RT - 16"x32"	± 20 mm
IAIR	round ang. interno comp. 2/pz. 40x80 RT - 16"x32"	± 20 mm
IAER	round ang. esterno comp. 2/pz. 40x80 RT - 16"x32"	± 20 mm
ICL8	costa lucida 40x80 RT - 16"x32"	± 20 mm
IAI8	ang. int. costa lucida comp. 2/pz. 40x80 RT - 16"x32"	± 20 mm
IAE8	ang. est. costa lucida comp. 2/pz. 40x80 RT - 16"x32"	± 20 mm
ITL8	terminale "elle" c/profilo incollato 20x80 RT - 8"x32"	± 20 mm

STORY GREY T_20

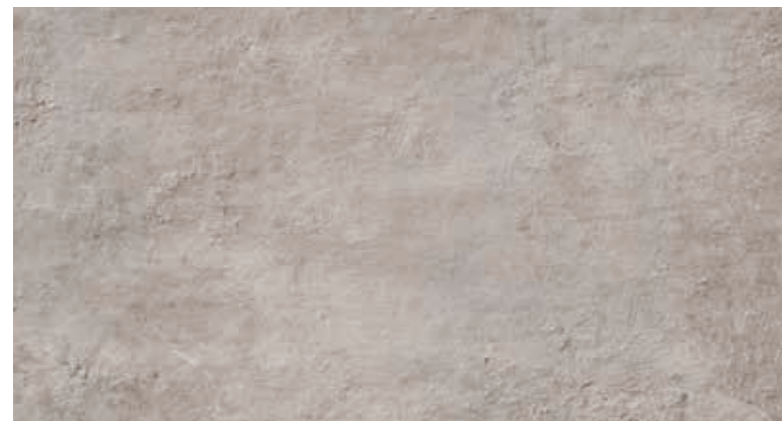

FINITURA STRUTTURATA R11 A+B+C T_20		
STG8	80x80 RT - 32"x32"	± 20 mm
S2G4	45x90 RT - 18"x36"	± 20 mm
PEZZI SPECIALI LATO 90		
SRY9	round 45x90 RT - 18"x36"	± 20 mm
SGAI	round ang. interno comp. / 2 pz. 45x90 RT - 18"x36"	± 20 mm
SGAE	round ang. esterno comp. / 2 pz. 45x90 RT - 18"x36"	± 20 mm
SGCL	costa lucida 45x90 RT - 18"x36"	± 20 mm
GCAI	ang. int. costa lucida comp. / 2 pz. 45x90 RT - 18"x36"	± 20 mm
GCAE	ang. est. costa lucida comp. / 2 pz. 45x90 RT - 18"x36"	± 20 mm
SG5G	griglia 20x45 RT - 8"x18"	± 20 mm
SRAG	angolare griglia comp. / 2 pz. 20x45 RT - 8"x18"	± 20 mm
SGL9	terminale "elle" c/profilo incollato 22,5x90 RT - 9"x36"	± 20 mm
PEZZI SPECIALI LATO 80		
SGR8	round 40x80 RT - 16"x32"	± 20 mm
GA8I	round ang. interno comp. 2/pz. 40x80 RT - 16"x32"	± 20 mm
GA8E	round ang. esterno comp. 2/pz. 40x80 RT - 16"x32"	± 20 mm
GCL8	costa lucida 40x80 RT - 16"x32"	± 20 mm
YAI8	ang. int. costa lucida comp. 2/pz. 40x80 RT - 16"x32"	± 20 mm
YAE8	ang. est. costa lucida comp. 2/pz. 40x80 RT - 16"x32"	± 20 mm
GTL8	terminale "elle" c/profilo incollato 20x80 RT - 8"x32"	± 20 mm

Imballi

EMBALLAGE | VERPACKUNG | PACKING

STORY T_20

GRES PORCELLANATO | PORCELAIN TILE | GRÈS CÉRAME | FEINSTEINZEUG

	PZ/BOX	MQ/BOX	KG/BOX	BOX/PLT	MQ/PLT	KG/PLT	SPESSORE
80x80 RT	1	0,64	27,00	42	26,88	1146	20 mm
45x90 RT	2	0,81	35,00	27	21,87	960	20 mm
round	1	-	-	-	-	-	20 mm
round ang/int comp. 2 pz	1 comp.	-	-	-	-	-	20 mm
round ang/est comp. 2 pz	1 comp.	-	-	-	-	-	20 mm
term. ad "elle" c/prof. inc.	2	-	-	-	-	-	20 mm
griglia	1	-	-	-	-	-	20 mm
ang. griglia comp. 2 pz	1 comp.	-	-	-	-	-	20 mm
costa lucida	1	-	-	-	-	-	20 mm
ang/int costa lucida comp. 2 pz	1 comp.	-	-	-	-	-	20 mm
ang/est costa lucida comp. 2 pz	1 comp.	-	-	-	-	-	20 mm
Accessori T_20	pag. 354						
Pezzi speciali T_20	pag. 356						

Avvertenze e ulteriori informazioni sulla posa dei pavimenti T20 a pag. 348 di questo catalogo

Further information on the installation of T20 floors on page 348 of this catalogue

Pour d'ultérieures informations sur la pose des planchers T20, consultez la page 348 de ce catalogue

Weitere Informationen über die Verlegung von T20 finden Sie auf Seite 348 in diesem Katalog.

GRES PORCELLANATO | PORCELAIN TILE | GRÈS CÉRAME | FEINSTEINZEUG

EN 14411 Allegato G . Piastrelle di ceramica pressate a secco con basso assorbimento d'acqua (E ≤ 0,5%)

Gruppo B la

Caratteristiche tecniche Technical characteristics	Norma Norms	Valore Value
Resistenza all'abrasione profonda Abrasion resistance	ISO 10545-6	≤ 175 mm ³
Resistenza allo scivolamento Slip resistance	EN 16165 (previously DIN 51130)	R11
Resistenza allo scivolamento - Superfici bagnate a piedi scalzi Coefficient of friction - Dry surfaces walking on barefoot	EN 16165 (previously DIN 51097)	A+B+C
Resistenza allo scivolamento Dynamic coefficient of friction (DCOF)	ANSI A326.3	Conforme According to
Coefficiente di attrito dinamico Dynamic friction coefficient	METODO B.C.R.A.	Conforme According to
Grado di variazione cromatica Colour shade variation	V1 min - V4 max	V3

Per maggiori dettagli e aggiornamenti sulle certificazioni, consultare il nostro sito www.supergres.comFor further details and updated information on certifications, please visit our website www.supergres.comPour obtenir plus d'informations et de mises à jour sur les certifications, veuillez consulter notre site www.supergres.comFür weitere Details und Aktualisierungen der Zertifizierungen besuchen Sie bitte unsere Internetseite www.supergres.com

Travel T_20



TRAVEL T_20

GRES PORCELLANATO | PORCELAIN TILE | GRÈS CÉRAMÉ | FEINSTEINZEUG
EN 14411 Allegato G . Piastrelle di ceramica pressate a secco con basso assorbimento d'acqua (E ≤ 0,5%) | Gruppo B la



SOUTHGOLD T_20

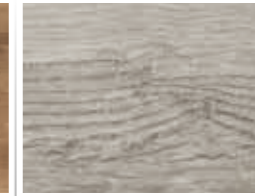

EASTGREY T_20



30x120 RT
R11 A+B+C
± 20 mm



SUPERFICIE STRUTTURATA | STRUCTURED SURFACE FINISH | FINITION STRUCTURÉE | STRUKTURIERTE OBERFLÄCHE

TRAVEL T_20

GRES PORCELLANATO | PORCELAIN TILE | GRÈS CÉRAME | FEINSTEINZEUG

SOUTHGOLD T_20



FINITURA STRUTTURATA R11 A+B+C T_20		
S3ØT	30x120 RT - 12"x48"	± 20 mm
PEZZI SPECIALI LATO 120		
SUR1	round 30x120 RT - 12"x48"	± 20 mm
SITR	round ang. interno comp. 2/pz. 30x120 RT - 12"x48"	± 20 mm
SETR	round ang. esterno comp. 2/pz. 30x120 RT - 12"x48"	± 20 mm
SCL3	costa lucida 30x120 RT - 12"x48"	± 20 mm
SICL	ang. int. costa lucida comp. 2/pz. 30x120 RT - 12"x48"	± 20 mm
SECL	ang. est. costa lucida comp. 2/pz. 30x120 RT - 12"x48"	± 20 mm
H1TL	terminale "elle" c/profilo incollato 20x120 RT - 8"x48"	± 20 mm

EASTGREY T_20



FINITURA STRUTTURATA R11 A+B+C T_20		
E3ØT	30x120 RT - 12"x48"	± 20 mm
PEZZI SPECIALI LATO 120		
ER3T	round 30x120 RT - 12"x48"	± 20 mm
ESIR	round ang. interno comp. 2/pz. 30x120 RT - 12"x48"	± 20 mm
EEAT	round ang. esterno comp. 2/pz. 30x120 RT - 12"x48"	± 20 mm
EACL	costa lucida 30x120 RT - 12"x48"	± 20 mm
EICU	ang. int. costa lucida comp. 2/pz. 30x120 RT - 12"x48"	± 20 mm
EEAC	ang. est. costa lucida comp. 2/pz. 30x120 RT - 12"x48"	± 20 mm
E1TL	terminale "elle" c/profilo incollato 20x120 RT - 8"x48"	± 20 mm

Imballi

EMBALLAGE | VERPACKUNG | PACKING

TRAVEL T_20

GRES PORCELLANATO | PORCELAIN TILE | GRÈS CÉRAME | FEINSTEINZEUG

	PZ/BOX	MQ/BOX	KG/BOX	BOX/PLT	MQ/PLT	KG/PLT	SPESSORE
30x120 RT	2	0,72	32,00	36	25,92	1167	20 mm
round	1	-	-	-	-	-	20 mm
round ang/int comp. 2 pz	1 comp.	-	-	-	-	-	20 mm
round ang/est comp. 2 pz	1 comp.	-	-	-	-	-	20 mm
term. ad "elle" c/prof. inc.	2	-	-	-	-	-	20 mm
costa lucida 30x120	1	-	-	-	-	-	20 mm
A/I costa lucida comp 2/pz	1 comp.	-	-	-	-	-	20 mm
A/E costa lucida comp 2/pz	1 comp.	-	-	-	-	-	20 mm
Accessori T_20	pag. 354						
Pezzi speciali T_20	pag. 356						

Avvertenze e ulteriori informazioni sulla posa dei pavimenti T20 a pag. 348 di questo catalogo

Further information on the installation of T20 floors on page 348 of this catalogue

Pour d'ultérieures informations sur la pose des planchers T20, consultez la page 348 de ce catalogue

Weitere Informationen über die Verlegung von T20 finden Sie auf Seite 348 in diesem Katalog.

GRES PORCELLANATO | PORCELAIN TILE | GRÈS CÉRAME | FEINSTEINZEUG

EN 14411 Allegato G . Piastrelle di ceramica pressate a secco con basso assorbimento d'acqua (E ≤ 0,5%)

Gruppo B Ia

Caratteristiche tecniche Technical characteristics	Norma Norms	Valore Value
Resistenza all'abrasione profonda Abrasion resistance	ISO 10545-6	≤ 175 mm ³
Resistenza allo scivolamento Slip resistance	UNI EN 16165 (previously DIN 51130)	R11
Resistenza allo scivolamento - Superfici bagnate a piedi scalzi Coefficient of friction - Dry surfaces walking on barefoot	UNI EN 16165 (previously DIN 51097)	A+B+C
Resistenza allo scivolamento Dynamic coefficient of friction (DCOF)	STANDARD ANSI A326.3-2017	Conforme According to
Coefficiente di attrito dinamico Dynamic friction coefficient	METODO B.C.R.A.	Conforme According to
Grado di variazione cromatica Colour shade variation	V1 min - V4 max	V4

Per maggiori dettagli e aggiornamenti sulle certificazioni, consultare il nostro sito www.supergres.comFor further details and updated information on certifications, please visit our website www.supergres.comPour obtenir plus d'informations et de mises à jour sur les certifications, veuillez consulter notre site www.supergres.comFür weitere Details und Aktualisierungen der Zertifizierungen besuchen Sie bitte unsere Internetseite www.supergres.com

WALK T_20



PAVIMENTO
 Avenue T_20 60x90 RT . 24"x36"
 Avenue T_20 Round 30x90 RT . 12"x36"
 Avenue T_20 Round ang.int. 30x90 RT . 12"x36"

WALK T_20

GRES PORCELLANATO | PORCELAIN TILE | GRÈS CÉRAMÉ | FEINSTEINZEUG
 EN 14411 Allegato G . Piastrelle di ceramica pressate a secco con basso assorbimento d'acqua (E ≤ 0,5%) | Gruppo B la

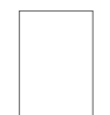

60x90 RT
 R11 A+B+C
 ÷ 20 mm



SUPERFICIE STRUTTURATA | STRUCTURED SURFACE FINISH | FINITION STRUCTURÉE | STRUKTURIERTE OBERFLÄCHE

WALK T_20

GRES PORCELLANATO | PORCELAIN TILE | GRÈS CÉRAME | FEINSTEINZEUG

AVENUE T_20



FINITURA STRUTTURATA R11 A+B+C		T_20	
WAV9	60x90 RT - 24"x36"		± 20 mm
PEZZI SPECIALI LATO 90			
WAR9	round 30x90 RT - 12"x36"		± 20 mm
AIRA	round ang. interno comp. 2/pz. 30x90 RT - 12"x36"		± 20 mm
WRAE	round ang. esterno comp. 2/pz. 30x90 RT - 12"x36"		± 20 mm
WKC9	costa lucida 30x90 RT - 12"x36"		± 20 mm
WCAI	ang. int. costa lucida comp. 2/pz. 30x90 RT - 12"x36"		± 20 mm
WCAE	ang. est. costa lucida comp. 2/pz. 30x90 RT - 12"x36"		± 20 mm
WAL9	terminale "elle" c/profilo incollato 20x90 RT - 8"x36"		± 20 mm

WAY T_20



FINITURA STRUTTURATA R11 A+B+C		T_20	
WWA9	60x90 RT - 24"x36"		± 20 mm
PEZZI SPECIALI LATO 90			
WAW9	round 30x90 RT - 12"x36"		± 20 mm
WWAR	round ang. interno comp. 2/pz. 30x90 RT - 12"x36"		± 20 mm
WAET	round ang. esterno comp. 2/pz. 30x90 RT - 12"x36"		± 20 mm
WWC9	costa lucida 30x90 RT - 12"x36"		± 20 mm
WAIC	ang. int. costa lucida comp. 2/pz. 30x90 RT - 12"x36"		± 20 mm
WAEC	ang. est. costa lucida comp. 2/pz. 30x90 RT - 12"x36"		± 20 mm
WWL9	terminale "elle" c/profilo incollato 20x90 RT - 8"x36"		± 20 mm

STREET T_20



FINITURA STRUTTURATA R11 A+B+C		T_20	
WST9	60x90 RT - 24"x36"		± 20 mm
PEZZI SPECIALI LATO 90			
WAS9	round 30x90 RT - 12"x36"		± 20 mm
WAIS	round ang. interno comp. 2/pz. 30x90 RT - 12"x36"		± 20 mm
WASE	round ang. esterno comp. 2/pz. 30x90 RT - 12"x36"		± 20 mm
WSC9	costa lucida 30x90 RT - 12"x36"		± 20 mm
SWAI	ang. int. costa lucida comp. 2/pz. 30x90 RT - 12"x36"		± 20 mm
SWAE	ang. est. costa lucida comp. 2/pz. 30x90 RT - 12"x36"		± 20 mm
WSL9	terminale "elle" c/profilo incollato 20x90 RT - 8"x36"		± 20 mm

Imballi

EMBALLAGE | VERPACKUNG | PACKING

WALK T_20

GRES PORCELLANATO | PORCELAIN TILE | GRÈS CÉRAME | FEINSTEINZEUG

	PZ/BOX	MQ/BOX	KG/BOX	BOX/PLT	MQ/PLT	KG/PLT	SPESSORE
60x90 RT	2	1,08	48,00	24	25,92	1167	20 mm
round	1	-	-	-	-	-	20 mm
round ang/int comp. 2 pz	1 comp.	-	-	-	-	-	20 mm
round ang/est comp. 2 pz	1 comp.	-	-	-	-	-	20 mm
term. ad "elle" c/prof. inc.	2	-	-	-	-	-	20 mm
costa lucida	1	-	-	-	-	-	20 mm
ang/int costa lucida comp. 2 pz	1 comp.	-	-	-	-	-	20 mm
ang/est costa lucida comp. 2 pz	1 comp.	-	-	-	-	-	20 mm
Accessori T_20	pag. 354						
Pezzi speciali T_20	pag. 356						

Avvertenze e ulteriori informazioni sulla posa dei pavimenti T20 a pag. 348 di questo catalogo

Further information on the installation of T20 floors on page 348 of this catalogue

Pour d'ultérieures informations sur la pose des planchers T20, consultez la page 348 de ce catalogue

Weitere Informationen über die Verlegung von T20 finden Sie auf Seite 348 in diesem Katalog.

GRES PORCELLANATO | PORCELAIN TILE | GRÈS CÉRAME | FEINSTEINZEUG

EN 14411 Allegato G . Piastrelle di ceramica pressate a secco con basso assorbimento d'acqua (E ≤ 0,5%)

Gruppo B la

Caratteristiche tecniche	Norma	Valore
Technical characteristics	Norms	Value
Resistenza all'abrasione profonda		
Abrasion resistance	ISO 10545-6	≤ 175 mm ³
Resistenza allo scivolamento		
Slip resistance	EN 16165 (previously DIN 51130)	R11
Resistenza allo scivolamento - Superfici bagnate a piedi scalzi		
Coefficient of friction - Dry surfaces walking on barefoot	EN 16165 (previously DIN 51097)	A+B+C
Resistenza allo scivolamento		
Dynamic coefficient of friction (DCOF)	ANSI A326.3	Conforme According to
Coefficiente di attrito dinamico		
Dynamic friction coefficient	METODO B.C.R.A.	Conforme According to
Grado di variazione cromatica		
Colour shade variation	V1 min - V4 max	Way V3 - Street V4 Avenue V4

Per maggiori dettagli e aggiornamenti sulle certificazioni, consultare il nostro sito www.supergres.comFor further details and updated information on certifications, please visit our website www.supergres.comPour obtenir plus d'informations et de mises à jour sur les certifications, veuillez consulter notre site www.supergres.comFür weitere Details und Aktualisierungen der Zertifizierungen besuchen Sie bitte unsere Internetseite www.supergres.com

Your Match T_20



Pearl T_20 80x80 RT - 32"x32"

YOUR MATCH T_20

GRES PORCELLANATO | PORCELAIN TILE | GRÈS CÉRAMÉ | FEINSTEINZEUG
EN 14411 Allegato G . Piastrelle di ceramica pressate a secco con basso assorbimento d'acqua (E ≤ 0,5%) | Gruppo B la



80x80 RT
R11 A+B+C
± 20 mm



SUPERFICIE STRUTTURATA | STRUCTURED SURFACE FINISH | FINITION STRUCTURÉE | STRUKTURIERTE OBERFLÄCHE

YOUR MATCH T_20

GRES PORCELLANATO | PORCELAIN TILE | GRÈS CÉRAMÉ | FEINSTEINZEUG

PEARL T_20



FINITURA STRUTTURATA R11 A+B+C T_20		
MPT8	80x80 RT - 32"x32"	± 20 mm
PEZZI SPECIALI LATO 80		
PRN8	round 40x80 RT - 16"x32"	± 20 mm
PAIR	round ang. interno comp. 2/pz. 40x80 RT - 16"x32"	± 20 mm
PAER	round ang. esterno comp. 2/pz. 40x80 RT - 16"x32"	± 20 mm
MPCL	costa lucida 40x80 RT - 16"x32"	± 20 mm
PEI8	ang. int. costa lucida comp. 2/pz. 40x80 RT - 16"x32"	± 20 mm
PEE8	ang. est. costa lucida comp. 2/pz. 40x80 RT - 16"x32"	± 20 mm
PEL8	terminale "elle" c/profilo incollato 20x80 RT - 8"x32"	± 20 mm

TAN T_20



FINITURA STRUTTURATA R11 A+B+C T_20		
MTNT	80x80 RT - 32"x32"	± 20 mm
PEZZI SPECIALI LATO 80		
TRN8	round 40x80 RT - 16"x32"	± 20 mm
TAIE	round ang. interno comp. 2/pz. 40x80 RT - 16"x32"	± 20 mm
TAE8	round ang. esterno comp. 2/pz. 40x80 RT - 16"x32"	± 20 mm
MTCL	costa lucida 40x80 RT - 16"x32"	± 20 mm
TAI8	ang. int. costa lucida comp. 2/pz. 40x80 RT - 16"x32"	± 20 mm
TAE8	ang. est. costa lucida comp. 2/pz. 40x80 RT - 16"x32"	± 20 mm
TNL8	terminale "elle" c/profilo incollato 20x80 RT - 8"x32"	± 20 mm

DARK T_20



FINITURA STRUTTURATA R11 A+B+C T_20		
MDKT	80x80 RT - 32"x32"	± 20 mm
PEZZI SPECIALI LATO 80		
DRN8	round 40x80 RT - 16"x32"	± 20 mm
DAIR	round ang. interno comp. 2/pz. 40x80 RT - 16"x32"	± 20 mm
DAER	round ang. esterno comp. 2/pz. 40x80 RT - 16"x32"	± 20 mm
MKCL	costa lucida 40x80 RT - 16"x32"	± 20 mm
DAI8	ang. int. costa lucida comp. 2/pz. 40x80 RT - 16"x32"	± 20 mm
DAE8	ang. est. costa lucida comp. 2/pz. 40x80 RT - 16"x32"	± 20 mm
DKL8	terminale "elle" c/profilo incollato 20x80 RT - 8"x32"	± 20 mm

Imballi

EMBALLAGE | VERPACKUNG | PACKING

YOUR MATCH T_20

GRES PORCELLANATO | PORCELAIN TILE | GRÈS CÉRAMÉ | FEINSTEINZEUG

	PZ/BOX	MQ/BOX	KG/BOX	BOX/PLT	MQ/PLT	KG/PLT	SPESSORE
80x80 RT	1	0,64	27,00	42	26,88	1146	20 mm
round	1	-	-	-	-	-	20 mm
round ang/int comp. 2 pz	1 comp.	-	-	-	-	-	20 mm
round ang/est comp. 2 pz	1 comp.	-	-	-	-	-	20 mm
costa lucida	1	-	-	-	-	-	20 mm
costa lucida ang/int comp. 2 pz	1 comp.	-	-	-	-	-	20 mm
costa lucida ang/est comp. 2 pz	1 comp.	-	-	-	-	-	20 mm
term. ad "elle" c/prof. inc.	2	-	-	-	-	-	20 mm
Accessori T_20	pag. 354						
Pezzi speciali T_20	pag. 356						

Avvertenze e ulteriori informazioni sulla posa dei pavimenti T20 a pag. 348 di questo catalogo

Further information on the installation of T20 floors on page 348 of this catalogue

Pour d'ultérieures informations sur la pose des planchers T20, consultez la page 348 de ce catalogue

Weitere Informationen über die Verlegung von T20 finden Sie auf Seite 348 in diesem Katalog.

FOG T_20



FINITURA STRUTTURATA R11 A+B+C T_20		
MFGT	80x80 RT - 32"x32"	± 20 mm
PEZZI SPECIALI LATO 80		
FRN8	round 40x80 RT - 16"x32"	± 20 mm
FAIR	round ang. interno comp. 2/pz. 40x80 RT - 16"x32"	± 20 mm
FGER	round ang. esterno comp. 2/pz. 40x80 RT - 16"x32"	± 20 mm
MFCL	costa lucida 40x80 RT - 16"x32"	± 20 mm
FAI8	ang. int. costa lucida comp. 2/pz. 40x80 RT - 16"x32"	± 20 mm
FAE8	ang. est. costa lucida comp. 2/pz. 40x80 RT - 16"x32"	± 20 mm
FGL8	terminale "elle" c/profilo incollato 20x80 RT - 8"x32"	± 20 mm

GRES PORCELLANATO | PORCELAIN TILE | GRÈS CÉRAMÉ | FEINSTEINZEUG

EN 14411 Allegato G . Piastrelle di ceramica pressate a secco con basso assorbimento d'acqua (E ≤ 0,5%)

Gruppo B Ia

Caratteristiche tecniche Technical characteristics	Norma Norms	Valore Value
Resistenza all'abrasione profonda Abrasion resistance	ISO 10545-6	≤ 175 mm³
Resistenza allo scivolamento Slip resistance	EN 16165 (previously DIN 51130)	R11
Resistenza allo scivolamento - Superfici bagnate a piedi scalzi Coefficient of friction - Dry surfaces walking on barefoot	EN 16165 (previously DIN 51097)	A+B+C
Resistenza allo scivolamento Dynamic coefficient of friction (DCOF)	ANSI A326.3	Conforme According to
Coefficiente di attrito dinamico Dynamic friction coefficient	METODO B.C.R.A.	Conforme According to
Grado di variazione cromatica Colour shade variation	V1 min - V4 max	V3

Per maggiori dettagli e aggiornamenti sulle certificazioni, consultare il nostro sito www.supergres.comFor further details and updated information on certifications, please visit our website www.supergres.comPour obtenir plus d'informations et de mises à jour sur les certifications, veuillez consulter notre site www.supergres.comFür weitere Details und Aktualisierungen der Zertifizierungen besuchen Sie bitte unsere Internetseite www.supergres.com

IL RISPETTO PER L'AMBIENTE ECO-SUSTAINABILITY



PUNTIAMO A UNO SVILUPPO ECO-SOSTENIBILE

PEF (Product Environmental Footprint)

Introdotta dall'Unione Europea, la PEF è una dichiarazione di conformità del prodotto a determinati criteri ambientali certificati. È una dichiarazione delle performance ambientali del prodotto relative all'intero ciclo di vita. Il gruppo Concorde è il primo gruppo ceramico a livello europeo ad aver realizzato le PEF per i prodotti di ogni suo marchio. Le PEF sono state certificate dal DNV.

FDES (Fiches de Déclaration Environnementale et Sanitaire)

Questa dichiarazione riguarda esclusivamente il mercato francese e attesta la conformità dei prodotti di Ceramiche Supergres a determinati indicatori e valori di carattere ambientale e sanitario. Nel mercato francese le FDES sono molto utilizzate da architetti e dai direttori dei lavori, durante la fase di selezione dei materiali.

HPD (Health Product Declaration)

Ceramiche Supergres dispone di questa autodichiarazione, diffusa nel mercato americano, che attesta le caratteristiche di ecosostenibilità del prodotto finito.

NOUS MISONS SUR UN DÉVELOPPEMENT ÉCO-DURABLE.

PEF (Product Environmental Footprint)

Introduite par l'Union Européenne, la PEF est une déclaration de conformité du produit à certains critères environnementaux certifiés. C'est une déclaration des performances environnementales du produit relatives à tout le cycle de vie. Le groupe Concorde est le premier groupe céramique à l'échelle européenne à avoir réalisé les PEF pour les produits de chacune de ses marques. Les PEF ont été certifiées par le DNV.

FDES (Fiches de Déclaration Environnementale et Sanitaire)

Cette déclaration concerne exclusivement le marché français et atteste la conformité des produits de Ceramiche Supergres à certains indicateurs et valeurs de caractère environnemental et sanitaire. Sur le marché français, les FDES sont très utilisées par les architectes et par les directeurs des travaux, durant la phase de sélection des matériaux.

HPD (Health Product Declaration)

Ceramiche Supergres dispose de cette auto-déclaration, diffuse sur le marché américain, qui atteste les caractéristiques d'éco-durabilité du produit fini.

WE AIM TO ACHIEVE ECO-SUSTAINABLE DEVELOPMENT

PEF (Product Environmental Footprint)

Introduced by the European Union, PEF is a declaration of conformity of a product in compliance with certain given certified environmental criteria. It is a declaration of the environmental performances of a product in relation to its entire life-cycle. The Concorde Group was the first ceramic company in Europe to adopt PEF for the products of every single one of its brand names. The PEF methods have been certified by the DNV.

FDES (Fiches de Déclaration Environnementale et Sanitaire)

This declaration relates exclusively to the French market and certifies the compliance of Ceramiche Supergres products to certain environmental and health indicators. FDES regulations are very popular among architects and construction managers in the French market during the selection phase of the materials.

HPD (Health Product Declaration)

Ceramiche Supergres adopts this self-declaration, widespread on the American market, which certifies the features of eco-sustainability of a finished product.

WIR SETZEN AUF EINE UMWELTSCHÜTZENDE UND NACHHALTIGE ENTWICKLUNG.

PEF (Product Environmental Footprint)

Die von der Europäischen Union eingeführte PEF ist eine Deklaration über die Einhaltung bestimmter zertifizierter Umweltkriterien. PEF ist Deklaration über die Umweltverträglichkeit eines Produkts während seines gesamten Lebenszyklus. Die Concorde-Gruppe ist die erste Keramikgruppe auf europäischer Ebene, die für jedes Produkt ihrer Marke über eine PEF verfügt. Die PEFs wurden vom DNV zertifiziert.

FDES (Fiches de Déclaration Environnementale et Sanitaire)

Diese Deklaration bezieht sich nur auf den französischen Markt und bescheinigt die Konformität der Produkte von Ceramiche Supergres in Bezug auf ganz bestimmte Indikatoren und Umwelts- und Gesundheitswerte. Auf dem französischen Markt werden die FDES von Architekten und Bauleitern bei der Auswahl der Materialien häufig verwendet.

HPD (Health Product Declaration)

Ceramiche Supergres verfügt über diese, auf dem amerikanischen Markt weit verbreitete Selbstdenkulation, die die Nachhaltigkeit des fertigen Produkts bescheinigt.

PUNTIAMO A UNO SVILUPPO ECO-SOSTENIBILE

LEED

Ceramiche Supergres, da sempre molto sensibile alle tematiche dell'edilizia sostenibile, realizza prodotti che consentono di concorrere all'ottenimento di punteggi LEED (Leadership in Energy and Environmental Design), il sistema di parametri nato negli Stati Uniti per valutare l'eco-sostenibilità degli edifici. Questo sistema è il più adottato negli USA e si sta diffondendo in oltre 40 Paesi del mondo. Si basa sull'assegnazione di punteggi funzionali a valutare l'eco-sostenibilità di un edificio: dal recupero dell'acqua al risparmio energetico, dall'utilizzo di materiali da costruzione realizzati con materie riciclate al comfort degli spazi. Sempre più gli enti pubblici, nella realizzazione degli edifici e nella determinazione dei vincoli all'interno dei piani casa che deliberano, richiedono l'utilizzo di prodotti in grado di fornire crediti LEED per meglio favorire lo sviluppo di un'architettura eco-sostenibile.

In quest'ottica, i prodotti di Ceramiche Supergres, grazie alle proprie caratteristiche ecosostenibili ed alle elevate quantità di materiali di riciclo utilizzate nell'impatto del gres porcellanato, contribuiscono ad aumentare il punteggio LEED degli edifici in cui vengono impiegati, nei seguenti ambiti: materiali e risorse, siti sostenibili, trasparenza e ottimizzazione, ecc (vedi tabella "Crediti Leed" riportata di seguito).

LEED V4.1

FINALITÀ	REQUISITI	PRODOTTI SUPERGRES	CREDITI
SITI SOSTENIBILI (SS)			
Ridurre al minimo gli effetti isola di calore sul microclima e sull'habitat.	Riduzione dell'effetto isola di calore	Le piastrelle di colore chiaro della gamma Supergres, utilizzate in spazi esterni, contribuiscono a ridurre l'effetto isola di calore (differenza di gradiente termico tra aree urbane e extraurbane) per ridurre al minimo l'impatto sul microclima. Tutto ciò grazie agli alti valori di coefficiente di riflettanza solare SRI dei prodotti Supergres.	Riduzione dell'effetto isola di calore - Non tetto (pavimentazione esterna) - Tetto (ad eccezione di Healthcare che dà 1 punto) 2
MATERIALI E RISORSE (MR)			
Impegnarsi ad utilizzare prodotti e materiali con un basso impatto ambientale, economico e sociale e per i quali sono disponibili informazioni sull'intero ciclo di vita.	DISPONIBILITÀ DI EPD CERTIFICATA. L'EPD rappresenta una sorta di carta d'identità dei prodotti e ne descrive l'impatto sull'ambiente durante tutte le fasi del ciclo di vita: dalla fase di estrazione delle materie prime, fino allo smaltimento. FONTE DI MATERIE PRIME E SEGNALAZIONE DI ESTRAZIONE. Utilizzare prodotti provenienti da almeno tre diversi produttori, che rispettano almeno uno dei criteri riportati, per almeno il 20% in costo, del valore totale dei prodotti da costruzione installati in modo permanente nel progetto. (1 punto) Utilizzare prodotti provenienti da almeno cinque diversi produttori, che rispettano almeno uno dei criteri riportati, per almeno il 40% in costo, del valore totale dei prodotti da costruzione installati in modo permanente nel progetto. (2 punti) Contenuto di materiale riciclato. Prodotti che rispettano il requisito del contenuto di materiale riciclato sono valutati al 100% del loro costo per il calcolo del raggiungimento del credito. - Il contenuto di materiale riciclato è dato dalla somma del contenuto di riciclato "post-consumer" + ½ del contenuto di riciclato pre-consumer, basato sul peso. - Il contenuto di riciclato va poi moltiplicato per il costo, per determinare il contenuto complessivo di riciclato.	Supergres dispone di una EPD certificata da un ente esterno indipendente.	Trasparenza ed ottimizzazione dei prodotti per l'edificio - EPD - Dichiarazione ambientale di prodotto. 1
Verifica della minimizzazione dell'uso e della generazione di sostanze nocive.	TRASPARENZA NELL'USO DEI MATERIALI. Opzione 1. Report degli ingredienti dei materiali. Utilizzare prodotti installati in modo permanente che utilizzano uno dei seguenti programmi per l'inventario chimico del prodotto, per sostanze con concentrazione maggiore o uguale a 0,1% (1000 ppm). Declare: l'etichetta Declare dovrà rispondere ai seguenti requisiti: - Rispondere al requisito "Red List Free" oppure "Declared". - Essere conforme ad LBC (Living Building Challenge) e dimostrare un inventario fino allo 0,1% (1000 ppm). Opzione 2. Ingredienti dei materiali - ottimizzazione (1 punto). Inventario e verifica avanzati (valutato al 100% del costo, oppure 1 prodotto). - Etichetta "Declare" valutata come "Red list Free", verificata da ente indipendente di terza parte. - Percorso Internazionale Alternativo - REACH Optimization. (valutato al 100% del costo, oppure 1 prodotto).	Questo credito si applica ai prodotti elencati nell'appendice 1 del certificato DNV, disponibile in azienda	Trasparenza ed ottimizzazione dei prodotti per l'edificio - Fonte delle materie prime 1-2
		Supergres dispone dell' etichetta Declare in corso di validità; le affermazioni contenute in tale dichiarazione sono sostenute da elementi oggettivi.	Trasparenza ed ottimizzazione prodotti per l'edificio - ingredienti dei materiali 1
		Supergres non utilizza per la realizzazione dei propri prodotti sostanze appartenenti alla lista Reach o inserite nella Candidate List.	1
QUALITÀ AMBIENTALE INTERNA (IEQ)			
Riguarda l'emissione di composti organici volatili (VOC) nell'aria indoor e i VOC contenuti nei materiali, così come le metodologie di test secondo le quali le emissioni di VOC all'interno dell'edificio sono misurate. Materiali diversi devono essere conformi a diversi requisiti per essere considerati conformi a questo credito.	Ridurre la concentrazione di contaminanti chimici che possano compromettere la qualità dell'aria, la salubrità, la produttività e l'ambiente. Prodotti che rispondono a tale requisito (pietra, ceramica, metallo, vetro, cemento, mattoni di argilla, etc) sono considerati completamente conformi senza necessità di condurre alcun tipo di test	I prodotti Supergres non rilasciano alcuna sostanza organica volatile nell'ambiente (VOC - volatile organic compounds).	Materiali basso - emissivi 1-3

WE AIM TO ACHIEVE ECO-SUSTAINABLE DEVELOPMENT

LEED

Ceramiche Supergres, has always been extremely focused when it comes to sustainable building issues, creating products that are able to achieve LEED (Leadership in Energy and Environmental Design) points, the system of parameters created in the United States to measure the eco-sustainability of buildings. This is the most used system in the USA and is now starting to be adopted in over 40 countries across the world. It is based on the award of points to access the eco-sustainability of a building: from water recycling and energy saving to the use of building material created using recycled materials all the way through to the comfort of the space. Public bodies are becoming increasingly committed to insisting that materials that achieve LEED credits are used during construction of new buildings, to better promote the development of eco-sustainable architecture.

In light of this, thanks to the eco-sustainable features and high qualities of the recycled material used in the body of the porcelain stoneware, Ceramiche Supergres products contribute to increasing the LEED scores of a building they are used in, in the following areas: materials and resources, sustainable sites, transparency and optimization etc. (see chart "LEED Credits" that follows).

LEED V4.1

OBJECTIVES	REQUISITES	SUPERGRES PRODUCTS	CREDITS
SUSTAINABLE SITES (SS)			
To reduce the influence of the heat island effect on the microclimate and natural habitats to the absolute minimum.	Heat island effect reduction	The light-colored tiles of the Supergres range, used in outdoor areas, help reduce the heat island effect (the thermal gradient difference between urban and suburban areas) to minimize the impact on the microclimate. All thanks to the high values of solar reflectance coefficient of Supergres SRI products.	Heat island effect reduction - Not roofs (exterior paving) - Roofs (with the exception of Healthcare that gives 1 point) 2
MATERIALS AND RESOURCES (MR)			
Commit to using products and materials with low environmental, economic and social impact and for which information is available on the entire life cycle.	CERTIFIED EPD AVAILABLE. EPD can be thought of as a virtual identity card for products and describes their impact on the environment during all stages of the life cycle: from extraction of raw materials to their disposal. RESPONSIBLE SOURCING OF RAW MATERIALS. Use products sourced from at least three different manufacturers that meet at least one of the responsible sourcing and extraction criteria below for at least 20%, by cost, of the total value of permanently installed building products in the project. (1 point). Use products sourced from at least five different manufacturers that meet at least one of the responsible sourcing and extraction criteria below for at least 40%, by cost, of the total value of permanently installed building products in the project (2 points). Recycled content. Products meeting recycled content criteria are valued at 100% of their cost for the purposes of credit achievement calculation. - Recycled content is the sum of postconsumer recycled content plus one-half the preconsumer recycled content, based on weight. - The recycled fraction of the assembly is then multiplied by the cost of assembly to determine the recycled content value.	Supergres has an EPD certified by an independent external body.	Building product disclosure and optimization - EPD - Environmental product declaration. 1
Verification on to minimization of the use and generation of harmful substances.	TRANSPARENCY IN THE USE OF MATERIALS. Option 1. Material ingredient reporting. Use permanently installed products that use any of the following programs to demonstrate the chemical inventory of the product to at least 0.1% (1000 ppm). Declare : the Declare product label must meet the following requirements: - Declare labels designated as Red List Free or Declared. - Declare labels designated as LBC Compliant that demonstrate content inventory to 0.1% (1000 ppm). Option 2. Material ingredient optimization (1 point) Advanced Inventory & Assessment (value at 100% by cost or 1 product): - Declare labels designated as Red List Free that are third-party verified. - International Alternative Compliance Path - REACH Optimization (value at 100% of cost or 1 product).	This credit is applicable for products listed in the appendix 1 of DNV Certificate available in the company. Supergres has the Declare product label; the statements contained in this declaration are supported by evidences. Supergres does not use substances belonging to the Reach or Candidate list for the manufacturing of its products.	Building product disclosure and optimization - material ingredients. 1 1
INDOOR ENVIRONMENTAL QUALITY (IEQ)			
It covers volatile organic compound (VOC) emissions into indoor air and the VOC content of materials, as well as the testing methods by which indoor emissions are determined. Different materials must meet different requirements to be considered compliant for this credit.	To reduce the concentrations of chemical contaminants that can damage air quality, human health, productivity, and the environment. Products that are an inherently nonemitting sources of VOCs (stone, ceramic, powder-coated metals, plated or anodized metal, glass, concrete, clay brick, and unfinished or untreated solid wood flooring) are considered fully compliant without any VOC emissions testing.	Supergres products do not release any volatile organic substances (VOC) into the environment.	Low - emitting materials 1-3

Nous misons sur un développement éco-durable.

LEED

Ceramiche Supergres, toujours très sensible aux thèmes de la construction durable, réalise des produits qui permettent de participer à l'obtention des points LEED (Leadership in Energy and Environmental Design), le système de paramètres né aux États-Unis pour évaluer l'éco-durabilité des bâtiments. Ce système est le plus adopté aux États-Unis et commence à se diffuser dans plus de 40 Pays du monde entier. Il est basé sur l'attribution de points fonctionnels, destinés à évaluer l'éco-durabilité d'un bâtiment : à partir de la récupération de l'eau jusqu'à l'économie d'énergie, ou de l'utilisation de matériaux de construction réalisés avec des matières recyclées jusqu'au confort des espaces. De plus en plus d'organismes publics, lors la réalisation des bâtiments et les déterminations des contraintes dans les plans de maisons qu'ils délibèrent, exigent l'utilisation de produits susceptibles de fournir crédits LEED afin de favoriser au mieux le développement d'une architecture éco-durable.

Dans cette optique, les produits de Ceramiche Supergres, grâce à leurs propres caractéristiques éco-durables et aux quantités élevées de matériaux de recyclage utilisées dans la pâte du grès cérame, contribuent à augmenter les points LEED des bâtiments dans lesquels ils sont utilisés, dans les domaines suivants : matériaux et ressources, sites durables, transparence, et optimisation, etc. (voir le tableau « Credits Leed » indiqué ci-après).

LEED V4.1

FINALITÉ	EXIGENCES	PRODUITS SUPERGRÈS	CRÉDITS
SUSTAINABLE SITES (SS)			
Réduire au minimum les effets d'îlot de chaleur sur le microclimat et sur l'habitat.	Réduction de l'effet îlot de chaleur	Les carreaux de couleur claire de la gamme Supergres, utilisés dans des espaces extérieurs, contribuent à réduire l'effet îlot de chaleur (différence de gradient thermique entre les zones urbaines et extra-urbaines) pour réduire au minimum l'impact sur le microclimat. Tout cela grâce aux valeurs élevées de coefficient de réflectance solaire SRI des produits Supergres.	Réduction de l'effet îlot de chaleur - Toit exclu (revêtement de sol extérieur) - Toit (sauf Healthcare qui donne 1 point) 2

MATÉRIAUX ET RESSOURCES (MR)

S'engager à utiliser des produits et des matériaux à faible impact environnemental, économique et social, et pour lesquels sont disponibles des informations sur tout le cycle de vie	DISPONIBILITÉ D'UNE EPD CERTIFIÉE. L'EPD représente une sorte de carte d'identité des produits et en décrit l'impact sur l'environnement durant toutes les phases du cycle de vie : à partir de la phase d'extraction des matières premières jusqu'à l'élimination..	Supergres dispose d'une EPD certifiée par un organisme étranger indépendant.	Transparence et optimisation des produits pour le bâtiment - EPD - Déclaration environnementale du produit. 1
	SOURCE DES MATIÈRES PREMIÈRES ET DÉCLARATION D'EXTRACTION. Utiliser des produits provenant d'au moins trois producteurs différents, qui respectent au moins l'un des critères indiqués, pour au moins 20 % du coût, de la valeur totale des produits de construction posés de façon permanente dans le cadre du projet. (1 point) Utiliser des produits provenant d'au moins trois producteurs différents, qui respectent au moins l'un des critères indiqués, pour au moins 40 % du coût, de la valeur totale des produits de construction posés de façon permanente dans le cadre du projet. (2 points) Teneur en matériaux recyclés. Les produits qui respectent la teneur en matériaux recyclés tel que requis sont évalués à 100 % de leur coût pour le calcul du crédit. - La teneur en matériaux recyclés est calculée en additionnant la teneur en matériaux recyclés « post-consommation » + 1/2 de la teneur en matériaux recyclés « pré-consommation », exprimée en poids. - La teneur en matériaux recyclés est ensuite multipliée par le coût pour déterminer la teneur globale en matériaux recyclés.	Ce crédit s'applique aux produits répertoriés dans l'annexe 1 de la certification DNV disponible dans l'entreprise	Transparence et optimisation des produits pour le bâtiment - Source des matières premières 1-2
Vérification de la production et utilisation minimales de substances nocives.	TRANSPARENCE DE L'UTILISATION DES MATÉRIAUX. Option 1. Compte-rendu de la composition des matériaux. Utiliser des produits installés de manière permanente qui utilisent l'un des programmes suivants pour l'inventaire de la composition chimique du produit, pour les substances dont la concentration est supérieure ou égale à 0,1 % (1000 ppm). Declare : le label Declare doit répondre aux exigences suivantes : - Être conforme à l'exigence « Red List Free » ou « Declared ». - Être conforme au LBC (Living Building Challenge) et démontrer une composition jusqu'à 0,1 % (1000 ppm). Option 2. Composition des matériaux - optimisation (1 point) : Inventaire (évalué à 100 % du coût ou bien 1 produit) et vérification avancées. - Le label « Declare » évalué comme « Red list Free », vérifié par un institut tiers indépendant. - Parcours international alternatif - Optimisation REACH. (évalué à 100 % du coût ou bien 1 produit).	Supergres dispose du label Declare en cours de validité ; les affirmations contenues dans cette déclaration sont supportées par des éléments objectifs. Pour produire ses produits Supergres n'utilise pas de substances appartenant à la liste Reach ou incluses dans la Candidate Liste.	Transparence et optimisation des produits pour le bâtiment - Composition des matériaux 1 1

QUALITÉ ENVIRONNEMENTALE INTERNE (IEQ)

Concerner les émissions de composés organiques volatils (COV) dans l'air intérieur, les COV contenus dans les matériaux et les méthodes utilisées pour mesurer les émissions de COV à l'intérieur du bâtiment. Des matériaux différents doivent chacun être conformes à des exigences particulières pour être considérés comme étant conformes à ce crédit.	Réduire la concentration de contaminants chimiques pouvant compromettre la qualité de l'air, la santé, la productivité et l'environnement. Les produits qui répondent à cette exigence (pierre, céramique, métal, verre, béton, briques en argile, etc.) sont considérés comme entièrement conformes, et ne nécessitent pas de tests supplémentaires.	Les produits Supergres ne dégagent pas de substance organique volatile dans l'environnement (VOC - volatile organic compounds).	Matériaux à faible émissivité 1-3
---	---	---	-----------------------------------

Wir setzen auf eine umweltschützende und nachhaltige Entwicklung.

LEED

Ceramiche Supergres, schon immer aufmerksam gegenüber Umweltfragen und Nachhaltigkeit, stellt Produkte her, die zum Erhalt von LEED Punkten (Leadership in Energy and Environmental Design) beitragen, einem Parametersystem aus den USA, das die ökologische Nachhaltigkeit von Gebäuden bewertet. Dieses System ist am meisten in den USA verbreitet, etabliert sich aber gerade auch in über 40 Ländern weltweit. Dabei werden Punkte vergeben, die die ökologische Nachhaltigkeit eines Gebäudes beurteilen: in Bezug auf die Wasserwirtschaft, den Energiebedarf, die Verwendung von Baustoffen, die aus recycelten Materialien hergestellt werden und die Qualität des Raumklimas. Immer öffentliche Einrichtungen verlangen beim Bau der Gebäude und bei der Ermittlung der Einschränkungen bei der Hausprojektierung bewusst die Verwendung von Produkten, die zum Erhalt von LEED Punkten beitragen, um die Entwicklung nachhaltiger Öko-Architektur zu fördern.

Vor diesem Hintergrund tragen die Produkte von Ceramiche Supergres, dank ihrer umweltfreundlichen Eigenschaften und dem hohen Anteil an recycelten Materialien in der Feinstezeugmasse, dazu bei, die LEED Punktezahl der Gebäude, in denen sie verwendet werden, zu erhöhen und zwar in den folgenden Kategorien: Materialien und Ressourcen, nachhaltige Standorte, Transparenz und Optimierung, etc. (siehe nachfolgende Tabelle "Leed Credits").

LEED V4.1

ZWECK	REQUISITES	SUPERGRES PRODUCTS	CREDITS
NACHHALTIGE STANDORTE (SS)			
Die Auswirkungen des Wärmeinseleffektes auf das Mikroklima und auf die Lebensräume minimieren.	Reduzierung des Wärmeinseleffektes	Die hellen Fliesen von Supergres, die im Außenbereich verwendet werden, tragen dazu bei, den Wärmeinseleffekt (der Temperaturunterschied zwischen städtischen und ländlichen Bereichen) zu reduzieren und die Auswirkungen auf das Mikroklima zu minimieren. Dies alles, dank der hohen Werte des Sonnenreflexionskoeffizienten SRI der Supergres Produkte.	Reduzierung des Wärmeinseleffektes - Kein Dach (Bodenbelag im Außenbereich) - Dach (mit Ausnahme von Healthcare, mit dem man 1 Punkt verdient) 2

MATERIALIEN UND RESSOURCEN (MR)

Verpflichtung Produkte und Materialien mit geringer Umweltbelastung sowie wirtschaftlichen und sozialen Belastung zu verwenden, für die Informationen über den gesamten Lebenszyklus zur Verfügung stehen.	VERFÜGBARKEIT VON ZERTIFIZIERTER EPD (UMWELTPRODUKTDEKLARATION) Die EPD ist eine Art Personalausweis der Produkte und beschreibt die Auswirkungen auf die Umwelt in allen Phasen des Lebenszyklus: Von der Gewinnung der Rohstoffe bis hin zur Entsorgung.	Supergres verfügt über eine EPD (Umweltproduktdeklaration), die von einer externen Stelle zertifiziert wurde.	Transparenz und Optimierung der Produkte für das Gebäude - EPD - Umwelt-Produktdeklaration. 1
	URSPRUNG DER ROHSTOFFE UND BERICHTERSTATTUNG ÜBER DIE GEWINNUNG. Verwendung von Produkten von mindestens drei verschiedenen Herstellern, die mindestens eines der oben genannten Kriterien erfüllen, für mindestens 20 % der Kosten des Gesamtwerts der im Projekt dauerhaft installierten Bauprodukte. (1 Punkt) Verwendung von Produkten von mindestens fünf verschiedenen Herstellern, die mindestens eines der oben genannten Kriterien erfüllen, für mindestens 40 % der Kosten des Gesamtwerts der im Projekt dauerhaft installierten Bauprodukte. (2 Punkte) Inhalt von Recyclingmaterial Produkte, die die Anforderungen an den Recyclinganteil erfüllen, werden bei der Berechnung der Kredite mit 100 % ihrer Kosten bewertet. - Der Recyclinganteil ergibt sich aus der Summe des Post-Consumer-Recyclinganteils + die Hälfte des Pre-Consumer-Recyclinganteils, basierend auf dem Gewicht. - Der Recyclinganteil wird dann mit den Kosten multipliziert, um den gesamten Recyclinganteil zu berechnen.	Dieser Kredit gilt für die in Anhang 1 des DNV-Zertifikats aufgeführten Produkte; das Zertifikat ist beim Unternehmen erhältlich	Transparenz und Optimierung der Produkte für das Gebäude - Herkunft der Rohstoffe 1-2
Kontrolle der Minimierung der Verwendung und Erzeugung von Schadstoffen.	TRANSPARENZ BEI DER VERWENDUNG VON MATERIALIEN. Option 1. Bericht über die Zusammensetzung der Materialien. Fest installierte Produkte verwenden, die eines der folgenden Programme für die Bestandsaufnahme von Chemikalien für Stoffe mit einer Konzentration von 0,1 % oder mehr (1000 ppm) verwenden. Declare: Das Declare-Etikett muss die folgenden Anforderungen erfüllen: - Anforderungen gemäß „Red List Free“ oder „Declared“. - Anforderungen gemäß LBC (Living Building Challenge) mit Nachweis eines Inventars bis zu 0,1% (1000 ppm). Option 2. Zusammensetzung der Materialien - Optimierung (1 Punkt): Erweiterte Bestandsaufnahme und Überprüfung (bewertet mit 100% der Kosten oder 1 Produkt). - Declare-Etikett mit Bewertung als „Red list Free“ von unabhängigen Dritten überprüft. - Internationaler Alternativweg - REACH-Optimierung. (bewertet mit 100% der Kosten oder 1 Produkt).	Supergres ist mit dem gültigen Declare-Etikett versehen; die Aussagen in dieser Erklärung werden durch objektive Beweise gestützt. Supergres verwendet bei der Herstellung seiner Produkte keine Stoffe aus der Reach- oder der Candidate-Liste.	Transparenz und Optimierung der Produkte für das Gebäude - Zusammensetzung der Materialien 1 1

INNENRAUMQUALITÄT (IEQ)

Betrifft die Emission flüchtiger organischer Verbindungen (VOC) in der Innenraumluft und die in Materialien enthaltenen VOC sowie die Prüfverfahren, mit denen die VOC-Emissionen in Innenräumen gemessen werden. Verschiedene Materialien müssen unterschiedliche Anforderungen erfüllen, um für diesen Kredit zu gelten.	Verringerung der Konzentration chemischer Schadstoffe, die die Luftqualität, die Gesundheit, die Produktivität und die Umwelt beeinträchtigen können. Produkte, die diese Anforderung erfüllen (Stein, Keramik, Metall, Glas, Beton, Tonziegel usw.), gelten als vollständig konform, ohne dass eine Prüfung erforderlich ist.	Die Supergres Produkte setzen keine flüchtigen organischen Stoffe (VOC - volatile organic compounds) frei, die negative Auswirkungen auf die Umwelt haben.	Emissionsarme Materialien 1-3
--	--	--	-------------------------------

DECLARE L'ETICHETTA PER LA TRASPARENZA DEI MATERIALI DA COSTRUZIONE

Sempre attenta ai temi della sostenibilità, Supergres ha deciso di adottare l'etichetta **Declare** che comunica ai progettisti, al consumatore finale e alle imprese da dove viene il prodotto, come è composto e come può essere smaltito al termine del suo ciclo di vita.

Nata con questo intento di **trasparenza**, l'etichetta Declare è gestita dall'International Living Future Institute, ILFI, un'organizzazione no profit impegnata per la diffusione di una sensibilità ecologica nel comparto edilizio, finalizzata alla costruzione di edifici realizzati utilizzando materiali "sani", che assicurano la **salubrità degli spazi** in cui si vive quotidianamente.

Ogni prodotto che vanta l'etichetta Declare, dichiara che al suo interno non sono presenti "ingredienti" che rientrano della Red List, ovvero l'elenco dei materiali inquinanti più dannosi dell'industria delle costruzioni.

Questa lista, redatta e aggiornata direttamente dall'ILFI, segnala le sostanze che inquinano l'ambiente, e che costituiscono un danno per la salute per chi li produce, e per gli utilizzatori finali a seguito dell'esposizione prolungata.

Un database di prodotti in costante aggiornamento che aiuta gli utenti finali, ma soprattutto i progettisti e i costruttori a **identificare i materiali da costruzioni migliori per l'ambiente** e per le persone.

<https://declare.living-future.org/>

The label for construction material transparency

With its eyes permanently trained on the issue of sustainability, Supergres has decided to adopt the **Declare** label, which communicates to designers, end consumers and companies the origin of the product, what it is made of and how it can be disposed of at the end of its life cycle.

Launched with this specific intention of conveying **transparency**, the Declare label is managed by the International Living Future Institute, ILFI, a non-profit organisation engaged in disseminating environmental awareness in the construction industry, aimed at erecting buildings constructed with "healthy" materials, which guarantee **healthy spaces** for everyday life.

Every product bearing the Declare label declares that it does not contain "ingredients" which fall into the Red List, in other words the list of the most harmful pollutants in the construction industry.

This list, which the ILFI draws up and updates directly, points out the substances which pollute the environment, and which can damage the health of those who make them, as well as of the end users following prolonged exposure.

It is a database of products that is continuously updated, which helps end users, and above all designers and manufacturers, **identify the best construction materials for the environment** and for people.

<https://declare.living-future.org/>

L'étiquette pour la transparence des matériaux de construction

Toujours attentive aux questions de durabilité, Supergres a décidé d'adopter l'étiquette **Declare** qui communique aux concepteurs, aux consommateurs finals et aux entreprises d'où vient le produit, sa composition et la manière dont il peut être éliminé à la fin de son cycle de vie.

Née avec cet objectif de **transparence**, l'étiquette Declare est gérée par l'International Living Future Institute, ILFI, une organisation à but non lucratif engagée dans la diffusion d'une sensibilité écologique dans le secteur du bâtiment, destinée à la construction de bâtiments réalisés en utilisant des matériaux « sains », qui garantissent la **salubrité des espaces** dans lesquels on vit au quotidien.

Chaque produit portant l'étiquette Declare déclare ne pas contenir « d'ingrédients » présents dans la Red List, à savoir la liste des matériaux polluants les plus dangereux dans l'industrie du bâtiment.

Cette liste, rédigée et mise à jour directement par l'ILFI, indique les substances qui polluent l'environnement et qui constituent un risque pour la santé des personnes qui les produisent et des utilisateurs finaux à la suite d'une exposition prolongée.

Une base de données de produits actualisée en permanence qui aide les utilisateurs finaux mais surtout les concepteurs et les constructeurs à **identifier les matériaux de construction les meilleurs pour l'environnement** et les personnes.

<https://declare.living-future.org/>

Das Etikett für mehr Transparenz bei Baumaterialien

Supergres hat schon immer auf Nachhaltigkeitsaspekte geachtet und man sich jetzt zur Verwendung des **Declare**-Etiketts entschieden, das Planern, Endverbrauchern und Unternehmen mitteilt, woher das Produkt kommt, woraus es besteht und wie es am Ende seines Lebenszyklus entsorgt werden kann.

Das aus dem Wunsch für mehr **Transparenz** entstandene Declare-Etikett wird vom International Living Future Institute (ILFI) gehandhabt, einer gemeinnützigen Organisation, die sich für die Verbreitung eines ökologischen Bewusstseins im Bausektor einsetzt, mit dem Ziel, dass Gebäude aus „gesunden“ Materialien errichtet werden, die die Gesundheit der Räume gewährleisten, in denen man Tag für Tag lebt.

Jedes Produkt, das das Declare-Etikett trägt, erklärt, dass es keine Bestandteile enthält, die auf der Roten Liste stehen, d.h. auf der Liste mit den schädlichsten umweltbelastenden Werkstoffen in der Bauindustrie.

In dieser Liste, die direkt vom ILFI erstellt und auf den neusten Stand gebracht wird, sind die Stoffe aufgeführt, die die Umwelt verschmutzen und bei längerer Exposition ein Gesundheitsrisiko für Hersteller und Endanwender darstellen.

Eine ständig auf den neusten Stand gebrachte Produktdatenbank, die Endanwendern, aber vor allem Planern und Bauleitern bzw. Bauherren hilft, **die Baustoffe auszumachen, die für die Umwelt** und den Menschen **am besten sind**.

<https://declare.living-future.org/>



ISO 9001

Azienda certificata per la progettazione, produzione e vendita di piastrelle ceramiche in gres porcellanato e monoporosa pasta bianca secondo la norma **ISO 9001**.

The company is certified for the planning, manufacturing and sale of porcelain and white-body ceramic tiles in compliance with the **ISO 9001** norm.

Entreprise certifiée pour la conception, production et vente de carreaux de céramique en grès cérame et pâte blanche selon la norme **ISO 9001**.

Zertifiziertes Unternehmen für die Entwicklung, Produktion und Vertrieb von keramischen Fliesen aus Feinsteinzeug und weißer Masse hergestellt in Übereinstimmung mit der Norm **ISO 9001**.



La norma ISO 17889-1:2021 "Sustainability for ceramic tiles and installation materials" definisce uno standard unico e internazionale per valutare l'impatto ambientale, economico e sociale delle piastrelle ceramiche. Il sistema di valutazione si basa su 38 indicatori, suddivisi tra obbligatori e volontari, e su un sistema di punteggio multi rating.

- **15 requisiti obbligatori** stabiliscono i pre-requisiti minimi che una piastrella deve possedere per essere definita sostenibile. Se un prodotto non soddisfa tutti questi criteri non può concorrere al conseguimento della certificazione.
- **23 requisiti volontari** assegnano un punteggio da 100 ad un massimo di 130, secondo diversi livelli di performance di prodotto e di processo.

Una piastrella è conforme alla norma ISO 17889-1 solo se rispetta tutti i requisiti obbligatori e se raggiunge almeno 117,5 punti nei requisiti volontari.

I 38 requisiti riguardano i seguenti aspetti:

- Sostenibilità ambientale del prodotto
- Sostenibilità ambientale del processo
- Responsabilità sociale della impresa
- Sicurezza del processo di produzione
- Sostenibilità ambientale della catena di fornitura
- Efficienza energetica del processo di produzione

Tutte le collezioni di ceramiche Supergres hanno ottenuto la certificazione ISO 17889.

ISO 17889-1:2021 - Sustainability for ceramic tiles and installation materials - defines a unique, international standard for assessing the environmental, economic and social impact of ceramic tiles. The evaluation system is based on 38 indicators, divided into mandatory and voluntary, and a multi-rating scoring system.

- **15 mandatory requirements** establish the minimum pre-requisites that a tile must have to be defined as sustainable. If a product does not fulfil all these criteria, it cannot compete for certification.
- **23 voluntary requirements** assign a score from 100 to a maximum of 130, according to different levels of product and process performance.

A tile only complies with ISO 17889-1 if it meets all the mandatory requirements and if it achieves at least 117.5 scores in the voluntary requirements.

The 38 requirements cover the following aspects:

- Product environmental sustainability
- Process environmental sustainability
- Corporate social responsibility
- Safety of the production process
- Environmental sustainability of the supply chain
- Energy efficiency of the production process

All Ceramiche Supergres collections have been awarded ISO 17889 certification.

La norme ISO 17889-1:2021 « Sustainability for ceramic tiles and installation materials » est une norme unique et internationale qui évalue l'impact environnemental, économique et social du carrelage en céramique. Le système d'évaluation repose sur 38 indicateurs, dont certains sont obligatoires et d'autres volontaires, ainsi qu'un système de score qui permet d'établir un classement.

- **15 exigences obligatoires** définissent les exigences préliminaires minimum qu'un carreau doit présenter pour être défini durable. Si un produit ne répond pas à tous ces critères, il ne peut pas postuler à l'obtention de la certification.
- **23 exigences volontaires** attribuent un score de 100 à 130 points, selon les différents niveaux de performances du produit et du processus.

Un carreau est conforme à la norme ISO 17889-1 uniquement s'il reflète toutes les exigences obligatoires et atteint au moins 117,5 scores avec les exigences volontaires.

Les 38 exigences portent sur les aspects suivants :

- Durabilité environnementale du produit
- Durabilité environnementale du processus
- Responsabilité sociale de l'entreprise
- Sécurité du processus de production
- Durabilité environnementale de la chaîne d'approvisionnement
- Efficacité énergétique du processus de production

Toutes les collections de Ceramiche Supergres ont obtenu la certification ISO 17889.

ISO 17889-1:2021 „Sustainability for ceramic tiles and installation materials“ definiert eine einzigartige, internationale Norm zur Bewertung der ökologischen, wirtschaftlichen und sozialen Auswirkungen von keramischen Fliesen. Das Bewertungssystem basiert auf 38 Indikatoren, die in obligatorische und freiwillige unterteilt sind, sowie auf einem mehrstufigen Punktesystem.

- **15 verbindliche** Anforderungen legen die Mindestvoraussetzungen fest, die eine Fliese erfüllen muss, um als nachhaltig zu gelten. Erfüllt ein Produkt nicht alle diese Kriterien, kann es nicht zertifiziert werden.
- **23 freiwillige Anforderungen** vergeben eine Punktzahl von 100 bis maximal 130, je nach den verschiedenen Stufen der Produkt- und Prozessleistung.

Eine Fliese entspricht nur dann der Norm ISO 17889-1, wenn sie alle verbindlichen Anforderungen erfüllt und bei den freiwilligen Anforderungen mindestens 117,5 Punkte erreicht.

Die 38 Anforderungen umfassen die folgenden Aspekte:

- Ökologische Nachhaltigkeit der Produkte
- Umweltverträglichkeit des Prozesses
- Soziale Verantwortung des Unternehmens
- Sicherheit des Produktionsprozesses
- Ökologische Nachhaltigkeit in der Lieferkette
- Energieeffizienz des Produktionsprozesses

Alle Kollektionen von Ceramiche Supergres sind nach ISO 17889 zertifiziert.

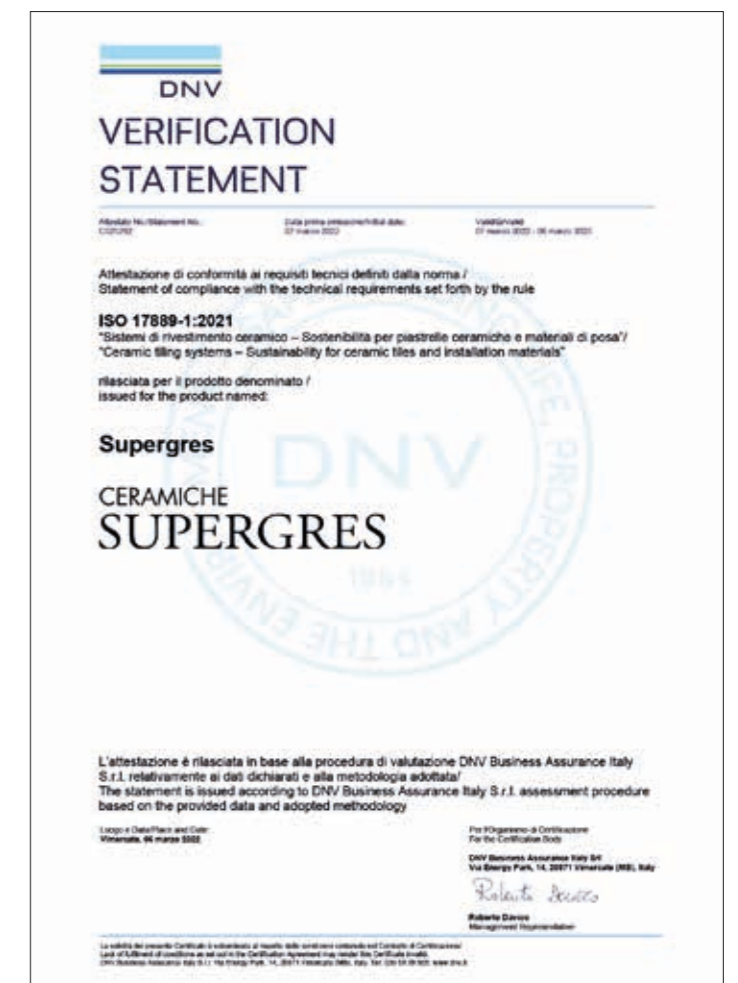

UNI ISO 45001 - SALUTE E SICUREZZA SUL LAVORO

La sicurezza del personale è di fondamentale importanza per Supergres, che cerca il miglioramento continuo attraverso costanti controlli, investimenti e formazione. Supergres ha ottenuto la certificazione ISO 45001, il nuovo modello internazionale che descrive gli elementi del sistema di gestione della salute e sicurezza sul lavoro, il cui obiettivo è quello di migliorare le prestazioni in materia di sicurezza e fornire un luogo di lavoro sano e sicuro.

UNI ISO 45001 - OCCUPATIONAL HEALTH AND SAFETY

Employees' safety is of paramount importance to Supergres, which seeks continuous improvement through constant monitoring, investment and training. Supergres has been awarded ISO 45001 certification, the new international model describing the elements of the occupational health and safety management system, which aims to improve safety performance and provide a healthy and safe workplace.

UNI ISO 45001 - SANTÉ ET SÉCURITÉ AU TRAVAIL

La sécurité du personnel est d'une importance capitale pour Supergres, qui cherche constamment à s'améliorer à travers des contrôles constants, des investissements et des formations. Supergres a obtenu la certification ISO 45001, le nouveau modèle international qui décrit les éléments du système de gestion de la santé et de la sécurité au travail, dont l'objectif est d'améliorer les performances en termes de sécurité et de fournir un lieu de travail sain et sûr.

UNI ISO 45001 - GESUNDHEIT UND SICHERHEIT AM ARBEITSPLATZ

Die Sicherheit des Personals ist für Supergres von größter Bedeutung. Durch ständige Überwachung, Investitionen und Schulungen strebt das Unternehmen eine kontinuierliche Verbesserung an. Supergres hat die Zertifizierung nach ISO 45001 erhalten, dem neuen internationalen Modell, das die Elemente eines Managementsystems für Sicherheit und Gesundheitsschutz am Arbeitsplatz beschreibt, das darauf abzielt, die Sicherheitsleistung zu verbessern und einen gesunden und sicheren Arbeitsplatz zu schaffen.



MARCHIO EUROPEO DI SICUREZZA – La marcatura CE è la certificazione di sicurezza del prodotto richiesta dall'Unione Europea ed ha lo scopo di salvaguardare la salute delle persone e i beni nelle opere di costruzione. Il regolamento europeo per i materiali da costruzione 305/2011, ha introdotto la dichiarazione di prestazione (DOP – declaration of performance), marchio con il quale il fabbricante comunica i requisiti di sicurezza dei propri materiali. Le dichiarazioni di prestazione di Ceramiche Supergres sono disponibili sul nostro sito www.supergres.com.

EUROPEAN SAFETY MARK – The CE mark is the safety certification of products required by the European Union and is aimed at the safeguard of the health of people at the workplace. The European regulation for building materials 305/2011 introduced the DOP – declaration of performance, with which the manufacturer informs about the safety requirements of materials. Ceramiche Supergres declarations of performance are available on the website www.supergres.com.

MARQUAGE EUROPÉEN DE SÉCURITÉ – Le marquage CE est la certification de sécurité du produit requis par l'Union Européenne et a pour but de sauvegarder la santé des personnes et des biens dans les travaux de construction. Le règlement européen pour les matériaux de construction 305/2011 a introduit la déclaration des performances (DOP – declaration of performance), marquage à travers lequel le fabricant communique les critères de sécurité de ses propres matériaux. Les déclarations de performances de Ceramiche Supergres sont disponibles sur notre site www.supergres.com.

EUROPÄISCHE SICHERHEITSMARKE - Die CE-Kennzeichnung ist die Sicherheitszertifizierung eines Produktes, das von der Europäischen Union gefordert wird und soll die Gesundheit von Menschen und Gütern im Bereich Bau schützen. Die Europäische Bauprodukte-Verordnung 305/2011 hat die Leistungserklärung (DoP - declaration of performance) eingeführt, ein Dokument, mit dem der Hersteller die Sicherheitsanforderungen der eigenen Bauprodukte mitteilt. Die Leistungserklärungen von Ceramiche Supergres sind auch auf der Internetseite www.supergres.com verfügbar.

CERTIFICAZIONE WELL WELL CERTIFICATION

CERAMICHE
SUPERGRES

La certificazione LEED certifica con un rating l'edificio per la sua sostenibilità, il sistema di valutazione WELL lo certifica per la sua salubrità. Con l'introduzione della **certificazione WELL (Well Building Standard)** l'interesse si sposta sugli utenti. È infatti il benessere delle persone che trascurano il loro tempo all'interno dell'edificio, che diventa oggetto di valutazione. L'obiettivo della certificazione è quella di valutare le caratteristiche dell'immobile che soddisfano il benessere delle persone, senza tralasciare l'utilizzo di risorse rinnovabili, la sostenibilità ambientale e la tutela del paesaggio. Per valutare il soddisfacimento e il benessere dell'utenza sono stati definiti i seguenti concept (<https://www.wellcertified.com>):

ARIA – valutazione della qualità dell'aria all'interno dell'edificio; promuovere l'utilizzo di materiali di costruzione atossici che non rilasciano alcun tipo di sostanza, e favorire l'utilizzo di sistemi che garantiscano un corretto ricambio d'aria.
ACQUA – accesso facilitato per tutti gli utenti ad acqua pulita, pura e priva di materiali inquinanti.
LUCE – massimizzare la luce naturale, limitando quella artificiale; in fase progettuale è fondamentale la scelta dell'orientamento dell'edificio.
COMFORT TERMICO – favorisce il mantenimento della temperatura ottimale, monitorando i livelli di umidità dell'ambiente.
SUONO – stimola la riduzione di rumori, favorendo il raggiungimento del massimo comfort acustico, utilizzando sistemi e materiali fonoassorbenti.
MATERIALI – premia l'utilizzo di materiali sostenibili e riciclabili, con basse emissioni, di facile manutenzione, igienici e a basso impatto ambientale
MOVIMENTO – valuta il posizionamento degli ambienti rispetto alle aree che consentono il movimento (per esempio le scale), per incentivare il movimento e ridurre la sedentarietà.
ALIMENTAZIONE – incentiva il mangiare sano, con un accurata selezione delle materie prime nelle mense aziendali, scolastiche, ospedaliere, col fine di aumentare la consapevolezza alimentare;
MENTE – interessa la salute fisica e mentale dell'essere umano, che è favorita da ambienti salubri e puliti, e ottimizza il benessere di vivere, lavorare e "sentirsi bene" al loro interno;
COMUNITA' – promuove la massima accessibilità dell'edificio e sostiene la vita degli occupanti attraverso incentivi e sostegni per le famiglie
INNOVAZIONE – incoraggiare l'innovazione, con la presentazione di nuove idee per nuove caratteristiche all'interno delle categorie del sistema di valutazione Well.

Tutti i prodotti della gamma Supergres concorrono all'ottenimento di punteggi, principalmente in relazione ai concept Aria, Materiali, Comfort termico e Innovazione, per le seguenti caratteristiche:
- Cessione nulla di VOC
- Non proliferazione di microbi e muffe
- Conformità per l'utilizzo nel riscaldamento a pavimento
- Assenza di amianto
- Assenza di Mercurio, Cadmio, Antimonio, Cromo
- Assenza di sostanze REACH
- Disponibilità di una etichetta DECLARE

La certificazione WELL è gestita dall'International WELL® Building Institute (IWBI) ed è rilasciata dal Green Business Certification Inc., ovvero dal medesimo istituto che rilascia la certificazione LEED. I livelli di certificazione WELL sono silver, gold, platinum. Il sistema di rating WELL è strutturato per integrarsi perfettamente ai protocolli di sostenibilità ambientale, in particolare con la certificazione LEED con la quale condivide, oltre che il medesimo ente di certificazione, anche la struttura in requisiti, crediti e punteggi.

WELL CERTIFICATION

LEED certification certifies the building for its sustainability, the WELL rating system certifies it for its healthiness. With the introduction of the **WELL (Well Building Standard) certification**, the focus shifts to the users. It is in fact the well-being of the people who spend their time inside the building that becomes the subject matter of evaluation. The aim of the certification is to assess the characteristics of the building that satisfy people's well-being, without neglecting the use of renewable resources, environmental sustainability and landscape protection. The following concepts were defined to assess user satisfaction and well-being (<https://www.wellcertified.com>):

AIR - monitoring the quality of air inside the building; promoting the use of non-toxic building materials that do not release any kind of substance, and encouraging the use of systems that ensure proper air exchange.
WATER - provide access to clean drinking water, pure and free of polluting materials.
LIGHT - maximise natural light, limiting artificial light; the choice of building orientation is crucial in the design phase.
THERMAL COMFORT - helps maintain an optimal temperature by monitoring humidity levels in the room.
SOUND - stimulates noise reduction, helping to achieve maximum acoustic comfort by using sound reducing systems and materials.
MATERIALS - rewards the use of sustainable and recyclable materials, with low emissions, easy maintenance, hygienic and low environmental impact
MOVEMENT - assesses the positioning of rooms in relation to areas that allow movement (e.g. stairs), to promote physical activity and reduce inactivity.
NOURISHMENT - fosters healthy eating, with a careful selection of raw materials in company, school and hospital canteens, in order to increase food diet awareness;
MIND - affects the physical and mental health of human beings, which is promoted by healthy and clean environments, and optimises the well-being of living, working and 'feeling good' in them;
COMMUNITY - promotes maximum accessibility of the building and supports the lives of the occupants through incentives and family support
INNOVATION - encouraging innovation, with the submission of new ideas for new features within the categories of the WELL evaluation system.

All products in the Supergres range compete for points, mainly in relation to the Air, Materials, Thermal Comfort and Innovation concepts, for the following characteristics:
- Zero VOC release
- Non-proliferation of microbes and moulds
- Compliance for use in underfloor heating
- Asbestos free
- Free of mercury, cadmium, antimony, chromium
- Free of REACH substances
- Availability of a DECLARE label

WELL certification is managed by the International WELL® Building Institute (IWBI) and is issued by Green Business Certification Inc., that is the same institute that issues LEED certification. WELL certification levels are silver, gold and platinum. WELL rating system is structured to integrate with environmental sustainability protocols, in particular with LEED certification with which it shares not only the same certification body but also the structure of prerequisites, credits and scores.

CERTIFICATION WELL

La certification LEED certifie le bâtiment selon un classement en matière de durabilité, le système d'évaluation WELL le certifie du point de vue de la salubrité. Avec l'introduction de la **certification WELL (Well Building Standard)**, l'intérêt se tourne vers les utilisateurs. C'est en effet le bien-être des personnes qui passent leur temps dans le bâtiment qui fait l'objet de l'évaluation. Cette certification a pour objectif d'évaluer les caractéristiques du bâtiment qui satisfont au bien-être des personnes, sans négliger l'utilisation de ressources renouvelables, le respect de l'environnement et la protection du paysage. Les notions suivantes ont été définies afin d'évaluer la satisfaction et le bien-être des utilisateurs (<https://www.wellcertified.com>) :

AIR - évaluation de la qualité de l'air au sein du bâtiment ; promouvoir l'utilisation de matériel de construction atoxique, qui ne dégage aucun type de substance, et favoriser l'utilisation de systèmes qui garantissent une bonne aération.
EAU - accès facilité à de l'eau propre, pure et dépourvue de matière polluante pour tous les utilisateurs.
LUMIÈRE - en phase de conception, maximiser la lumière naturelle, en limitant la lumière artificielle, est fondamental pour le choix de l'orientation du bâtiment.
CONFORT THERMIQUE - il favorise le maintien d'une température optimale, en surveillant le niveau d'humidité de l'environnement.
SON - stimule la réduction du bruit, en favorisant l'atteinte du plus grand confort acoustique grâce à l'utilisation de systèmes et matériel phono-absorbant.
MATÉRIEL - récompense l'utilisation de matériel respectueux de l'environnement et recyclable, à faibles émissions, facile à entretenir, hygiénique et à faible impact sur l'environnement.
MOUVEMENT - évalue l'emplacement des espaces par rapport aux zones qui stimulent le mouvement (par exemple les escaliers), afin de stimuler le mouvement et de réduire la sédentarité.
ALIMENTATION - stimule à manger de manière saine, en sélectionnant soigneusement les matières premières dans les cantines des entreprises, écoles et hôpitaux, afin d'augmenter la conscience alimentaire ;
ESPRIT - du point de vue de la santé physique et mentale de l'être humain, l'esprit est favorisé dans les environnements salubres et propres, il optimise le bien-être de la vie, du travail et le fait de « se sentir bien » à l'intérieur ;
COMMUNAUTÉ - favorise l'accès optimal au bâtiment et contribue à la vie des occupants par le biais de récompenses et soutiens aux familles
INNOVATION - encourage l'innovation, à travers la présentation de nouvelles idées pour les nouvelles caractéristiques au sein des catégories du système d'évaluation Well.

Tous les produits de la gamme Supergres concourent à l'obtention de points, principalement en rapport aux notions de l'air, du matériel, du confort thermique et de l'innovation, pour les caractéristiques suivantes :
- Dégagement de COV nul
- Absence de prolifération de microbes et moisissures
- Conformité pour l'utilisation du plancher chauffant
- Absence d'amiante
- Absence de mercure, cadmium, antimoine et chrome
- Absence de substances REACH
- Disponibilité d'une étiquette DECLARE

La certification WELL est gérée par l'International WELL® Building Institute (IWBI) et elle est délivrée par le Green Business Certification Inc., l'institut qui délivre également la certification LEED. Les niveaux de certification WELL sont silver, gold et platinum. Le système d'évaluation WELL est structuré de façon à s'intégrer parfaitement dans les protocoles de respect de l'environnement, notamment à travers la certification LEED avec laquelle il partage le même organisme de certification, mais aussi la structure des exigences nécessaires, des crédits et des points.

WELL ZERTIFIZIERUNG

Die LEED-Zertifizierung bescheinigt dem Gebäude seine Nachhaltigkeit, das WELL-Bewertungssystem seine Gesundheit. Mit der Einführung der **WELL-Zertifizierung (Well Building Standard)** rücken die Nutzer in den Mittelpunkt. Das Wohlbefinden der Menschen, die sich im Gebäude aufhalten, wird zum Gegenstand der Bewertung. Ziel der Zertifizierung ist es, die Eigenschaften des Gebäudes zu bewerten, die dem Wohlbefinden der Menschen dienen, ohne die Nutzung erneuerbarer Ressourcen, die ökologische Nachhaltigkeit und den Landschaftsschutz zu vernachlässigen. Die folgenden Konzepte wurden definiert, um die Zufriedenheit und das Wohlbefinden der Nutzer zu bewerten (<https://www.wellcertified.com>):

LUFT - Bewertung der Luftqualität im Gebäude; Förderung der Verwendung von ungiftigen Baumaterialien, die keine Stoffe freisetzen, und Förderung der Verwendung von Systemen, die einen angemessenen Luftaustausch gewährleisten.
WASSER - Einfacher Zugang für alle Nutzer zu sauberem, reinem Wasser, das frei von umweltschädlichen Stoffen ist.
LICHT - Maximierung des natürlichen Lichts, Begrenzung des künstlichen Lichts; die Wahl der Gebäudeausrichtung ist in der Entwurfsphase entscheidend.
WÄRMEKOMFORT - Unterstützt die Aufrechterhaltung einer optimalen Temperatur durch Überwachung der Luftfeuchtigkeit im Raum.
AKUSTIK - Fördert die Lärminderung und trägt durch den Einsatz schallabsorbierender Systeme und Materialien zu maximalem akustischen Komfort bei.
MATERIALIEN - Belohnt die Verwendung nachhaltiger und recycelbarer Materialien, die emissionsarm, wartungsfreundlich, hygienisch und umweltfreundlich sind.
BEWEGUNG - Bewertet die Positionierung von Räumen in Bezug auf Bereiche, die Bewegung ermöglichen (z.B. Treppen), um Bewegung zu fördern und Sesshaftigkeit zu reduzieren.
ERNÄHRUNG - Fördert eine gesunde Ernährung durch eine sorgfältige Auswahl der Rohstoffe in Betriebs-, Schul- und Krankenhauskantinen, um das Bewusstsein für Lebensmittel zu schärfen.
GEIST - Betrifft die körperliche und geistige Gesundheit des Menschen, die durch eine gesunde und saubere Umwelt gefördert wird, und optimiert Wellness beim Leben, Arbeiten und „Wohlfühlen“.
COMMUNITY - Fördert die maximale Zugänglichkeit des Gebäudes und unterstützt das Leben der Bewohner durch Anreize und Familienunterstützung
INNOVATION - Förderung der Innovation durch neue Ideen für neue Funktionen innerhalb der Kategorien des Well-Bewertungssystems.

Alle Produkte der Supergres-Palette streben nach Punkten in Bezug auf die Konzepte Luft, Materialien, Wärmekomfort und Innovation; es handelt sich hauptsächlich um folgende Eigenschaften:
- Keine VOC-Freisetzung
- Keine Ausbreitung von Mikroben und Schimmelpilzen
- Konformität für die Verwendung in Fußbodenheizungen
- Kein Asbest-Gehalt
- Frei von Quecksilber, Cadmium, Antimon und Chrom
- Keine REACH-Stoffe
- DECLARE-Label vorhanden

Die WELL®-Zertifizierung wird vom International WELL® Building Institute (IWBI) verwaltet und von Green Business Certification Inc. vergeben, demselben Institut, das auch die LEED-Zertifizierung vergibt. Die WELL-Zertifizierungsstufen sind Silber, Gold und Platin. Das WELL-Rating-System ist so strukturiert, dass sie sich in die Protokolle zur ökologischen Nachhaltigkeit einfügt, insbesondere in die LEED-Zertifizierung, mit der sie nicht nur die gleiche Zertifizierungsstelle, sondern auch die Struktur der Voraussetzungen, Credits und Punkte teilt.

CARATTERISTICHE TECNICHE TECHNICAL CHARACTERISTICS

Caractéristiques techniques / Technische eigenschaften

RIVESTIMENTO IN PASTA BIANCA - WHITE BODY WALL TILES REVÊTEMENTS EN PÂTE BLANCHE - WEIßSCHERBIGER WANDFLIESEN

Norma di riferimento: EN 14411 (ISO 13006) Allegato L Piastrelle di ceramica pressate a secco (Ev > 10 %)

Reference standard: EN 14411 (ISO 13006) Appendix L Dry pressed ceramic tiles (Ev > 10 %)

Norme retenue: EN 14411 (ISO 13006) Annexe L Carreaux céramiques pressés à sec (Ev > 10 %)

Besugznorm: EN 14411 (ISO 13006) Anlage L Trockengepresste keramische Fliesen und Platten (Ev > 10 %)

Gruppo B III GL

Caratteristiche tecniche Technical characteristics Caractéristiques techniques Technische eigenschaften	Norma Norms Normes Normen	Requisiti richiesti Requirements Conditions requisés Geforderte eigenschaften			* Valore medio Supergres Average rating Valeur moyenne Durchschnittswert	
		7 cm ≤ N < 15 cm	N ≥ 15 cm			
<p>Lunghezza e larghezza Length and width Longuer et largeur Länge und Breite</p>	ISO 10545-2	RETTIFICATI	± 0,4 mm	± 0,3 %	± 1,0 mm	Conforme According to Conforme Gemäss
			± 0,4 mm	± 0,3 %	± 0,8 mm	Conforme According to Conforme Gemäss
			± 0,4 mm	± 0,3 %	± 1,5 mm	Conforme According to Conforme Gemäss
			± 0,6 mm	± 0,4 %	± 1,8 mm	Conforme According to Conforme Gemäss
<p>Rettilineità degli spigoli Straightness of sides Equerrage des angles Kantengeradheit</p>	ISO 10545-2	NON RETTIFICATI	± 0,9 mm	± 0,6 %	± 2,0 mm	Conforme According to Conforme Gemäss
			± 0,8 mm	± 0,5 %	± 1,5 mm	Conforme According to Conforme Gemäss
			± 0,8 mm	± 0,5 %	± 2,0 mm	Conforme According to Conforme Gemäss
			± 0,8 mm	± 0,5 %	± 2,0 mm	Conforme According to Conforme Gemäss
<p>Ortogonalità ** Rectangularity Orthogonalité Rechtwinkligkeit</p>	ISO 10545-2	NON RETTIFICATI				
<p>Planarità Flatness Planéité Planität</p>	ISO 10545-2	NON RETTIFICATI				

Caratteristiche tecniche Technical characteristics Caractéristiques techniques Technische eigenschaften	Norma Norms Normes Normen	Requisiti richiesti Requirements Conditions requisés Geforderte eigenschaften			* Valore medio Supergres Average rating Valeur moyenne Durchschnittswert
		7 cm ≤ N < 15 cm	N ≥ 15 cm		
<p>Spessore Thickness Épaisseur Stärke</p>	ISO 10545-2	± 0,5 mm	± 10 %	± 0,5 mm	Conforme According to Conforme Gemäss
<p>Assorbimento % d'acqua Water absorption Absorption d'eau Wasseraufnahme</p>	ISO 10545-3	Ev > 10%			Conforme According to Conforme Gemäss
<p>Determinazione della resistenza a flessione e della forza di rottura Flexion and break resistance Résistance à la flexion et à la force de ropture Biegefestigkeit und Bruchlast</p>	ISO 10545-4	Spessore ≥ 7,5 mm	$\left[\begin{array}{l} S \geq 600 \text{ N} \\ R \geq 15 \text{ N/mm}^2 \end{array} \right.$		Conforme According to Conforme Gemäss
<p>Determinazione della resistenza al cavillo Crazing resistance Résistance aux craquelures Haarriß-Beständigkeit</p>	ISO 10545-11	Richiesta Required Requise Enforderlich			Conforme According to Conforme Gemäss
<p>Determinazione della resistenza chimica (GL) Chemical resistance (GL) Résistance chimique (GL) Chemikalienbeständigkeit (GL)</p>	ISO 10545-13	Classe GB minimo Class GB min Categorie GB min Klasse GB min			Conforme According to Conforme Gemäss
<p>Determinazione della resistenza alle macchie Resistance to staining Résistance aux taches Beständigkeit gegen Fleckenbil</p>	ISO 10545-14	Classe 3 minimo Class 3 min Categorie 3 min Klasse 3 minc			Conforme According to Conforme Gemäss
<p>Reazione al fuoco Reaction to fire Réaction au feu Brandverhalten</p>	-	Classe A1 o A1 fl Class A1 o A1 fl Class A1 ou A1 fl Klasse A1 oder A1 fl			Conforme According to Conforme Gemäss

* Valori riferiti ai fondi. Le caratteristiche tecniche fanno riferimento al formato nominale delle piastrelle espresso in mm.
These values refer to the bottoms. The technical characteristics refer to the nominal size of tiles expressed in mm.
Valeurs se référant aux fonds. Les caractéristiques techniques se réfèrent au format nominal des carreaux exprimé en mm.
Werte bezogen auf Grundriesen. Die Angaben beziehen sich auf die Nenngröße der Fliesen in mm.

Se non indicato diversamente, i valori delle prove tecniche si riferiscono alla superficie naturale.
Unless otherwise indicated, the values of technical tests refer to the natural surface finish.
Sauf indication contraire, les valeurs des tests techniques se rapportent à la surface naturelle.
Wenn nicht anders angegeben beziehen sich die Werte der technischen Tests auf die natürliche Oberfläche.

** Per piastrelle rettangolari che abbiano il lato maggiore L ≥ 60 cm, e rapporto tra i lati ≥ 3, la misurazione dell'ortogonalità deve venire condotta solo sul lato corto.
For rectangular tiles with longest side L ≥ 60 cm and a ratio length/width L/W ≥ 3, the measurement of orthogonality should only be carried out on short edges.
Pour les carreaux rectangulaires qui ont le côté le plus long L ≥ 60 cm, et le rapport entre les côtés ≥ 3, la mesure de l'orthogonalité se fait seulement sur le côté le plus court.
Bei rechteckigen Fliesen, mit der längsten Seite L ≥ 60 cm und einem Seitenverhältnis von ≥ 3 darf die Messung der Rechteckigkeit nur an der kurzen Seite durchgeführt werden.

GRES PORCELLANATO - PORCELAIN TILE - GRÈS CÉRAME - FEINSTEINZEUG









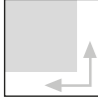

Norma di riferimento: EN 14411 (ISO 13006) Allegato G Piastrelle di ceramica pressate a secco con basso assorbimento d'acqua ($E_v \leq 0,5 \%$)

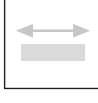

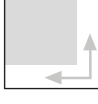

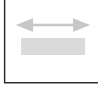
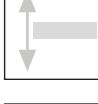





Reference standard: EN 14411 (ISO 13006) Appendix G Dry pressed ceramic tiles with low water absorption ($E_v \leq 0,5 \%$)

Norme retenue: EN 14411 (ISO 13006) Annexe G Carreaux céramiques pressés à sec avec faible absorption d'eau ($E_v \leq 0,5 \%$)

Besugznorm: EN 14411 (ISO 13006) Anlage G Trockengepresste keramische Fliesen und Platten mit niedriger Wasseraufnahme ($E_v \leq 0,5 \%$)

Gruppo B la

Caratteristiche tecniche Technical characteristics Caracteristiques techniques Technische eigenschaften	Norma Norms Normes Normen	Requisiti richiesti Requirements Conditions requisés Geforderte eigenschaften	* Valore medio Supergres Average rating Valeur moyenne Durchschnittswert																
 Lunghezza e larghezza Length and width Longuer et largeur Länge und Breite  Rettilinearità degli spigoli Straightness of sides Equerrage des angles Kantengeradheit  Ortogonalità ** Rectangularity Orthogonalité Rechtwinkligkeit  Planarità Flatness Planéité Planität	ISO 10545-2	RETTIFICATI	<table border="1"> <thead> <tr> <th>7 cm ≤ N < 15 cm</th> <th colspan="2">N ≥ 15 cm</th> </tr> </thead> <tbody> <tr> <td>± 0,4 mm</td> <td>± 0,3 %</td> <td>± 1,0 mm</td> </tr> <tr> <td>± 0,4 mm</td> <td>± 0,3 %</td> <td>± 0,8 mm</td> </tr> <tr> <td>± 0,4 mm</td> <td>± 0,3 %</td> <td>± 1,5 mm</td> </tr> <tr> <td>± 0,6 mm</td> <td>± 0,4 %</td> <td>± 1,8 mm</td> </tr> </tbody> </table>	7 cm ≤ N < 15 cm	N ≥ 15 cm		± 0,4 mm	± 0,3 %	± 1,0 mm	± 0,4 mm	± 0,3 %	± 0,8 mm	± 0,4 mm	± 0,3 %	± 1,5 mm	± 0,6 mm	± 0,4 %	± 1,8 mm	<p>Conforme According to Conforme Gemäss</p> <p>Conforme According to Conforme Gemäss</p> <p>Conforme According to Conforme Gemäss</p> <p>Conforme According to Conforme Gemäss</p>
		7 cm ≤ N < 15 cm	N ≥ 15 cm																
		± 0,4 mm	± 0,3 %	± 1,0 mm															
		± 0,4 mm	± 0,3 %	± 0,8 mm															
± 0,4 mm	± 0,3 %	± 1,5 mm																	
± 0,6 mm	± 0,4 %	± 1,8 mm																	
 Lunghezza e larghezza Length and width Longuer et largeur Länge und Breite  Rettilinearità degli spigoli Straightness of sides Equerrage des angles Kantengeradheit  Ortogonalità ** Rectangularity Orthogonalité Rechtwinkligkeit  Planarità Flatness Planéité Planität	ISO 10545-2	NON RETTIFICATI	<table border="1"> <tbody> <tr> <td>± 0,9 mm</td> <td>± 0,6 %</td> <td>± 2,0 mm</td> </tr> <tr> <td>± 0,8 mm</td> <td>± 0,5 %</td> <td>± 1,5 mm</td> </tr> <tr> <td>± 0,8 mm</td> <td>± 0,5 %</td> <td>± 2,0 mm</td> </tr> <tr> <td>± 0,8 mm</td> <td>± 0,5 %</td> <td>± 2,0 mm</td> </tr> </tbody> </table>	± 0,9 mm	± 0,6 %	± 2,0 mm	± 0,8 mm	± 0,5 %	± 1,5 mm	± 0,8 mm	± 0,5 %	± 2,0 mm	± 0,8 mm	± 0,5 %	± 2,0 mm	<p>Conforme According to Conforme Gemäss</p> <p>Conforme According to Conforme Gemäss</p> <p>Conforme According to Conforme Gemäss</p> <p>Conforme According to Conforme Gemäss</p>			
		± 0,9 mm	± 0,6 %	± 2,0 mm															
		± 0,8 mm	± 0,5 %	± 1,5 mm															
		± 0,8 mm	± 0,5 %	± 2,0 mm															
± 0,8 mm	± 0,5 %	± 2,0 mm																	
 Spessore Thickness Epaisseur Stärke	ISO 10545-2	± 0,5 mm	± 5 %	± 0,5 mm	Conforme According to Conforme Gemäss														
 Assorbimento % d'acqua Water absorption Absorption d'eau Wasseraufnahme	ISO 10545-3	$E_v \leq 0,5\%$		Conforme According to Conforme Gemäss															
 Determinazione della resistenza a flessione e della forza di rottura Flexion and break resistance Résistance à la flexion et à la force de rupture Biegefestigkeit und Bruchlast	ISO 10545-4	Spessore ≥ 7,5 mm	$S \geq 1300$ $R \geq 35 \text{ N/mm}^2$		Conforme According to Conforme Gemäss														
		Spessore < 7,5 mm	$S \geq 700 \text{ N}$ $R \geq 35 \text{ N/mm}^2$																
 Determinazione della resistenza all'abrasione profonda Abrasion resistance Résistance à l'abrasion profonde Tiefenverschleissbeständigkeit	ISO 10545-6	$\leq 175 \text{ mm}^3$		Conforme According to Conforme Gemäss															

Caratteristiche tecniche Technical characteristics	Norma Norms	Requisiti richiesti Requirements	* Valore medio Supergres Average rating
 Determinazione della resistenza all'abrasione superficiale PEI Résistance à l'abrasion superficielle PEI Beständigkeit gegen Abrieb PEI Surface abrasion resistance PEI	ISO 10545-7	Classificazione PEI Classification PEI Klassifizierung PEI Classification PEI	Risultati delle prove disponibili in azienda. Test details can be obtained from the company. Résultats des tests disponibles auprès de l'entreprise. Die Ergebnisse der Prüfungen sind beim Unternehmen erhältlich.
 Coefficiente di espansione termica lineare tra 20° e 100° C Dilatation thermique linéaire entre 20°C et 100°C Lineare Waerme-ausdehnung zwischen 20°C und 100°C Linear thermal expansion 20°C to 100°C	ISO 10545-8	Metodo di prova disponibile Méthode d'essai disponible Prüfverfahren verfügbar Test method available	Conforme According to Conforme Gemäss
 Resistenza agli sbalzi termici Résistance aux écarts de Température Temperaturwechselbeständigkeit Thermal shock resistance	ISO 10545-9	Metodo di prova disponibile Méthode d'essai disponible Prüfverfahren verfügbar Test method available	Conforme According to Conforme Gemäss
 Resistenza al gelo Résistance au gel Frostbeständigkeit Frost resistance	ISO 10545-12	Metodo di prova disponibile Méthode d'essai disponible Prüfverfahren verfügbar Test method available	Conforme According to Conforme Gemäss
 Determinazione della resistenza chimica Résistance chimique Chemikalienbeständigkeit Chemical resistance	ISO 10545-13	Classe B minimo Classe B min Categorie B min Klasse B min	Conforme According to Conforme Gemäss
 Determinazione della resistenza alle macchie Résistance aux taches Beständigkeit gegen Fleckenbil Resistance to staining	ISO 10545-14	Classe 3 minimo Classe 3 min Categorie 3 min Klasse 3 min	Conforme According to Conforme Gemäss
 Reazione al fuoco Reaction to fire Réaction au feu Brandverhalten	-	Classe A1 o A1 fl Class A1 o A1 fl Class A1 ou A1 fl Klasse A1 oder A1 fl	Conforme According to Conforme Gemäss
 Resistenza allo scivolamento Résistance au glissement Bestimmung der Rutschhemmungsfähigkeit Slip resistance	EN 16165 (previously DIN 51130)	Classificazione R Evaluación R Classification R Klassifizierung R	Vedere dettaglio See chart Voir liste Siehe tab.
 Resistenza allo scivolamento - superfici bagnate calpestio a piedi scalzi Résistance au glissement - surfaces mouillées passage à pieds nus Bestimmung der Rutschhemmungsfähigkeit - nasse Oberfläche - Barfußgehen Coefficient of friction - dry surfaces walking on barefoot	EN 16165 (previously DIN 51097)	Classificazione A B C Evaluación A B C Classification A B C Klassifizierung A B C	Vedere dettaglio See chart Voir liste Siehe tab.
 Resistenza allo scivolamento - coefficiente di attrito dinamico (DCOF) Résistance au glissement - résistance de frottement dynamique Bestimmung der Rutschhemmungsfähigkeit - dynamischer reibungskoeffizient Slip resistance - dynamic friction coefficient	ANSI A326.3	≥ 0,42 wet	Vedere dettaglio See chart Voir liste Siehe tab.
 Coefficiente di attrito dinamico Résistance de frottement dynamique Dynamischer reibungskoeffizient Dynamic friction coefficient	METODO B.C.R.A.	D.M.I. Giugno 1989 n.236 ($\mu > 0,40$)	Vedere dettaglio See chart Voir liste Siehe tab.

* Valori riferiti ai fondi. Le caratteristiche tecniche fanno riferimento al formato nominale delle piastrelle espresso in mm. These values refer to the bottoms. The technical characteristics refer to the nominal size of tiles expressed in mm. Valeurs se référant aux fonds. Les caractéristiques techniques se réfèrent au format nominal des carreaux exprimé en mm. Werte bezogen auf Grundfliesen. Die Angaben beziehen sich auf die Nenngröße der Fliesen in mm.

Se non indicato diversamente, i valori delle prove tecniche si riferiscono alla superficie naturale. Unless otherwise indicated, the values of technical tests refer to the natural surface finish. Sauf indication contraire, les valeurs des tests techniques se rapportent à la surface naturelle. Wenn nicht anders angegeben beziehen sich die Werte der technischen Tests auf die natürliche Oberfläche.

** Per piastrelle rettangolari che abbiano il lato maggiore $L \geq 60 \text{ cm}$, e rapporto tra i lati ≥ 3 , la misurazione dell'ortogonalità deve venire condotta solo sul lato corto. For rectangular tiles with longest side $L \geq 60 \text{ cm}$ and a ratio length/width $L/W \geq 3$, the measurement of orthogonality should only be carried out on short edges. Pour les carreaux rectangulaires qui ont le côté le plus long $L \geq 60 \text{ cm}$, et le rapport entre les côtés ≥ 3 , la mesure de l'orthogonalité se fait seulement sur le côté le plus court. Bei rechteckigen Fliesen, mit der längsten Seite $L \geq 60 \text{ cm}$ und einem Seitenverhältnis von ≥ 3 darf die Messung der Rechteckigkeit nur an der kurzen Seite durchgeführt werden.

Supergres ha ottenuto per alcune collezioni in gres porcellanato la certificazione UPEC, il marchio di qualità francese rilasciato in base ai test previsti dalla normativa europea EN 14411 e dai Cahiers tecnici dell'istituto CSTB. Ad ogni singolo articolo viene assegnata una classificazione UPEC che ne attesta l'idoneità all'installazione nei diversi ambienti di destinazione. Per ottenere ulteriori informazioni consultare il sito www.supergres.com/upec

Supergres has, for some of the collections, obtained the UPEC certification, the French quality mark awarded following tests in compliance with the EN 14411 European standards and with the Technical Cahiers of the CSTB institute. Every single product is awarded an UPEC grade certifying its suitability for different destinations of use. For further details, please visit www.supergres.com/upec

Supergres a obtenu pour certaines collections en grès cérame la certification UPEC, le label de qualité française relâché selon les tests prévus par la norme européenne EN 14411 et les Cahiers techniques de l'institut CSTB. Chaque article est associé à une classification UPEC qui en atteste la conformité à l'installation dans les divers espaces d'utilisation. Pour obtenir plus d'informations sur la certification, veuillez consulter le site www.supergres.com/upec

Supergres hat für einige Feinsteinzeugkollektionen die UPEC Zertifizierung erhalten, das französische Gütezeichen, das auf Basis vorgesehener Prüfungen gemäß der Europäischen Norm EN 14411 und der „Cahiers“ des technischen Instituts CSTB ausgestellt wird. Jedem Artikel wird eine UPEC Klassifizierung zugeordnet, der die Eignung für den Einbau bzw. die Verwendung in verschiedene Zielambientes bescheinigt.

GRADO DI VARIAZIONE CROMATICA - COLOUR SHADE VARIATION
DEGRÉ DE VARIATION CROMATIQUE - GRAD DER FARBABWEICHUNG

Ogni prodotto si caratterizza per un grado di stonalizzazione variabile da prodotto a prodotto, da colore a colore. Per stonalizzazione s'intende variazione di gradazione cromatica da piastrella a piastrella.

Every product is characterised by colour-shading that can vary from one product to another and from one colour to another. When referring to colour-shading we refer to the chromatic variation of the tile surface.

Chaque produit est caractérisé par un degré de nuance variable d'un produit à l'autre et d'une couleur à une autre. Par nuance, il faut entendre une variation de la gradation de couleur entre un carreau et un autre.

Jedes Produkt kennzeichnet sich durch einen bestimmten Grad an Marmorierung (Schattierung), der sich von Produkt zu Produkt, von Farbe zu Farbe unterscheiden kann. Unter Marmorierung versteht man den Grad der Farbänderung von Fliese zu Fliese.

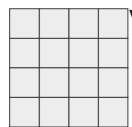

V1

Prodotto monocromatico
Monochromatic product
Produit teinte unie.
Einfarbiges Produkt

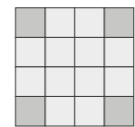

V2

Prodotto con leggera variazione cromatica
Product with a slight chromatic variation
Produit avec une légère variation de couleur
Produkt mit leichter Farbveränderung

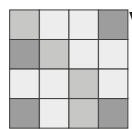

V3

Prodotto con marcata variazione cromatica
Product with a marked chromatic variation
Produit avec une variation de couleur marquée
Produkt mit deutlicher Farbveränderung

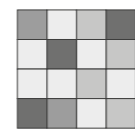

V4

Prodotto con forte stonalizzazione
Product with a strong colour-shading
Produit avec fortes différences de nuances
Produkt mit starker Farbveränderung

Supergres raccomanda l'utilizzo a pavimento di lastre in spessore 6 mm per le sole applicazioni in ambito residenziale, commerciale a traffico leggero e comunque in contesti ove non vi sia passaggio di carichi puntuali pesanti o transito di carrelli a ruote dure.

Le lastre a 6mm, grazie al loro spessore ridotto, sono particolarmente indicate per la posa su pavimenti o rivestimenti preesistenti in marmo, pietra naturale, ceramica, senza la necessità di demolire la pavimentazione sottostante. Tale pavimentazione preesistente dovrà però essere planare, stabile, rigida e priva di rotture. In tutti questi casi sarà necessario valutare attentamente, assieme al progettista della pavimentazione, l'idoneità del sottofondo. In caso di dubbio sarà necessario valutare la necessità della demolizione e/o l'utilizzo di spessori tradizionali.

Supergres sconsiglia la posa delle lastre in 6 mm di spessore direttamente su massetto in quanto tale applicazione è fortemente condizionata dall'esecuzione ottimale del massetto stesso, dalla sua completa stagionatura, dal rispetto degli opportuni giunti di dilatazione nonché dalla posa effettuata a "regola d'arte". Pertanto in caso di posa diretta su massetto, Supergres suggerisce l'utilizzo del gres porcellanato a spessore tradizionale.

In generale, per l'applicazione a pavimento delle lastre in spessore 6mm, l'adesivo (da scegliere insieme al progettista in base alle caratteristiche del cantiere) dovrà essere applicato secondo il metodo della doppia spalmatura, al fine di assicurare la perfetta distribuzione dello stesso e di garantire un'adesione ottimale, evitando la formazione di eventuali vuoti che potrebbero essere causa di rotture.

Supergres stresses that slabs 6 mm in thickness may only be used as flooring in residential and commercial environments that are subject to light traffic, and furthermore, in contexts where there is no circulation of heavy loads or hard-tyre trolleys.

Thanks to the reduced thickness, the 6 mm slabs are a good solution for laying over pre-existing floors or tiling in marble, natural stone or ceramics, and avoid the necessity of demolishing the underlying floor. Such preexisting flooring must, however, be even, stable, rigid and without breakages. Even if the floor conforms to all the above conditions, it is still necessary, together with the flooring project manager, to evaluate the suitability of the underlying layer. If there are any doubts, the need for demolition and/or the use of traditional thickness must be evaluated.

Supergres does not recommend the installation of 6 mm thickness on a slab since the results of installation strictly relate to the condition - excellent - of the slab, to its seasoning, to the provision of expansion joints, as well as to perfect installation in accordance to "the rules of the trade". If you are tiling a new slab, Supergres recommends the use of porcelain stoneware with a standard thickness.

In general, when laying a floor of 6 mm thick slabs, the adhesive (to be selected together with the project manager based on the characteristics of the construction) must be applied using the double bonding technique, aimed at ensuring the perfect distribution of the adhesive to guarantee the best bond, avoiding the presence of any hollows that could cause breakages.

Supergres recommande l'utilisation au sol de plaques de 6 mm d'épaisseur uniquement pour des applications dans un contexte résidentiel et commercial à faible affluence ainsi que dans des contextes dépourvus de passages de charges ponctuelles lourdes ou de chariots à roues dures.

Les plaques de 6 mm d'épaisseur, grâce à leur épaisseur réduite, sont particulièrement adaptées à une pose sur des sols ou des revêtements préexistants en marbre, en pierre naturelle et en céramique, sans impliquer la démolition de la sous-couche. Cette sous-couche préexistante devra toutefois être plane, stable, rigide et privée de ruptures. Il sera dans tous les cas nécessaire d'évaluer attentivement, avec le concepteur du sol, la conformité de la sous-couche. En cas de doute, il sera nécessaire d'évaluer la nécessité de la démolition et/ou l'utilisation d'épaisseurs traditionnelles. Supergres déconseille la pose directe de plaques de 6mm d'épaisseur sur une chape car le résultat dépend de la bonne exécution de la chape, de son séchage complet, du respect des joints de dilatation ainsi que de la pose effectuée selon les règles de l'art. Par conséquent, pour une pose directe sur une chape, Supergres préconise un carrelage en grès cérame d'une épaisseur traditionnelle.

En général, pour l'application au sol des plaques de 6 mm d'épaisseur, l'adhésif (à choisir avec le concepteur en fonction des caractéristiques du chantier) devra être appliqué suivant la méthode du double encollage afin de garantir non seulement la répartition parfaite de ce dernier mais aussi une adhérence optimale, en évitant ainsi la formation de vides éventuels qui pourrait provoquer des ruptures.

Supergres empfiehlt die Verwendung von Platten mit Stärke 6 mm als Bodenbelag nur für Anwendungen im Privatbereich und in Gewerbe- und Objektbereichen mit geringer Trittbelastung, oder in Bereichen, in denen zumindest keine Rollwagen mit harten Rädern zum Einsatz kommen oder schwere punktuelle Belastungen auftreten.

Die 6 mm starken Platten eignen sich aufgrund ihrer geringen Stärke besonders für die Verlegung auf bestehenden Bodenbelägen oder Wandverkleidungen aus Marmor, Naturstein, Keramik, ohne dass der darunterliegende Belag zuvor entfernt werden muss. Dieser bereits vorhandene Boden muss jedoch eben, stabil, hart und bruchstabil sein. In all diesen Fällen muss die Eignung des Untergrundes gemeinsam mit dem Architekten oder Planer zuvor sorgfältig geprüft werden. Im Zweifelsfall muss die Notwendigkeit einer Entfernung des bestehenden Bodenbelags und/oder die Verwendung herkömmlicher Stärken in Erwägung gezogen werden.

Supergres rät davon ab, 6mm starken Platten direkt auf Estrich zu verlegen, da eine solche Anwendung stark von einer optimalen Anfertigung des Estrichs selbst abhängig ist, sowie von seiner kompletten Belegreife, der Einhaltung der notwendigen Dehnungsfugen, sowie von einer „fachgerechten“ Verlegung. Deshalb empfiehlt Supergres im Falle einer direkten Verlegung auf Estrich, Steinzeug mit traditioneller Dicke zu verwenden.

Im Allgemeinen muss bei der Verlegung von 6 mm starken Platten als Bodenbelag der Klebstoff (der zusammen mit dem Planer nach den Eigenschaften des Verwendungsorts ausgewählt wird) doppelt aufgetragen werden (sowohl auf dem Untergrund als auch auf der Rückseite der Platte), um eine perfekte Verteilung und eine optimale Haftung zu gewährleisten und die Bildung von Hohlräumen zu vermeiden, die zu Bruch führen könnten.



IGIENICA
Hygienic
Hygiénique
Hygienisch

La ceramica è facile da pulire, igienica e pratica; basta un semplice detergente neutro per rimuovere lo sporco e facilmente ritorna alla sua bellezza originaria.

Ceramic material is easy to clean, hygienic and practical; all it takes is a simple, neutral detergent to remove dirt and restore it to its original splendour.

La céramique est facile à nettoyer, hygiénique et pratique. Il suffit d'un simple détergent neutre pour éliminer la saleté et la céramique retrouve sa beauté initiale.

Keramik ist pflegeleicht, hygienisch und praktisch; ein einfacher Neutralreiniger genügt, um Schmutz zu entfernen und die Keramik erhält ihre ursprüngliche Schönheit zurück.



SALUBRE
Healthy
Salubre
Nicht
Gesundheitsschädigend

Grazie alle sue caratteristiche fisiche la ceramica non rilascia alcuna sostanza nociva o VOC (sostanze organiche volatili) nell'ambiente in cui viviamo. Allo stesso modo non emette odori.

Thanks to its physical characteristics, ceramic material does not release any harmful substances or VOC (volatile organic substances) into the environment we live in, nor does it give off odours.

Grâce à ses caractéristiques physiques, la céramique ne libère aucune substance nocive ou COV (composés organiques volatils) dans l'environnement dans lequel nous vivons. Elle n'émet pas d'odeurs non plus.

Aufgrund ihrer physikalischen Eigenschaften setzt die Keramik keine Schadstoffe oder VOCs (flüchtigen Kohlenwasserstoffe) in die Umwelt frei. Sie gibt auch keine Gerüche ab.



RESISTENTE ALL'USURA
Wear resistant
Résistant à l'usure
Verschleissfest

Il gres porcellanato è un materiale tecnico ultra compatto, altamente resistente all'usura; sopporta bene calpestio, urti, graffi e carichi pesanti.

Porcelain stoneware is an ultra-compact technical material, extremely resistant to wear, tread, shock, scratching and heavy loads.

Le grès cérame est un matériau technique ultra compact, extrêmement résistant à l'usure. Il supporte bien le piétinement, les chocs, les rayures et les charges lourdes.

Feinsteinzeug ist ein ultrakompaktes technisches Material, das sehr widerstandsfähig gegen Verschleiß und Trittbelastung ist und dem Stöße, Kratzer und schwere Lasten nichts ausmachen.



ANTIMACCHIA
Stain resistant
Anti-taches
Fleckabweisend

La ceramica non teme macchie e non viene danneggiata con l'utilizzo di solventi e detersivi.

Ceramic material is resistant to stains and is not damaged by the use of solvents and detergents.

La céramique ne craint pas les taches et l'utilisation de solvants et de détergents ne l'abîme pas.

Keramik ist unempfindlich gegen Flecken und wird durch Lösungs- und Reinigungsmittel nicht angegriffen.



INGELIVA
Frostproof
Ingélif
Frostbeständig

Il gres porcellanato resiste al gelo e a tutti gli attacchi degli agenti atmosferici, ed è quindi il prodotto ideale anche in ambienti esterni.

Porcelain stoneware is resistant to frost and to all kinds of attack from the elements, making it the ideal product also for outdoors.

Le grès cérame résiste au gel et à toutes les attaques des agents atmosphériques. Il est, par conséquent, le produit idéal dans des environnements extérieurs aussi.

Feinsteinzeug ist frost- und witterungsbeständig und somit das ideale Produkt für die Verwendung in Außenbereichen.



VERSATILE
Versatile
Versatile
Vielseitig

La ceramica consente tante variazioni di stile e design, grazie all'ampia disponibilità di formati, spessori, finiture e tinte. Inoltre può essere utilizzata in qualsiasi ambiente, sia a pavimento che a rivestimento, in interno o esterno, in ambienti residenziali o pubblici.

All sorts of style and design variants are possible with ceramics, thanks to the wide availability of different sizes, thicknesses, finishes and colours. It can also be used anywhere, on both floors and walls, indoors or outdoors, in residential or public settings.

La céramique permet de très nombreuses variations de style et de design grâce à la vaste disponibilité de formats, d'épaisseurs, de finitions et de teintes. En outre, elle peut être utilisée dans tous les environnements, aussi bien au sol qu'au mur, à l'intérieur ou à l'extérieur, dans des contextes résidentiels ou publics.

Keramik ermöglicht dank der Verfügbarkeit von vielen Formaten, Stärken, Oberflächen und Farben viele Variationen in Stil und Design. Es kann auch in jeder Umgebung eingesetzt werden, ob auf dem Boden oder an der Wand, im Innen- oder Außenbereich, im Wohnbereich oder in öffentlichen Bereichen.



**PRODOTTO NEL
RISPETTO DELL'AMBIENTE**
**Eco-sustainable
production**
**Produite dans le respect
de l'environnement**
**Umweltfreundliches
Produkt**

Il processo produttivo aziendale impiega un sistema di raccolta e di riutilizzo degli scarti di produzione, delle acque di lavorazione e del calore generato nelle fasi di produzione. In questo modo si limita il consumo di energia e di materie prime, per un'economia più sostenibile e un ridotto impatto ambientale.

The company's production process uses a system that collects and re-uses production waste, processing water and the heat generated during the production process, thus limiting the consumption of energy and raw materials, for a more sustainable economy and lower environmental impact.

Le processus de production de l'entreprise utilise un système de collecte et de réutilisation des déchets de production, des eaux de traitement et de la chaleur générée au cours des phases de production. De cette manière, la consommation en énergie et en matières premières est limitée pour une économie plus durable et un impact environnemental réduit.

Der Produktionsprozess des Unternehmens nutzt ein System zur Sammlung und Wiederverwendung von Produktionsabfällen, Prozesswasser und Wärme, die während der Produktionsphasen entstehen. Dies begrenzt den Verbrauch von Energie und Rohstoffen für eine nachhaltigere Wirtschaft und geringere Umweltbelastungen.

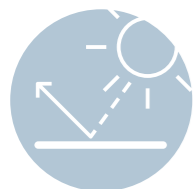

**RESISTENTE
AI RAGGI UV:
COLORI STABILI
NEL TEMPO**
**Resistant to UV rays: lasting
colour stability**
**Résistante
aux rayons UV :
des couleurs stables
au fil du temps**
**UV-beständig:
dauerhafte
Farbstabilität.**

Esposta al sole anche per lungo tempo la ceramica non cambia colore, e mantiene inalterate nel tempo le sue caratteristiche estetiche e tecniche.

Ceramic material does not fade even after lengthy exposure to sunlight, and maintains its aesthetic and technical characteristics over time.

Exposée au soleil, même pendant une longue période, la céramique ne change pas de couleur et conserve ses caractéristiques esthétiques et techniques inchangées au fil du temps.

Keramik, die lange Zeit der Sonne ausgesetzt war, verändert ihre Farbe nicht und behält ihre ästhetischen und technischen Eigenschaften mit der Zeit unverändert bei.



PRODOTTO IGNIFUGO
Fireproof
Produit ignifuge
Feuerfest

Resiste al fuoco e non emette fumi in seguito alla combustione.
Resistant to fire and does not emit smoke upon combustion.
Elle résiste au feu et n'émet pas de fumées suite à la combustion.
Keramik ist feuerbeständig und gibt bei Verbrennung keine Dämpfe ab.



**IDEALE PER
RISCALDAMENTO
A PAVIMENTO**
**Ideal for
underfloor heating**
**Idéale pour
le chauffage au sol**
**Ideal für die
Fußbodenheizung**

Ottimo conduttore di calore, il gres porcellanato si scalda rapidamente e il calore è rilasciato immediatamente nell'ambiente; in questo modo consente di mantenere limitate temperature d'esercizio dell'impianto di riscaldamento.

An excellent conductor of heat, porcelain stoneware warms up quickly and releases heat into the air immediately, making it possible to keep the heating system working temperatures lower.

Excellent conducteur de chaleur, le grès cérame se réchauffe rapidement et la chaleur est immédiatement libérée dans l'environnement. De cette manière, les températures d'exercice de l'installation de chauffage peuvent être limitées.

Als ausgezeichnete Wärmeleiter erwärmt sich Feinsteinzeug schnell und die Wärme wird sofort an die Umgebung abgegeben, sodass die Heizung mit begrenzten Betriebstemperaturen arbeiten kann.

POSA, USO, PULIZIA E MANUTENZIONE

Posa in opera

Al ricevimento del materiale, dopo aver controllato la corrispondenza tra i documenti di consegna e la merce e comunque prima della posa in opera, è importante verificare accuratamente che il tono, il calibro e la scelta del materiale siano conformi. E' inoltre necessario verificare che il materiale sia esente da vizi palesi (così come definiti dalle condizioni generali di vendita e dalla tabella 2 di pag. 366) poiché non potranno essere accettati reclami su materiale già posato i cui difetti fossero visibili prima della installazione.

Premesso che la stonizzazione è una caratteristica propria dei prodotti ceramici, si richiede la verifica del valore V- SHADE delle piastrelle che si dovranno installare. Per ottenere comunque il miglior risultato estetico possibile, posare il materiale attingendo i pezzi da più scatole, in modo da ottenere una miscelazione ottimale.

Per prodotti venati, come per le pietre naturali, si raccomanda di disporre la venatura delle lastre in modo da ottenere il migliore effetto estetico e cromatico.

Il committente finale dovrà assicurare, per quanto di sua pertinenza, condizioni microclimatiche e di illuminazione tali da assicurare la possibilità per il posatore di condurre le operazioni di installazione in modo affidabile, controllando pertanto i materiali e l'opera in corso di realizzazione, come prescritto in precedenza.

Si consiglia di posare a colla con l'utilizzo di collanti specifici ad elevate prestazioni. Si ricorda che, al momento della posa, il sottofondo deve essere stabile, asciutto e maturo. Comunque è necessario seguire le istruzioni dei produttori dei materiali per sottofondi e collanti specifici utilizzati. Gli adesivi cementizi devono essere applicati a temperatura ambiente, ed in genere compresa tra +5° C e + 30/35° C. I collanti più adatti alla posa dei materiali a marchio Supergres, si possono identificare sulla base della Normativa Europea attualmente in vigore EN12004.

Durante la posa è necessario non segnare il materiale sulla superficie di utilizzo con matite (grafite) o pennarelli indelebili, in particolar modo sui prodotti levigati.

Pur non essendo necessario bagnare le piastrelle prima della posa, nel caso il retro della piastrella si presenti molto polveroso è comunque consigliabile un rapido lavaggio in acqua pulita.

Nel periodo compreso tra la conclusione della posa e la consegna al committente finale, la piastrellatura ceramica dovrà essere mantenuta pulita e libera da cemento, sabbia, malta e da qualsiasi altro materiale che possa causare macchie e/o fenomeni di abrasione meccanica superficiale. E' necessario proteggere la posa da danni o contaminazioni potenzialmente apportate a seguito di una prevedibile frequentazione di altri operatori quali imbianchini, elettricisti, falegnami etc.

Per la posa "a correre" si raccomanda di sfalsare le piastrelle al massimo di 20 cm. Per i materiali rettificati la fuga minima prescritta è di 2 mm (questo tipo di posa consente una maggior presa del fugante sui fianchi delle lastre, un maggior assorbimento di eventuali movimenti del sottofondo ed una compensazione delle lastre). Per quelli non rettificati si prescrive una fuga di almeno 5mm.

Supergres non accetta sostanziazioni per posa di materiale rettificato con fughe inferiori ai 2 mm.

I prodotti in gres porcellanato Supergres, pur essendo materiali molto resistenti, possono essere sagomati (per realizzazioni di top, scale...), perforati per l'installazione di impianti tecnico-sanitari, utilizzando appositi dischi diamantati ed attrezzature idonee.

Il taglio delle piastrelle può provocare la formazione di polvere di silice (SiO2), consigliamo l'utilizzo di taglierine manuali in ambiente aperto o preferibilmente macchine ad umido. In cantiere è importante proteggere le vie respiratorie con mascherine, gli occhi con occhiale e le mani con guanti da lavoro. Nella movimentazione manuale delle piastrelle verificare preventivamente il peso delle stesse per evitare sforzi eccessivi. La movimentazione manuale dei carichi deve avvenire nel rispetto delle normative nazionali in vigore.

In cantiere è estremamente importante differenziare tutte le tipologie di rifiuti per permetterne il conferimento e quando possibile il recupero. Consigliamo di conferire i materiali derivanti dalla demolizione di pavimenti e rivestimenti nelle stazioni ecologiche, in modo da garantirne uno smaltimento ecosostenibile.

AVVERTENZA:

SUPERGRES A MATERIALE GIA' POSATO:

- **NON ACCETTA CONTESTAZIONI DOVUTI A VIZI PALESI, COSI' COME DEFINITI NELLA TABELLA 2 PAG. 366**

- **NON RISPONDE SULLA QUALITA' DELL'OPERA PIASTRELLATA MA SOLAMENTE SULLE CARATTERISTICHE DEL MATERIALE FORNITO.**

E' BENE CONSERVARE AL TERMINE DELLA POSA, ALCUNE PIASTRELLE DI SCORTA PER EVENTUALI RIPARAZIONI O ANCHE PER DISPORRE DI UN CAMPIONE RAPPRESENTATIVO DEL MATERIALE IN CASO DI CONTESTAZIONE

Giunti e stuccature

Negli ambienti di grande dimensione è assolutamente necessario posizionare dei giunti di dilatazione con regolarità; mentre, per i piccoli ambienti è sufficiente lasciare un leggero stacco fra piastrellato e muri perimetrali, che verrà coperto dal battiscopa. In ogni caso è necessaria la supervisione del progettista o del direttore di cantiere che verifichi che l'installazione rispetti le normative vigenti nei singoli paesi.

Per l'utilizzo di stucchi epossidici o con aggiunte di resine o similari, si consiglia di seguire con attenzione le indicazioni dei produttori perché il loro rapido indurimento richiede maggiori attenzioni. Riteniamo inoltre sia importante fare una prova preventiva di pulizia su una porzione di pavimento.

In modo particolare per i prodotti lappati e levigati suggeriamo l'utilizzo di stucchi in cadenza di colore con la piastrella (es. evitare piastrella bianca con stucco nero).

Dopo la stuccatura delle piastrelle è importante, a stucco ancora fresco, rimuovere immediatamente in modo accurato con spugna ed abbondante acqua lo stucco in eccesso.

E' comunque indispensabile alcuni giorni dopo la posa, a fughe asciutte, effettuare la pulizia di fondo mediante l'utilizzo di acidi tamponati (si veda il capitolo seguente: Pulizia "dopo posa") al fine di rimuovere completamente tutti i residui di cantiere.

Alcuni esempi di detergenti a base "acida" specifici per la pulizia dopo posa sono:

- **DETERDEK PRO FILA INDUSTRIA CHIMICA** - www.filachim.com
- **DELTA PLUS ECO KERAKOLL** - www.kerakoll.com
- **KERANET MAPEI** - www.mapei.it
- **SOLVACID GEAL** - www.geal-chim.it
- **DISYCOTT FABER** - www.faberchimica.com

Pulizia straordinaria "dopo posa"

Gres porcellanato

La pulizia "dopo posa" è obbligatoria a fine cantiere.

La rimozione inadeguata o tardiva dei residui della stuccatura utilizzata per le fughe può lasciare alonature difficili da rimuovere e

creare sulla pavimentazione un film cementizio capace di assorbire ogni forma di sporco.

E' indispensabile sciogliere ed eliminare completamente questi residui con l'utilizzo di acidi tamponati diluiti in acqua (attenersi sempre alle istruzioni d'uso sulle confezioni dei prodotti utilizzati), che dovranno essere totalmente rimossi successivamente in breve tempo con abbondante risciacquo di tutto il pavimento.

Si consiglia di ripetere l'operazione di lavaggio e risciacquo fino alla completa rimozione di ogni alone o residuo.

Suggeriamo di eseguire un lavaggio preliminare su una superficie campione di alcuni metri quadrati; in caso di esito positivo, si estenderà la pulizia su tutta la superficie.

Una volta effettuato il lavaggio sopraccitato, è necessario eseguire un lavaggio basico o alcalino utilizzando detersivi sgrassanti.

Questo perché il lavaggio acido può lasciare untuosità sul pavimento che potrebbe contribuire a trattenere lo sporco.

Prima di utilizzare questi prodotti leggere attentamente le etichette sulle confezioni per farne un uso sicuro ed efficace.

Rivestimento pasta bianca

Il lavaggio dopo la posa è una fase di fondamentale importanza per tutti gli interventi successivi di manutenzione: con tale intervento si eliminano i residui di posa ed il normale sporco di cantiere come malta, colla, pittura etc. Una volta trascorsi i tempi di stagionatura dello stucco, procedere ad una pulizia con un detergente neutro attenendosi scrupolosamente alle istruzioni d'uso indicate sulla confezione dal produttore.

Decorati ed inserti speciali con applicazioni materiche e/o metalli preziosi (oro – argento)

Bisogna prestare molta attenzione nella fase della pulizia così come nella fase di posa; evitare assolutamente l'uso di prodotti abrasivi che potrebbero graffiare e danneggiare la superficie. Per la pulizia Supergres consiglia di utilizzare unicamente panni morbidi con acqua calda e alcool.

Pulizia quotidiana

Dopo avere effettuato la pulizia "dopo posa" (capitolo precedente), per la pulizia quotidiana si consiglia l'utilizzo di un detergente neutro.

Sono da evitare i detergenti in commercio contenenti cere e additivi lucidanti che possono depositare sul pavimento patine indesiderate. E' sconsigliato vivamente l'impiego di cere, saponi oleosi, impregnanti e trattamenti vari (idro-oleo repellenti) sul prodotto Supergres, la cui applicazione non è necessaria. In presenza di suddetti trattamenti occorre innanzitutto asportarli dal pavimento utilizzando i prodotti specifici, seguendo le istruzioni riportate dal produttore.

In caso di patine create da sapone, calcare, sporco, occorre invece utilizzare un detergente acido, opportunamente diluito in acqua (attenersi alle istruzioni sull'etichetta del prodotto).

E' opportuno segnalare che l'acido fluoridrico (HF) e derivati possono danneggiare irrimediabilmente le piastrelle.

Per la pulizia ordinaria Supergres consiglia l'utilizzo di varechina o ammoniaca, opportunamente diluite in acqua.

Tutte le superfici lappate o levigate necessitano di un utilizzo di attrezzature non abrasive durante la fase di pulizia per prevenire opacizzazioni e graffiature.

Si consiglia inoltre l'asciugatura del pavimento onde evitare la formazione di aloni.

Pulizie straordinarie

In caso di macchie particolari e/o particolarmente tenaci, è consigliabile l'uso di detergenti specifici, come indicato nella Tabella 1: "prodotti per la pulizia". Non va inoltre dimenticato che la rimozione di qualsiasi tipo di macchia è più agevole quando questa è ancora fresca.

E' importante fare sempre un test preventivo prima dell'uso dei prodotti detergenti, in particolare su gres porcellanato lappato o levigato.

Tab. 1 - Prodotti per la pulizia

TIPO DI SPORCO	SOLUZIONE	DETERGENTI / PRODUTTORE
CALCARE, CARBONE, CEMENTO, GESSO, MALTA, MATITA, RESIDUI METALLICI, RUGGINE, STUCCO CEMENTIZIO, STUCCO COLORATO, TEMPERA MURALE	SOLUZIONE ACIDA	DETERDEK PRO / FILA SOLVACID / GEAL CEMENT REMOVER / FABER KERANET / MAPEI DELTA PLUS ECO / KERAKOLL
BIRRA, CAFFE', COCA COLA, VINO, GELATO, PNEUMATICO, GRASSO, KETCHUP, MAIONESE, MARPELLATA, MOSTARDA, ROSSETTO, SUOLE DI GOMMA, TINTURA PER CAPELLI, URINA, VOMITO	SOLUZIONE ALCALINA	PS87 PRO / FILA DETERFLASH / GEAL TILE CLEANER / FABER AMMONIACA / UNIVERSALE
ALONATURA VENTOSE, CATRAME, CERA DI CANDELA, CERA PROTETTIVA, COLLA, GOMMA DA MASTICARE, INCHIOSTRO, NASTRO ADESIVO, OLI, PENNARELLO, RESINE, SMALTO PER UNGHIE, SIGARETTA,	SOLVENTE	FILA SOLV / FILA ALKALIN CLEANER / FABER ACETONE / UNIVERSALE TRIELINA / UNIVERSALE

Per eventuali richieste specifiche contattare:

FILA (www.filasolutions.com), **KERAKOLL** (www.kerakoll.com), **MAPEI** (www.mapei.it), **GEAL** (www.geal-chim.it), **FABER** (www.faberchimica.com)

Laying

When you receive the material ordered, after having checked that the goods delivered correspond to the shipping documents, and in any case before laying, it is important to check carefully that the tone, caliber and grade of material match your order. It is also necessary to check that the material presents no visible defects (as defined by the general terms of sale and by table 2 - page 366), as no complaints will be accepted once the material has been laid, if such defects were visible beforehand.

As the shading is a characteristic of ceramic products, we request that you check the value V- SHADE of the tiles you wish to fit. To obtain the best aesthetic result possible, the material should be laid using tiles from different boxes and thus obtain a varied mixture.

For products with vein markings, as with natural stone effect tiles, we recommend arranging the vein markings of the slabs in such a way that the best aesthetic and chromatic effect is obtained.

The end customer must assure that the environmental and lighting conditions for which he is responsible are suitable to allow the tile fitter to carry out his work in a reliable manner. He must therefore check the materials and the tile-laying operation, as described above.

We recommend that the tiles are glued to the substrate using specific, high-performance adhesives. Please remember that the substrate must be stable, dry and properly prepared for laying. It is necessary in any case to follow the instructions provided by the manufacturers of substrates and the specific adhesives used. Cement-based adhesives must be applied at room temperature, generally between +5° and 30/35° C.

The most suitable adhesives for the laying of Supergres materials should be labelled according to the currently valid European Standard, EN12004.

When laying the material, no marks should be made on the surface with pencils (graphite) or permanent markers, particularly on polished surfaces.

Although it is not necessary to dampen the tiles before laying, if the tiles are very dusty, it is advisable to rinse quickly in clean water. In the period after the surfaces have been tiled until they are handed over the end customer, the ceramic tiles must be kept clean and free of cement, sand, mortar and any other material that might cause stains and/or mechanical surface abrasion. The finished surfaces must be protected from potential damage or contaminations owing to the foreseeable presence of other tradesman such as painters and decorators, electricians, carpenters etc.

For continuous surfaces we recommend staggered layouts, with a distance between edges of no more than 20 cm. For rectified materials, the minimum joint prescribed is 2 mm (this method allows the grout to have a better grip on the sides of the slabs, greater absorption of any movements of the substrate and consequently of the slabs themselves). For non-rectified materials the minimum joint required is 5 mm.

Supergres will not accept any complaints for rectified tiles that have been laid leaving joints of less than 2 mm.

Cutting tiles can result in the formation of silica dust (SiO2), we recommend the use of manual cutters in an open environment or preferably wet machines. On the construction site, wear a mask to protect the respiratory tract, goggles to protect your eyes and work gloves to protect your hands. When handling tiles manually, check their weight beforehand to avoid excessive strain. Manual handling of loads must be carried out in accordance with the national regulations in force. On the construction site, it is extremely important to separate all types of waste for their separate collection and, when possible, recovery. We recommend that materials resulting from the demolition of floor and wall coverings be taken to the waste separation areas to ensure sustainable disposal.

WARNING:

FOR MATERIAL THAT HAS ALREADY BEEN LAID, SUPERGRES:

- **DOES NOT ACCEPT ANY COMPLAINTS FOR VISIBLE DEFECTS, AS DEFINED IN TABLE 2 PAGE 366**

- **DOES NOT ACCEPT LIABILITY FOR THE QUALITY OF THE TILED SURFACE BUT ONLY FOR THE CHARACTERISTICS OF THE MATERIAL SUPPLIED.**

ONCE THE MATERIAL HAS BEEN LAID, IT IS WISE TO KEEP ASIDE A FEW TILES FOR POSSIBLE FUTURE REPAIRS OR TO HAVE A SAMPLE OF THE MATERIAL IN THE EVENT OF COMPLAINTS

Joints and grouting

In large, open spaces it is absolutely essential to position the expansion joints at regular intervals; in smaller rooms, on the other hand, it is sufficient to leave a slight space between the tiled surface and the walls around the room, which will be hidden by the skirting board. The tiles must be laid under the supervision of a planner or site manager, who must ensure that the work is carried out in accordance with the standards in force in the respective country.

For the use of epoxy grouting or the addition of resins or similar substances, it is important to properly follow the manufacturer's instructions as the fact such products harden more quickly requires greater attention. We also believe it is important to carry out a cleaning test on a part of the flooring.

Especially for lapped and polished products, we suggest using grouts that match the colour of the tiles (e.g. avoid using black grout with white tiles).

It is important to remove any excess grouting immediately and accurately after application while still fresh, using a sponge and plenty of water.

A few days after laying, once the joints are completely dry, it is essential to thoroughly clean the tiled surface using buffered acids (see the following chapter: Cleaning "after laying"), in order to completely remove all residual substances.

Some examples of "acid"-based detergents designed specifically for this purpose are:

- **DETERDEK PRO FILA INDUSTRIA CHIMICA** - www.filachim.com
- **DELTA PLUS ECO KERAKOLL** - www.kerakoll.com
- **KERANET MAPEI** - www.mapei.it
- **SOLVACID GEAL** - www.geal-chim.it
- **DISYCOTT FABER** - www.faberchimica.com

Extraordinary cleaning "after installation"

Porcelain stoneware

Properly cleaning the tiles after they have been laid is crucial.

If residues of the grouting used is removed inaccurately or too late, it may leave stains that are difficult to remove, and create a film of cement on the floor that can absorb any form of dirt.

It is essential to loosen and eliminate these residues completely using buffered acids diluted in water (always follow the instructions provided on the box), which will then have to be removed quickly by rinsing the entire floor with plenty of clean water. We advise repeating this washing and rinsing operation several times until any stains or residues are completely removed.

We suggest carrying out a preliminary test on a sample surface of several metres; if the results are good, you can then clean the entire surface.

After this, the floor must then be cleaned thoroughly with a basic or alkaline detergent to degrease the surface. This is because acidic detergents may leave a film of grease on the floor that could trap dirt.

Before using these products, read the labels on the packaging carefully to ensure safe and effective use

White body wall coverings

It is essential to clean the tiles after laying for the purpose of all subsequent maintenance operations: in this way, any residues of grouting as well as the normal dirt created during building works are eliminated, such as mortar, adhesive, paint etc. Once the grouting has properly dried, clean the surface with a neutral detergent, complying strictly with the instructions for use on the box or package.

Decorative trims and special inserts with relief patterns and/or precious metals (gold – silver)

Great attention must be paid during both the cleaning phase and the laying phase; it is vital to avoid the use of abrasive products that might scratch or damage the surface. For the cleaning of surfaces in Supergres, we recommend using exclusively a soft cloth with warm water and alcohol.

Everyday cleaning

Once the surface has been cleaned "after laying" (see previous chapter), for everyday cleaning we recommend the use of a neutral detergent.

Avoid using widely available detergents containing waxes and polishing additives that can deposit an undesired coating on the flooring. We strictly advise against the use of waxes greasy soaps, fillers and various treatments (water and oil repellent) on the Supergres product, as they are not necessary. If the above treatments have been applied they will firstly need to be removed from the flooring using specific products following the manufacturer's instructions.

In the case of coatings created by soap, lime scale or dirt, you will need an acidic detergent, diluted in water as appropriate (always follow the instructions on the label).

It should be noted that is hydrofluoric acid (HF) and its derivatives may damage the tiles permanently.

For routine cleaning operations we recommend the use of bleach or ammonia, appropriately diluted in water.

For all lapped or polished surfaces, the use of non-abrasive cleaning equipment is necessary to prevent the surface from losing its shine or becoming scratched.

We also recommend leaving the floor to dry properly to prevent stains from forming.

Extraordinary cleaning

In the case of particular and/or particularly stubborn stains, we recommend using specific detergents as those indicated in Table 1: "cleaning products". It should furthermore not be forgotten that the removal of any type of stain is easier when the stain is still fresh.

It is always important to test the detergents on a small area before applying to the entire surface, particularly in the case of porcelain stoneware with a lapped or polished finish.

Table 1 - Cleaning products

TYPE OF DIRT	SOLUTION	DETERGENTS/ MANUFACTURER
LIMESCALE, CARBON, CEMENT, CHALK, MORTAR, PENCIL, METAL RESIDUE, RUST, CEMENT GROUT, COLOURED GROUT, WALL TEMPERA	ACID SOLUTION	DETERDEK PRO / FILA SOLVACID / GEAL CEMENT REMOVER / FABER KERANET / MAPEI DELTA PLUS ECO / KERAKOLL
BEER, COFFEE, COKE, WINE, ICE CREAM, TIRE MARKS, FAT, KETCHUP, MAYONNAISE, JAM, MUSTARD, LIPSTICK, RUBBER SOLES, HAIR DYE, URINE, VOMIT,	ALKALINE SOLUTION	PS87 PRO / FILA DETERFLASH / GEAL TILE CLEANER / FABER AMMONIACA / UNIVERSALE
STAINS FROM SUCTION CUPS, TAR, CANDLE WAX, PROTECTIVE WAX, GLUE, CHEWING GUM, INK, ADHESIVE TAPE RESIDUE, OILS, MARKER PEN, RESINS, NAIL POLISH, CIGARETTE	SOLVENT	FILA SOLV / FILA ALKALIN CLEANER / FABER ACETONE / UNIVERSALE TRIELINA / UNIVERSALE

For any specific request contact:

FILA (www.filasolutions.com), **KERAKOLL** (www.kerakoll.com), **MAPEI** (www.mapei.it), **GEAL** (www.geal-chim.it), **FABER** (www.faberchimica.com)

POSE, UTILISATION, NETTOYAGE ET ENTRETIEN

CERAMICHE SUPERGRES

Pose

Au moment de la réception du matériau, après avoir contrôlé la correspondance entre les documents de livraison et la marchandise et dans tous les cas avant la pose, il est important de vérifier avec minutie que le ton, le calibre et le choix du matériau sont conformes. En outre, il est nécessaire de vérifier que le matériau est exempt de vices apparents (définis par les conditions générales de vente et par le tableau 2 à la page 366) dans la mesure où aucune réclamation concernant un matériau déjà posé, dont les vices étaient visibles avant l’installation, ne pourra être acceptée.

En partant du principe que le dénuçage est une caractéristique propre aux produits céramiques, il est demandé de vérifier la valeur V-SHADE des carreaux qui devront être installés. Afin d’obtenir le meilleur résultat esthétique possible, il faut poser le matériau en prenant des carreaux provenant de boîtes différentes de manière à obtenir un mélange parfait.

Pour les produits à veinures, comme les pierres naturelles, il est recommandé de disposer la veinure des plaques de manière à obtenir le plus bel effet esthétique et chromatique.

Le client final devra garantir, dans la mesure du possible, des conditions microclimatiques et d’éclairage permettant au poseur de conduire les opérations d’installation de manière fiable, en contrôlant, par conséquent, les matériaux et l’ouvrage en cours de réalisation, comme indiqué précédemment.

Il est conseillé de poser avec de la colle en utilisant des adhésifs spécifiques à hautes prestations. Il est rappelé que, au moment de la pose, la sous-couche doit être stable, sèche et adaptée. Il est dans tous les cas nécessaire de suivre les instructions des fabricants des matériaux pour les sous-couches et les adhésifs cimentaires spécifiques utilisés. Les adhésifs cimentaires doivent être appliqués à une température ambiante, généralement entre +5° C et + 30/35° C.

Les adhésifs les plus adaptés à la pose des matériaux de la marque Supergres peuvent être identifiés à partir de la Norme Européenne actuellement en vigueur EN12004.

Durant la pose, il est nécessaire de ne pas écrire sur la surface d’utilisation du matériau à l’aide de crayons (graphites) ou de marqueurs indélébiles, notamment sur celle des produits polis.

Bien qu’il ne soit pas nécessaire de mouiller les carreaux avant la pose, il est toutefois conseillé de laver rapidement avec de l’eau propre le dos du carreau si celui-ci est poussiéreux.

Dans la période comprise entre la conclusion de la pose et la livraison au client final, le carrelage céramique devra être maintenu propre et dépourvu de ciment, sable, mortier et de tout autre matériau pouvant entraîner des taches et/ou des phénomènes d’abrasion mécanique superficielle. Il est nécessaire de protéger la pose vis-à-vis des dommages ou des contaminations provenant, éventuellement, d’un passage prévisible d’autres ouvriers tels que des peintres en bâtiment, des électriciens, des menuisiers, etc.

Pour la pose dite à fond perdu, il est recommandé de décaler les carreaux de 20 cm au maximum. Pour les matériaux rectifiés, le joint minimum prescrit est de 2 mm (ce type de pose permet une plus grande prise du jointoyant sur les bords des carreaux, une plus grande absorption des éventuels mouvements de la sous-couche et une compensation des carreaux). Pour les carreaux non rectifiés, il faut réaliser un joint d’au moins 5 mm.

Supergres n’accepte pas les contestations relatives à la pose de matériau rectifié avec des joints inférieurs à 2 mm.

La découpe des carreaux peut entraîner la formation de poussière de silice (SIO2). Nous conseillons d’utiliser des outils de coupe manuels dans des espaces ouverts ou, de préférence, des outils de coupe à eau. Sur le chantier, il est important de protéger les voies respiratoires avec des masques, les yeux avec des lunettes et les mains avec des gants de travail. Lors de la manutention manuelle des carreaux, vérifier au préalable le poids des paquets afin d’éviter des efforts excessifs. La manutention manuelle des charges doit se faire dans le respect de la réglementation nationale en vigueur. Sur le chantier, il est extrêmement important de différencier tous les types de déchets afin de permettre leur collecte et, si possible, leur récupération. Nous conseillons d’apporter les matériaux provenant de la démolition de sols et revêtements muraux dans un centre de tri de manière à garantir une élimination respectueuse de l’environnement.

AVERTISSEMENT :

SUPERGRES, CONCERNANT LE MATÉRIAU DÉJÀ POSÉ,

- N’ACCÉPTE PAS LES CONTESTATIONS DUES À DES VICES APPARENTS, DÉFINIS DANS LE TABLEAU 2 À LA PAGE 366

- N’EST PAS RESPONSABLE DE LA QUALITÉ DU CARRELAGE RÉALISÉ, MAIS UNIQUEMENT DES CARACTÉRISTIQUES DU MATÉRIAU FOURNI.

IL EST CONSEILLÉ DE CONSERVER, AU TERME DE LA POSE, PLUSIEURS CARREAUX À METTRE DE CÔTÉ EN VUE DE RÉPARATIONS ÉVENTUELLES OU AFIN DE DISPOSER AUSSI D’UN ÉCHANTILLON REPRÉSENTATIF DU MATÉRIAU EN CAS DE CONTESTATION.

Joints et jointoiements

Dans les espaces de grandes dimensions, il est absolument nécessaire de positionner des joints de dilatation avec régularité, tandis que pour les petits espaces, il est suffisant de laisser un léger espace entre le carrelage et les murs périmétraux, qui sera ensuite recouvert par la plinthe. La supervision du concepteur ou du directeur de chantier est dans tous les cas nécessaire pour vérifier que l’installation respecte les normes en vigueur dans chaque pays.

Pour l’utilisation de mastics époxys ou avec des adjonctions de résines ou similaires, il est conseillé de suivre avec attention les indications des fabricants car le durcissement rapide de ces derniers requiert des attentions supplémentaires. Il est également jugé important de faire, au préalable, un essai de nettoyage sur une portion du sol.

Notamment, pour les produits lustrés et polis, il est suggéré d’utiliser des mastics dont la couleur est en harmonie avec celle du carreau (ex. Éviter un carreau blanc avec un mastic noir).

Après le jointoiement des carreaux, il est important, lorsque le mastic est encore frais, d’enlever immédiatement avec soin le mastic en excès à l’aide d’une éponge et de beaucoup d’eau.

Il est dans tous les cas indispensable, quelques jours après la pose, lorsque les joints sont secs, d’effectuer le nettoyage de fond en utilisant des acides tamponnés (voir le chapitre suivant intitulé : Nettoyage « après la pose ») afin d’enlever complètement tous les résidus des opérations de chantier.

Voici quelques exemples de détergents à base « acide » spécifiques pour le nettoyage après la pose :

- DETERDEK PRO FILA INDUSTRIA CHIMICA** - www.filachim.com
- DELTA PLUS ECO KERAKOLL** - www.kerakoll.com
- KERANET MAPEI** - www.mapei.it
- SOLVACID GEAL** - www.geal-chim.it
- DISYCOTT FABER** - www.faberchimica.com

Nettoyage extraordinaire « de fin de pose »

Grès cérame

Le nettoyage « après la pose » est obligatoire à la fin des travaux.

Le retrait inadapté ou tardif des résidus du jointoiement utilisé pour les joints peut laisser des auréoles difficiles à enlever et créer sur

le sol un film cimentaire capable d’absorber les saletés en tout genre.

Il est indispensable de détacher et d’éliminer complètement ces résidus à l’aide d’acides tamponnés dilués dans l’eau (toujours se conformer aux instructions d’utilisation sur les emballages des produits utilisés) qui devront ensuite être éliminés complètement et rapidement lors du rinçage abondant de l’ensemble du sol.

Il est conseillé de répéter l’opération de lavage et de rinçage jusqu’à l’élimination complète de toutes les auréoles ou de tous les résidus.

Il est suggéré d’effectuer un lavage préliminaire sur une surface échantillon de plusieurs mètres carrés. Dans le cas d’un résultat positif, le nettoyage pourra être étendu sur l’ensemble de la surface. Après avoir effectué le nettoyage susmentionné, il est nécessaire d’effectuer un lavage basique ou alcalin en utilisant des détersifs dégraissants. Cela car le lavage acide peut laisser une patine sur le sol qui pourrait contribuer à retenir la saleté.

Avant d’utiliser ces produits, lire attentivement les étiquettes sur les emballages afin de les utiliser de manière sûre et efficace.

Revêtement en pâte blanche

Le lavage après la pose est une phase d’une importance fondamentale pour toutes les interventions successives d’entretien : il permet d’éliminer les résidus de pose et la saleté qui viennent inévitablement des travaux comme le mortier, la colle, la peinture, etc. Une fois que les délais de séchage du mastic sont écoulés, il faut procéder à un nettoyage à l’aide d’un détergent neutre en respectant scrupuleusement les instructions d’utilisation indiquées par le fabricant sur l’emballage.

Décorations et insertions spéciales avec applications de matières et/ou de métaux précieux (or – argent)

Il faut prêter une grande attention lors de la phase de nettoyage et de la phase de pose. Éviter absolument l’utilisation de produits abrasifs qui pourraient rayer et endommager la surface. Pour le nettoyage, Supergres conseille d’utiliser uniquement des chiffons doux avec de l’eau chaude et de l’alcool.

Nettoyage quotidien

Après avoir effectué le nettoyage « après la pose » (chapitre précédent), l’utilisation d’un détergent neutre est conseillée pour le nettoyage quotidien.

Les détergents vendus dans le commerce, contenant des cires et des additifs brillants qui peuvent déposer sur le sol des patines indésirables, doivent être évités. Il est vivement déconseillé d’utiliser des cires, des savons oléagineux, des imprégnants et des traitements variés (hydrofuges et oléofuges) sur le produit Supergres, dont l’application n’est pas nécessaire. En présence desdits traitements, il faut tout d’abord les faire disparaître du sol en utilisant des produits spécifiques, en suivant les instructions reportées par le fabricant.

En cas de patines créées par du savon, du calcaire ou de la saleté, il faut au contraire utiliser un détergent acide, dilué de manière adaptée dans de l’eau (respecter les instructions indiquées sur l’étiquette du produit).

Il convient de signaler que l’acide fluorhydrique (HF) et ses dérivés peuvent endommager irrémédiablement les carreaux.

Pour le nettoyage ordinaire, Supergres conseille l’utilisation d’eau de Javel ou d’ammoniaque, diluées de manière adaptée dans de l’eau.

Toutes les surfaces lustrées ou polies ont besoin d’être nettoyées avec des outils non abrasifs afin d’éviter les opacifications et les rayures.

En outre, le séchage du sol est conseillé afin d’éviter la formation d’auréoles.

Nettoyage supplémentaire

Dans le cas de taches particulières et/ou particulièrement tenaces, il est conseillé d’utiliser des détergents spécifiques, comme indiqué dans le Tableau 1 : "produits pour le nettoyage ". En outre, il ne faut pas oublier que l’élimination de toute tache est plus simple lorsque celle-ci est encore fraîche. Il est important de toujours faire un test préalable avant l’utilisation des produits détergents, notamment sur grès cérame lustré ou poli.

Tableau 1 - Produits pour le nettoyage

TYPE DE SALETE	SOLUTION	DETERGENTS / FABRICANTS
CALCAIRE, CHARBON, CIMENT, PLÂTRE, MORTIER, CRAYON, RÉSIDU MÉTALLIQUE, ROUILLE, CIMENT-JOINT, MORTIER COLORÉ, DÉTEMPRES MURALES	SOLUTION ACIDE	<p> DETERDEK PRO / FILA</p> <p> SOLVACID / GEAL</p> <p> CEMENT REMOVER / FABER</p> <p> KERANET / MAPEI</p> <p> DELTA PLUS ECO / KERAKOLL</p>
BIÈRE, CAFÉ, COCA COLA, VIN, GLACE, PNEU, GRASSES, KETCHUP, MAYONNAISE, CONFITU-RE, MOUTARDE, ROUGE À LÈVRE, HUILE DE LIN, TEINTURE POUR CHEVEUX, URINE, VOMI,	SOLUTION ALCALINE	<p> PS87 PRO / FILA</p> <p> DETERFLASH / GEAL</p> <p> TILE CLEANER / FABER</p> <p> AMMONIACA / UNIVERSALE</p>
AURÉOLE DE VENTOUSES, GOUDRON, CIRE DE BOUGIE, CIRE PROTECTRICE, COLLE, CHEWING-GUM, ENCRE, RUBAN ADHÉSIF, HUILES, FEUTRE, RÉSINES, VERNIS À ONGLES, CIGARETTE	SOLVANT	<p> FILA SOLV / FILA</p> <p> ALKALIN CLEANER / FABER</p> <p> ACETONE / UNIVERSALE</p> <p> TRIELINA / UNIVERSALE</p>

Pour toute question spécifique, contactez:

FILA (www.filasolutions.com), **KERAKOLL** (www.kerakoll.com), **MAPEI** (www.mapei.it), **GEAL** (www.geal-chim.it), **FABER** (www.faberchimica.com)

Verlegung vor Ort

Nach Erhalt des Materials und nach Prüfung der Übereinstimmung der Lieferpapiere mit der Ware, auf jeden Fall aber vor der Verlegung, muss sorgfältig geprüft werden, ob Farbton und Werkmaß übereinstimmen und es sich um das bestellte Material (Sortierung) handelt. Es muss auch überprüft werden, dass das Material frei von offensichtlichen Mängeln ist (wie in den allgemeinen Geschäftsbedingungen und in Tabelle 2 - Seite 366), da keine Ansprüche auf bereits verlegtes Material geltend gemacht werden können, dessen Mängel vor der Verlegung bereits sichtbar waren.

Da Farbabweichungen ein Merkmal von keramischen Produkten sind, ist eine Überprüfung des V- SHADE-Wertes der zu verlegenden Fliesen erforderlich. Um das bestmögliche ästhetische Ergebnis zu erzielen, verlegen Sie das Material am besten so, dass Fliesen abwechselnd aus mehreren Kisten entnommen werden, um eine optimale Durchmischung zu erzielen.

Bei Produkten mit Aderungen wird, wie bei Naturstein, empfohlen die Aderungen der Platten so anzuordnen, dass die beste ästhetische und farbliche Wirkung erzielt wird.

Der Auftraggeber hat, soweit möglich, für die mikroklimatischen Bedingungen und die entsprechenden Lichtverhältnisse zu sorgen, die es dem Fliesenleger ermöglichen, die Verlegearbeiten zuverlässig durchzuführen und dabei die Materialien und die laufenden Arbeiten, wie zuvor vorgeschrieben, zu kontrollieren.

Es wird empfohlen, spezielle, leistungsstarke Klebstoffe aufzutragen. Denken Sie daran, dass der Untergrund zum Zeitpunkt der Verlegung stabil, trocken und ausgereift sein muss. In jedem Fall müssen die jeweiligen Anweisungen der Hersteller der jeweiligen Untergründe und spezifischen Klebstoffe befolgt werden. Verlegemörtel auf Zementbasis müssen bei Raumtemperatur und in der Regel zwischen +5° C und +30/35° C aufgetragen werden.

Informationen über die am besten geeigneten Klebstoffe für die Verlegung von Fliesen und Platten der Marke Supergres sind der derzeit gültigen europäischen Norm EN12004 zu entnehmen.

Während der Verlegung darf das Material nicht auf der Oberseite mit Bleistiften (Graphit) oder Permanentmarkern gekennzeichnet werden, insbesondere gilt dies für polierte Fliesen und Platten.

Obwohl ein Anfeuchten der Fliesen vor dem Verlegen nicht erforderlich ist, ist es ratsam, wenn die Rückseite der Fliesen sehr staubig ist, sie schnell in sauberem Wasser abzuwaschen.

Während des Zeitraums zwischen Abschluss der Verlegung und der Übergabe an den Auftraggeber müssen die Keramikfliesen sauber und frei von Zement, Sand, Mörtel und jeglichem anderen Material, das Flecken und/oder mechanischen Oberflächenabrieb verursachen kann, gehalten werden. Die verlegten Flächen müssen vor Beschädigungen oder Verunreinigungen geschützt werden, die möglicherweise durch eine vorhersehbare Anwesenheit anderer Handwerker wie Maler, Elektriker, Zimmerleute usw. verursacht werden.

Für die Verbandverlegung empfiehlt es sich, die Fliesen maximal um 20 cm zu versetzen. Für geschliffene Fliesen und Platten wird eine Fugenbreite von mindestens 2 mm vorgeschrieben (diese Art der Verlegung ermöglicht eine bessere Haftung des Fugenmörtels an den Seiten der Platten, eine bessere Aufnahme von Bewegungen des Untergrundes und eine Kompensation der Platten). Für nicht geschliffene Fliesen und Platten wird eine Fugenbreite von mindestens 5 mm vorgeschrieben.

Supergres akzeptiert keine Reklamationen, wenn geschliffene Fliesen und Platten mit einer Fugenbreite von weniger als 2 mm verlegt werden.

Beim Schneiden von Fliesen kann sich Siliziumdioxidstaub bilden (SiO₂); wir empfehlen die Verwendung von Handschneidern in einer offenen Umgebung oder vorzugsweise Nassmaschinen. Auf der Baustelle ist es wichtig, die Atemwege mit einer Maske, die Augen mit einer Schutzbrille und die Hände mit Arbeitshandschuhen zu schützen. Bei der manuellen Handhabung von Fliesen vorher das Gewicht der Fliesen prüfen, um eine übermäßige Belastung zu vermeiden. Die manuelle Handhabung von Lasten muss in Übereinstimmung mit den geltenden nationalen Vorschriften erfolgen. Auf der Baustelle ist es äußerst wichtig, alle Arten von Abfällen zu trennen, damit sie angeliefert und, wenn möglich, wiederverwertet werden können. Wir empfehlen, die beim Abriss von Boden- und Wandverkleidungen anfallenden Materialien ökologischen Sammelstellen zuzuführen, um eine umweltgerechte Entsorgung zu gewährleisten.

HINWEIS:

SUPERGRES AUF SCHON VERLEGTEM FLIESEN UND PLATTEN:

- **SUPERGRES AKZEPTIERT KEINE BEANSTANDUNGEN AUFGRUND OFFENSICHTLICHER MÄNGEL, WIE IN TABELLE 2 - SEITE 366.**

- **SUPERGRES IST NICHT FÜR DIE QUALITÄT DER FLIESENARBEITEN VERANTWORTLICH, SONDERN NUR FÜR DIE EIGENSCHAFTEN DES DELIEFERTEN MATERIALS.**

ES IST RATSAM, EINIGE ERSATZFLIESEN AM ENDE DER INSTALLATION FÜR EVENTUELLE REPARATUREN AUFZUBEWAHREN ODER IM FALLE EINER REKLAMATION AUF DIESE WEISE EIN REPRÄSENTATIVES MUSTER DES MATERIALS ZUR HAND ZU HABEN.

Fugen und Verfugung

Bei großen Räumen ist es unbedingt notwendig, in regelmäßigen Abständen Dehnungsfugen vorzusehen, während es in kleinen Räumen ausreicht, einen kleinen Abstand zwischen dem verfliesen Bereich und den Außenwänden zu lassen, der von der Sockelleiste verborgen werden wird. In jedem Fall ist es notwendig, dass der Planer oder Bauleiter die Arbeiten beaufsichtigt und überprüft, ob die Verlegung den in den einzelnen Ländern geltenden Vorschriften entspricht.

Bei der Verwendung von Epoxidharzmörteln oder -fugenmassen mit Zusatz von Harzen oder ähnlichen Materialien ist es ratsam, die Anweisungen des Herstellers sorgfältig zu befolgen, da deren schnelle Aushärtung mehr Aufmerksamkeit erfordert. Wir halten es auch für wichtig, das Reinigungsmittel vor der Anwendung auf dem gesamten Boden zunächst auf einem Teil des Bodenbelags zu testen.

Speziell für geläppte und polierte Produkte empfehlen wir die Verwendung von Fugenmörtel in einer zur Fliese passenden Farbe (z. B. weiße Fliesen mit schwarzer Fugenmasse vermeiden).

Nach dem Verfugen der Feinsteinzeugfliesen ist es wichtig, solange die Fugenmasse noch feucht ist, sofort sorgfältig mit einem Schwamm die überschüssige Fugenmasse zu entfernen.

Es ist jedoch unerlässlich, den Untergrund einige Tage nach der Verlegung, wenn die Fugen getrocknet sind, einer Grundreinigung mit gepufferten Säuren zu unterziehen (siehe folgendes Kapitel: Reinigung „nach der Verlegung“), um alle Baustellenreste vollständig zu entfernen.

Beispiele für spezifische „saure“ Reinigungsmittel (Reinigungsmittel auf Säurebasis) für die Grundreinigung nach der Verlegung sind

- **DETERDEK PRO FILA INDUSTRIA CHIMICA** - www.filachim.com
- **DELTA PLUS ECO KERAKOLL** - www.kerakoll.com
- **KERANET MAPEI** - www.mapei.it
- **SOLVACID GEAL** - www.geal-chim.it
- **DISYCOTT FABER** - www.faberchimica.com

Außergewöhnliche Reinigung „nach der Verlegung“

Feinsteinzeug

Die Grundreinigung „nach der Verlegung“ ist nach Abschluss der Arbeiten zwingend erforderlich.

Die unsachgemäße oder verspätete Entfernung der zum Verfugen verwendeten Fugenmasse kann zu Schmutzrändern führen, die später schwierig zu entfernen sind und auf dem Bodenbelag einen Zementschleier hinterlassen, der alle Arten von Schmutz hartnäckig

festhalten kann.

Es ist unerlässlich, diese Rückstände mit Hilfe von wasserverdünnten, gepufferten Säuren aufzulösen und vollständig zu beseitigen (beachten Sie die Hinweise auf der Verpackung der verwendeten Produkte, die Rückstände müssen innerhalb kurzer Zeit sorgfältig durch das Nachspülen mit reichlich Wasser vom gesamten Bodenbelag vollständig entfernt werden).

Das Waschen und Nachspülen sollte solange wiederholt werden, bis alle Schmutzränder oder Rückstände vollständig entfernt wurden.

Wir empfehlen eine vorherige Testreinigung an einer kleinen Fläche von nur wenigen Quadratmetern durchzuführen. Im Falle eines positiven Ergebnisses kann dann die Reinigung der Gesamfläche erfolgen.

Sobald die Reinigung wie oben beschrieben erfolgt ist, muss eine Reinigung mit alkalischen Reinigungsmitteln erfolgen, dabei sind fettlösende Mittel zu verwenden. Dies ist notwendig, da säurehaltige Reiniger fettige Schlieren auf dem Boden zurücklassen könnten, die dazu beitragen könnten, Schmutz festzuhalten.

Vor der Verwendung dieser Produkte die Etiketten auf der Verpackung sorgfältig durchlesen, um eine sichere und wirksame Anwendung zu gewährleisten.

Weißschrubige Wandfliesen

Die Reinigung nach der Verlegung ist von grundlegender Bedeutung für alle nachfolgenden Reinigungs- und Pflegearbeiten: Durch diesen Eingriff werden Verlegerückstände und normaler BaustellenSchmutz wie Mörtel, Klebstoffe, Farbe usw. beseitigt. Sobald die Fugenmasse getrocknet ist, muss eine Grundreinigung mit einem neutralen Reinigungsmittel erfolgen, dabei sind die Anweisungen des Herstellers sorgfältig zu befolgen.

Dekore und spezielle Einsätze mit Materialapplikationen und/oder Edelmetallen (Gold - Silber)

Sowohl bei der Reinigung als auch bei der Verlegung ist Vorsicht geboten. Vermeiden Sie unbedingt die Verwendung von scheuernden Reinigungsmitteln oder Werkzeugen, die Kratzer und Beschädigungen der Oberfläche verursachen können. Zur Reinigung empfiehlt Supergres, nur weiche Tücher mit heißem Wasser und Alkohol zu verwenden.

Tägliche Reinigung und Pflege

Nach der Reinigung „nach der Verlegung“ (voriges Kapitel) wird für die tägliche Reinigung die Verwendung eines neutralen Reinigungsmittels empfohlen.

Gewerbliche Reinigungsmittel mit Wachsen und Polierzusätzen, die unerwünschte Beschichtungen auf dem Boden hinterlassen können, sollten vermieden werden. Wir raten von der Verwendung von Wachsen, öligen Seifen, Imprägniermitteln und sonstigen Behandlungen (zur Erzielung von wasser- und ölabweisenden Eigenschaften) auf dem Supergres-Produkt ab, eine solche Behandlung ist nicht erforderlich. Sollten solche Behandlungen bereits erfolgt sein, müssen diese mit speziellen Produkten und unter Beachtung der Anweisungen des Herstellers vom Boden entfernt werden.

Hat sich eine Patina aus Seife, Kalkstein und Schmutz gebildet, muss stattdessen ein saures, in Wasser verdünntes Reinigungsmittel verwendet werden (Hinweise auf dem Produktetikett beachten).

Es ist zu beachten, dass Flusssäure (Fluorwasserstoffsäure) (HF) und Derivate die Fliesen irreparabel beschädigen können.

Für die normale Reinigung empfiehlt Supergres die Verwendung von Chlorbleiche oder Ammoniak, das mit Wasser verdünnt wird. Alle geläppte oder polierte Oberflächen erfordern den Einsatz von nicht abrasiven Werkzeugen während der Reinigung, um den Verlust des Glanzes und Kratzer zu vermeiden.

Der Boden sollte nach der Reinigung getrocknet werden, um die Bildung von Schlieren zu vermeiden.

Besondere Reinigung

Bei besonderen oder besonders hartnäckigen Verschmutzungen sollten spezielle Reinigungsmittel verwendet werden, wie in der Tabelle 1 angegeben. Reinigungsprodukte. Außerdem darf nicht vergessen werden, dass sich Flecken einfacher entfernen lassen, wenn sie noch frisch sind.

Vor der Verwendung von Reinigungsmitteln, insbesondere bei geläppter oder poliertem Feinsteinzeug, muss immer vorher ein Test durchgeführt werden.

Tabelle 1 - Reinigungsprodukte

ART DER VERSCHMUTZUNG	LÖSUNG	REINIGUNGSMITTEL / HERSTELLER
KALKAUSBLÜHUNGEN, KOHLE, ZEMENT, GIPS, MÖRTEL, BLEISTIFT, METALLRESTE, ROST, ZEMENTMÖRTEL, FARBIGER FUGENMASSE, WANDFARBE,	SAUREHALTIG	DETERDEK PRO / FILA SOLVACID / GEAL CEMENT REMOVER / FABER KERANET / MAPEI DELTA PLUS ECO / KERAKOLL
BIER, KAFFEE, COCA COLA, WEIN, EISCREME, GUMMI, TIERISCHE FETTE, KETCHUP, MAYONNAISE, STAU, SENF, LIPPENSTIFT, LEINOL, HAARFÄRBE MITTEL, URIN, ERBROCHENES	ALKALISCHE LÖSUNG	PS87 PRO / FILA DETERFLASH / GEAL TILE CLEANER / FABER AMMONIACA / UNIVERSALE
RÄNDER VON SAUGNÄPFEN, TEER, KERZENWACHS SCHUTZWACHS, KLEBER, KAUGUMMI, TINTE KLEBE BAND, ÖL, STIFTE, HARZ, NAGELACK, ZIGARETTEN	LÖSUNGSMITTEL	FILA SOLV / FILA ALKALIN CLEANER / FABER ACETONE / UNIVERSALE TRIELINA / UNIVERSALE

ATTENZIONE

• Le pavimentazioni da esterno posate a secco in quota sono soggette **all'azione del vento, con il rischio di sollevamento delle lastre**. Il produttore raccomanda di far verificare l'idoneità del sistema di posa in quota da un tecnico abilitato in base alla normativa locale vigente ed alle condizioni d'uso, al fine di evitare **il rischio di danni a persone e cose**.

• Una lastra ceramica posata su un sistema sopraelevato **può rompersi per impatto qualora un oggetto pesante cada sulla stessa** da una certa altezza, con il rischio di seri danni per chiunque possa sostare o transitare sulla piastrella stessa. Il mancato rispetto delle istruzioni fornite dal produttore relative alla posa su sistemi sopraelevati può provocare seri **danni alla persona**.

• Per maggiori informazioni e raccomandazioni di posa si rimanda al nostro sito www.supergres.com

ISTRUZIONI PER COMMITTENTI E PROGETTISTI

Quando l'applicazione delle lastre in 20 mm prevede l'utilizzo del **prodotto ceramico in termini strutturali**, si raccomanda al progettista e/o committente una attenta valutazione dei requisiti del progetto in relazione alle caratteristiche tecniche delle lastre. In particolare, al fine di evitare il **rischio di danni a persone o cose** il produttore raccomanda:

• se l'applicazione prevede la posa sopraelevata, tenendo conto che una piastrella potrebbe rompersi in seguito alla caduta su di essa di un corpo pesante, verificare anticipatamente la destinazione d'uso specifica e attenersi alla **tabella istruzioni di posa sopraelevata di seguito riportata (pag. 350)** ove, in determinate condizioni, è prevista l'applicazione di un rinforzo sul retro della piastrella (doppia rete di fibra di vetro) fornito dal produttore;

• con riferimento alla pavimentazione posata in quota, con qualunque sistema di posa a secco, rispettare le specifiche normative e condizioni d'uso locali riguardanti, tra l'altro, a titolo esemplificativo, **l'azione del vento, il carico strutturale, le azioni sismiche**, ecc.;

Il mancato rispetto delle raccomandazioni soprariportate possono portare ad un utilizzo improprio del prodotto e causare eventualmente gravi danni a persone o cose.

INSTRUCTIONS AND RECOMMENDATIONS FOR THE INSTALLATION OF T20 FLOORS

WARNING

• Outdoor pavings installed unglued above the ground level **are subject to the action of the wind, with the risk**, in some cases, **of becoming airborne**. The manufacturer recommends to require the assistance of a qualified professional in order to check the suitability of the installation system above the ground adopted, in accordance with the local laws and regulations and the conditions of use. Failure to do so could result in **serious injury** or property damage.

• A ceramic slab installed on a raised pedestal system **may fracture on impact if a heavy object is dropped onto it** from a height, with a risk of injury to anyone standing or walking on such slab. Failure to adhere to the manufacturer's instructions for installation of slabs on raised pedestal systems may result in serious injury.

• For further information and recommendations concerning the installation systems please refer to www.supergres.com

INSTRUCTIONS FOR PROJECT ENGINEERS AND CUSTOMERS

If the application of the 20 mm slabs foresees the **ceramic product used in structural installations**, the project engineer and/or customer must carefully assess the project requirements with regard to the technical specifications of the slabs. To prevent the risk of damage or injury, the manufacturer recommends:

• With regard to a raised floor installation a ceramic slab may fracture on impact if a heavy object falls on it from any significant height. Therefore the manufacturer recommends to check the specific intended use before starting the installation and **to follow table for raised installation provided below (page 350)**. In certain conditions, reinforcing must be applied on the back of the slabs (double fiberglass) supplied and applied by the manufacturer;

• With reference to any dry installation system of flooring above the ground level, the manufacturer recommends to comply with local regulations and conditions of use with regard **to wind-load, loadbearing, seismic events**, etc.

Failure to comply with these recommendations may lead to improper use of the product and could cause **serious damage or injury**.

AVERTISSEMENT

• Les dallages extérieurs posés sans collage sont soumis à **l'action du vent, avec le risque de soulèvement des plaques**, notamment ceux posés aux étages d'un bâtiment. Le fabricant recommande de faire vérifier par un technicien qualifié la bonne adaptation du système de pose en étages avec la réglementation en vigueur et les conditions d'utilisation locales, afin d'éviter le risque **de dommages aux personnes et aux biens**.

• Une dalle céramique posée sur un système surélevé **peut se casser à la suite d'un impact d'un objet lourd** qui y chuterait d'une certaine hauteur, avec le risque de sérieux dommages pour quiconque stationnerait ou transiterait sur ce carreau. Le non respect des instructions fournies par le fabricant relatives à la pose sur des systèmes surélevés peut provoquer de **sérieux dommages aux personnes**.

• Pour toutes informations complémentaires et recommandations de pose, veuillez vous référer à notre site www.supergres.com

INDICATIONS ET AVERTISSEMENTS POUR CONCEPTEURS ET MAITRES D' OEUVRE

Lorsque la mise en œuvre de dalles de 20 mm prévoit l'utilisation du **produit céramique en termes structurels**, il est recommandé aux concepteurs, maîtres d'œuvre et/ou aux maîtres d'ouvrage de faire une évaluation scrupuleuse du cahier des charges du projet eu égard aux caractéristiques techniques des dalles. En particulier, afin d'éviter le risque de dommages aux personnes ou aux biens, le fabricant recommande :

• Si la mise en œuvre prévoit une pose surélevée, en tenant compte qu'un carreau pourrait se casser suite à la chute d'un corps lourd, devérifier en avance la destination d'usage spécifique et de se conformer au **tableau d'instructions de pose surélevée reproduit à la page 350**, où, dans des conditions déterminées, il est prévu de rajouter un renforcement sur le revers du carreau (un treillis double en fibre de verre) fourni par le fabricant.

• Concernant le dallage posé en étages, quelque soit le système de pose sans collage utilisé, de respecter les spécifications des normes et les conditions locales d'emploi, entre autre, à titre d'exemple, **l'action du vent, le chargement structurel, les actions sismiques**, etc.

Le non respect des recommandations reproduites ci-dessus peut conduire à un usage improprie du produit et éventuellement causer de graves dommages aux personnes ou aux biens.

HINWEISE UND TIPPS FÜR DIE VERLEGUNG VON T20

WARNUNG

• Bodenbeläge die trocken im Aussenbereich in der Höhe verlegt werden, unterliegen **der Wirkung des Windes**, wodurch die Gefahr besteht, **dass die Platten aufgeworfen werden**. Der Hersteller erteilt daher die Empfehlung, dass die Eignung des Systems für eine Verlegung in der Höhe durch einen zugelassenen Sachverständigen überprüft wird, wobei die lokal gültigen Vorschriften und Nutzungsbedingungen zu beachten sind, um die **Gefahr von Personen-** und Sachschäden zu vermeiden.

• Eine Keramikplatte die auf einem Doppelbodensystem verlegt ist, **kann durch den Aufprall eines aus einer bestimmten Höhe** herabfallenden Gegenstandes zerbrechen. Hier besteht das Risiko schwerer Verletzungen für all jene die auf der Fliese gehen, oder stehen. Bei Nichtberücksichtigung der vom Hersteller vorgegebenen Verlegevorschriften für Doppelbodensysteme, kann es zu schwerwiegenden **Verletzungen der Personen** kommen.

• Für genauere Informationen und Verlegehinweise verweisen wir auf unsere Webseite www.supergres.com

HINWEISE FÜR PLANER UND AUFTRAGGEBER

Falls der Einsatz der 20 mm Platten eine Verwendung des **keramischen Produkts als Bestandteil der Gebäudestruktur vorsieht**, ist der Planer und/oder der Auftraggeber angehalten, eine sorgfältige Prüfung der Voraussetzungen des Projekts in Bezug auf die technischen Eigenschaften der Platten vorzunehmen. Insbesondere zur **Vermeidung der Gefahr von Personen- und Sachschäden**, erteilt der Hersteller folgenden Hinweis:

• unter Berücksichtigung des Umstandes, dass die Fliese infolge eines schweren herabfallenden Gegenstandes zerbrechen könnte, muss im Falle einer Anwendung als Doppelboden im voraus eine Prüfung des spezifischen Einsatzbereiches erfolgen. Ausserdem ist die nachfolgende **Tabelle mit Verlegeanweisungen zu berücksichtigen (Seite 350)**, die unter bestimmten Bedingungen die Aufbringung einer Verstärkung auf der Rückseite der Fliese vorsieht (Doppelglasfasernetz welche vom Produzenten geliefert wird);

• mit Bezug auf Bodenbeläge die trocken im Aussenbereich in der Höhe verlegt werden, sind die spezifischen lokalen Vorschriften und Nutzungsbedingungen zu berücksichtigen, die unter anderem, wie zum Beispiel für **die Wirkung des Windes, der strukturellen Belastung, der Wirkung von Erdbeben**, etc., vorgesehen sind;

Die Nichtberücksichtigung der oben genannten Anweisungen kann zu einer unsachgemässen Verwendung des Produkts führen und eventuell schwerwiegende Personen- und Sachschäden verursachen.

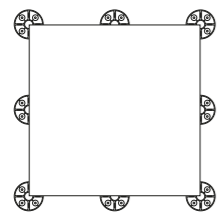
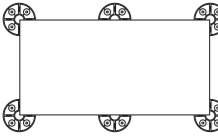
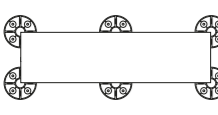
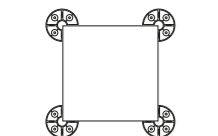
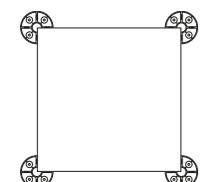
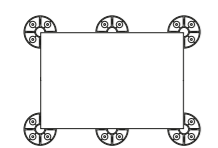
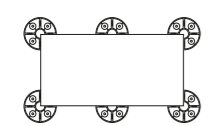
T20 FORMATO SIZE	ALTEZZA FINO A 2 CM UP TO 2 CM	ALTEZZA DA 2 A 10 CM* FROM 2 TO 10 CM	ALTEZZA DA 10 A 30 CM* FROM 10 TO 30 CM
120x120 RT 48"x48" 	8 PIEDI (2,7 pz/m ²) 8 SUPPORTS (2,7 pz/m ²)	8 PIEDI + DOPPIA RETE DI FIBRA DI VETRO (2,7 pz/m ²) 8 SUPPORTS + DOUBLE FIBERGLASS MESH (2,7 pz/m ²) OPPURE SISTEMA T20 UP SENZA RINFORZO (VEDI PAG. 352) / T20 UP SYSTEM WITHOUT REINFORCEMENT (SEE PAGE 352)	8 PIEDI + DOPPIA RETE DI FIBRA DI VETRO (2,7 pz/m ²) 8 SUPPORTS + DOUBLE FIBERGLASS MESH (2,7 pz/m ²) OPPURE SISTEMA T20 UP SENZA RINFORZO (VEDI PAG. 352) / T20 UP SYSTEM WITHOUT REINFORCEMENT (SEE PAGE 352)
60x120 RT 24"x48" 	6 PIEDI (3,4 pz/m ²) 6 SUPPORTS (3,4 pz/m ²)	6 PIEDI + DOPPIA RETE DI FIBRA DI VETRO (3,4 pz/m ²) 6 SUPPORTS + DOUBLE FIBERGLASS MESH (3,4 pz/m ²) OPPURE SISTEMA T20 UP SENZA RINFORZO (VEDI PAG. 352) / T20 UP SYSTEM WITHOUT REINFORCEMENT (SEE PAGE 352)	6 PIEDI + DOPPIA RETE DI FIBRA DI VETRO (3,4 pz/m ²) 6 SUPPORTS + DOUBLE FIBERGLASS MESH (3,4 pz/m ²) OPPURE SISTEMA T20 UP SENZA RINFORZO (VEDI PAG. 352) / T20 UP SYSTEM WITHOUT REINFORCEMENT (SEE PAGE 352)
30x120 RT 12"x48" 	6 PIEDI (7 pz/m ²) 6 SUPPORTS (7 pz/m ²)	6 PIEDI + DOPPIA RETE DI FIBRA DI VETRO (7 pz/m ²) 6 SUPPORTS + DOUBLE FIBERGLASS MESH (7 pz/m ²) OPPURE SISTEMA T20 UP SENZA RINFORZO (VEDI PAG. 352) / T20 UP SYSTEM WITHOUT REINFORCEMENT (SEE PAGE 352)	6 PIEDI + DOPPIA RETE DI FIBRA DI VETRO (7 pz/m ²) 6 SUPPORTS + DOUBLE FIBERGLASS MESH (7 pz/m ²) OPPURE SISTEMA T20 UP SENZA RINFORZO (VEDI PAG. 352) / T20 UP SYSTEM WITHOUT REINFORCEMENT (SEE PAGE 352)
60x60 RT 24"x24" 	4 PIEDI (3,4 pz/m ²) 4 SUPPORTS (3,4 pz/m ²)	4 PIEDI (3,4 pz/m ²) 4 SUPPORTS (3,4 pz/m ²) OPPURE SISTEMA T20 UP SENZA RINFORZO (VEDI PAG. 352) / T20 UP SYSTEM WITHOUT REINFORCEMENT (SEE PAGE 352)	4 PIEDI + DOPPIA RETE DI FIBRA DI VETRO (3,4 pz/m ²) 4 SUPPORTS + DOUBLE FIBERGLASS MESH (3,4 pz/m ²) OPPURE SISTEMA T20 UP SENZA RINFORZO (VEDI PAG. 352) / T20 UP SYSTEM WITHOUT REINFORCEMENT (SEE PAGE 352)
80x80 RT 32"x32" 	4 PIEDI (2 pz/m ²) 4 SUPPORTS (2 pz/m ²)	4 PIEDI (2 pz/m ²) 4 SUPPORTS (2 pz/m ²) OPPURE SISTEMA T20 UP SENZA RINFORZO (VEDI PAG. 352) / T20 UP SYSTEM WITHOUT REINFORCEMENT (SEE PAGE 352)	4 PIEDI + DOPPIA RETE DI FIBRA DI VETRO (2 pz/m ²) 4 SUPPORTS + DOUBLE FIBERGLASS MESH (2 pz/m ²) OPPURE SISTEMA T20 UP SENZA RINFORZO (VEDI PAG. 352) / T20 UP SYSTEM WITHOUT REINFORCEMENT (SEE PAGE 352)
60x90 RT 24"x36" 	6 PIEDI (4,8 pz/m ²) 6 SUPPORTS (4,8 pz/m ²)	6 PIEDI + DOPPIA RETE DI FIBRA DI VETRO (4,8 pz/m ²) 6 SUPPORTS + DOUBLE FIBERGLASS MESH (4,8 pz/m ²) OPPURE SISTEMA T20 UP SENZA RINFORZO (VEDI PAG. 352) / T20 UP SYSTEM WITHOUT REINFORCEMENT (SEE PAGE 352)	6 PIEDI + DOPPIA RETE DI FIBRA DI VETRO (4,8 pz/m ²) 6 SUPPORTS + DOUBLE FIBERGLASS MESH (4,8 pz/m ²) OPPURE SISTEMA T20 UP SENZA RINFORZO (VEDI PAG. 352) / T20 UP SYSTEM WITHOUT REINFORCEMENT (SEE PAGE 352)
45x90 RT 18"x36" 	6 PIEDI (6 pz/m ²) 6 SUPPORTS (6 pz/m ²)	6 PIEDI + DOPPIA RETE DI FIBRA DI VETRO (6 pz/m ²) 6 SUPPORTS + DOUBLE FIBERGLASS MESH (6 pz/m ²) OPPURE SISTEMA T20 UP SENZA RINFORZO (VEDI PAG. 352) / T20 UP SYSTEM WITHOUT REINFORCEMENT (SEE PAGE 352)	6 PIEDI + DOPPIA RETE DI FIBRA DI VETRO (6 pz/m ²) 6 SUPPORTS + DOUBLE FIBERGLASS MESH (6 pz/m ²) OPPURE SISTEMA T20 UP SENZA RINFORZO (VEDI PAG. 352) / T20 UP SYSTEM WITHOUT REINFORCEMENT (SEE PAGE 352)

* **For USA, Australia and Canada:**

CERAMICHE
SUPERGRES

ALL SIZES, 20 MM THICKNESS ARE CONSIDERED SUITABLE FOR LAYING ON SUPPORTS AT A **MAXIMUM HEIGHT OF 2 CM (¾")**.
FOR SPECIAL RAISED APPLICATION, CONTACT SUPERGRES TECHNICAL DEPARTMENT.

Per ulteriori informazioni e per avere informazioni specifiche relative alla doppia fibra di vetro da incollare sul retro della piastrella, vi preghiamo di contattare Supergres. **Ceramiche Supergres é responsabile solo se ha fornito l'intero sistema (piastrella + rinforzo)**. Non può essere ritenuta responsabile per sistemi di rinforzo che non ha fornito. In caso di rottura, la lastra va immediatamente sostituita.

For further information and for technical specifications about the double fiberglass net to be applied on the back of the tile, we kindly ask you to contact the company. **Supergres is responsible only if it supplies the whole system (ceramic tiles + reinforcing system)**. Supergres cannot be held responsible for reinforcing systems that has not supplied. In case of breakage, tile must be replaced immediately.

Pour de plus amples renseignements ou pour obtenir des informations détaillées concernant la double fibre de verre à coller sur la dalle, nous vous invitons à contacter l'entreprise. **Supergres ne peut être tenue responsable que si elle a fourni le système complet (dalle + renfort)**. En cas de rupture, la dalle doit être immédiatement remplacée.

Für weitere Informationen und für spezielle Informationen zu der doppelten Glasfaser die an die Fliese geklebt wird, kontaktieren Sie bitte das Unternehmen. **Supergres kann nur haftbar gemacht werden, wenn das ganze System (Fliese + Verstärkung)** komplett geliefert worden ist. Bei Bruch die Platte bitte sofort austauschen.



Doppia rete - Double fiberglass net

DRENAGGIO DELL'ACQUA

Per ottenere un drenaggio ottimale del piano di calpestio è necessario prevedere le opportune pendenze trasversali e longitudinali da realizzare durante il livellamento o la compattazione. Si ricorda comunque che il gres porcellanato ha un assorbimento d'acqua praticamente nullo, e ciò può comportare ristagni di acqua localizzati principalmente sui bordi delle piastrelle.

DRAINAGE OF WATER

In order to obtain perfect drainage of the foot plan, it is necessary to predispose adequate diagonal and longitudinal inclination during the levelling and compacting phase of installation. We would like to remind you that porcelain stoneware has a poor level of water absorption and this can lead to deposit of water, mainly on tile edges.

DRAINAGE DE L'EAU

Pour obtenir un drainage optimal du plancher, il est nécessaire de prévoir les pentes transversales et longitudinales adéquates qui devront être réalisées lors du nivellement ou du compactage. Nous rappelons toutefois que le grès cérame a une absorption d'eau quasiment nulle, et cela peut comporter des stagnations d'eau principalement localisées sur les bords des carreaux.

ENTWÄSSERUNG

Optimale Entwässerung der Tritfläche zu erreichen ist notwendig bereits beim Nivellieren oder Verdichten für das entsprechenden Längs- und Quergefälle zu sorgen. Es wird darauf hingewiesen, dass Feinsteinzeug praktisch kein Wasser absorbiert was vor allem zu Wasseransammlungen an den Kanten der Fliesen führen kann.

T20 UP – SISTEMA PER PAVIMENTI SOPRAELEVATI IN AMBIENTI ESTERNI
T20 UP – SYSTEM FOR RAISED FLOORS IN OUTDOOR ENVIRONMENTS
T20 UP – SYSTÈME POUR SOLS SURÉLEVÉS DANS DES ESPACES EXTÉRIEURS

T20 UP è un sistema, pratico ed innovativo, che permette di realizzare pose sopraelevate con la massima libertà compositiva. Grazie alla struttura portante in polipropilene, e ai supporti regolabili in altezza, si possono posare a secco i pavimenti in gres porcellanato T20.

A differenza delle tradizionali pose sopraelevate su piedino singolo, T20 Up è un sistema innovativo perché permette di realizzare qualsiasi schema di posa: pose sfalsate o pose modulari di diversi formati. È pratico ed economico perché rende possibile posare diversi formati con la garanzia della massima sicurezza, anche in caso di rottura, senza la necessità di applicare alcun sistema di rinforzo sul retro delle lastre.

T20 UP is a practical, innovative system for raised floors that offers maximum freedom of design, composed of a bearing structure in polypropylene and height-adjustable supports on which T20 porcelain stoneware floors are dry-laid.

Unlike traditional raised laying systems on a single support, T20 UP is an innovative system that can be used with any laying scheme: random or modular with different sizes. It is practical and economical, because it makes it possible to lay different sizes while guaranteeing maximum safety, even in the case of breakage, without the need to apply any reinforcement system on the back of the slabs.

T20 UP est un système, pratique et novateur, qui permet de réaliser des poses surélevées avec une liberté de composition la plus totale, et qui se compose d'une structure porteuse en polypropylène et de supports réglables en hauteur, sur lesquels sont posés à sec les sols en grès cérame T20.

Contrairement aux poses surélevées traditionnelles sur un pied individuel, T20 Up est un système novateur car il permet de réaliser toutes sortes de schémas de pose : poses décalées ou poses modulaires de différents formats. Il est pratique et économique car il rend possible la pose de formats différents tout en garantissant la sécurité maximale, même en cas de rupture, sans l'application d'un système de renfort au dos des plaques.

T20 UP ist ein praktisches und innovatives System, das es ermöglicht, Doppelböden mit maximaler Gestaltungsfreiheit zu installieren. Sie bestehen aus einer tragenden Struktur aus Polypropylen und höhenverstellbaren Stützen, auf denen die T20 Feinsteinzeugböden trocken verlegt werden.

Im Gegensatz zur herkömmlichen Verlegung auf einem einzigen Stützfuß ist T20 Up ein innovatives System, das beliebige Verlegeschemen ermöglicht: versetzte Verlegung oder modulare Verlegung von Fliesen und Platten unterschiedlicher Größe. Das System ist praktisch und kostengünstig, denn es ermöglicht die Verlegung verschiedener Größen mit der Garantie maximaler Sicherheit auch im Falle eines Bruchs, ohne dass auf der Rückseite der Platten ein Bewehrungssystem angebracht werden muss.

COMPONENTI DEL SISTEMA T20 UP / COMPONENTS OF THE SYSTEM T20 UP

MODULO DI POSA Laying module Module de pose Verlegemodul	
BASE SUPPORTO Support for base Base support Basissupport	
REGOLAZIONE ALTEZZA SUPPORTO Support adjuster Régulateur de support Höheneinstellung für Stützen	
SUPPORTO FISSAGGIO Fixing support Support de fixation Befestigungen	
SEPARATORE DI POSA Laying spacers Séparateurs de pose Trennsteg	
TRAVERSI Stringers Traverses Querstreben	

COMPONENTI OPZIONALI / OPTIONAL COMPONENTS

DISTANZIALE PER SOPRAELEVAZIONE Spacers for raised floors Entretroises pour surélévation Abstandshalter für die Überhöhung		25 mm
DISTANZIALE PER SOPRAELEVAZIONE Spacers for raised floors Entretroises pour surélévation Abstandshalter für die Überhöhung		50 mm
TAPPETINO FONO ASSORBENTE Sound-absorbing mat Tapis phono absorbant Textilier Belag zur Schallabsorption		20x20x0.3 cm

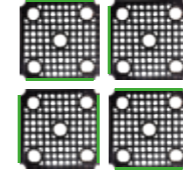
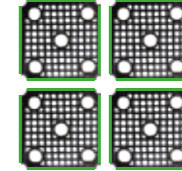
FORMATI . Sizes Formats . Formate	60x60 . 60x120 . 45x90 . 60x90 . 80x80 . 120x120	30x120
NUMERO DI TRAVERSI Number of stringers Nombre de traverses Anzahl der Querstreben	2 TRAVERSI (posa a coppia alternata) 2 STRINGERS (laying in alternate pairs) 2 TRAVERSESES (pose à couples alternés) 2 QUERTRÄGER (abwechselnde Verlegung in Paaren)	4 TRAVERSI (posa completa) 4 STRINGERS (complete laying) 4 TRAVERSESES (pose complète) 4 QUERTRÄGER (vollständige Verlegung)
SCHEMA Scheme Plan Muster		

ATTENZIONE

Le pavimentazioni da esterno posate a secco in quota sono soggette all'azione del vento, con il rischio di sollevamento delle lastre. Il produttore raccomanda di far verificare l'idoneità del sistema di posa in quota da un tecnico abilitato in base alla normativa locale vigente ed alle condizioni d'uso, al fine di evitare il rischio di danni a persone e cose.

Per maggiori informazioni e raccomandazioni di posa si rimanda al nostro sito www.supergres.com
• L'altezza massima consentita per il sistema di posa sopraelevata T20 UP è di 30 cm (12").

WARNING

Dry-laid outdoor paving at altitude is subject to the action of the wind, which risks raising the slabs. The manufacturer recommends that the suitability of the laying system be verified by a qualified technician, based on current local regulations and usage conditions, to avoid the risk of damage to people and objects.

For further information and laying recommendations, see our website www.supergres.com
• The maximum height permitted for the T20 UP raised laying system is 30 cm (12").

ATTENTION

Les sols pour extérieur posés à sec en hauteur sont soumis à l'action du vent et, par conséquent, au risque de soulèvement des plaques. Le fabricant recommande de faire vérifier l'aptitude du système de pose en hauteur par un technicien expert conformément à la norme locale en vigueur et aux conditions d'utilisation afin d'éviter le risque de dommages physiques et matériels.







Pour plus d'informations et de recommandations relatives à la pose, consulter notre site www.supergres.com
• La hauteur maximale autorisée pour le système de pose surélevée T20 UP est de 30 cm (12").

ACHTUNG

Trocken verlegter Bodenbelag in größeren Höhen im Außenbereich unterliegt der Windbelastung. Dabei besteht die Gefahr, dass die Platten abgehoben werden. Der Hersteller empfiehlt, die Eignung des Installationssystems in größeren Höhen von einem qualifizierten Techniker gemäß den geltenden örtlichen Vorschriften und den Einsatzbedingungen überprüfen zu lassen, um Personen- und Sachschäden zu vermeiden.

Weitere Informationen und Verlegeempfehlungen finden Sie auf unserer Website www.supergres.com
• Die maximal zulässige Höhe für die Installation von Doppelböden T20 UP beträgt 30 cm (12").









IMBALLI / PACKAGING

ACCESSORI T_20 ACCESSORIES T_20		Pcs x box
DISCO LIVELLATORE DSH3 - disco livellatore h.3 mm		1
SUPPORTO FISSO FS12 - supporto fisso h.12 mm FS15 - supporto fisso h.15 mm FS20 - supporto fisso h.20 mm		1
SUPPORTO REGOLABILE RS25 - Supporto regolabile h.25/40 mm RS40 - Supporto regolabile h.40/70 mm RS60 - Supporto regolabile h.60/100 mm		1
SUPPORTO AUTOLIVELLANTE AS37 - Supporto autolivellante h.37,5/50 mm AS50 - Supporto autolivellante h.50/75 mm		1
CBVS - CLIP BORDO VERTICALE (superiore)		1
CBVI - CLIP BORDO VERTICALE (inferiore)		1
CLBP - CLIP BORDO PIASTRA		1
CHRG - CHIAVE REGOLAZIONE		1

* **Il supporto è fornito a parte.**
The support is supplied separately.
Le support est fourni séparément.
Die Träger werden separat geliefert.

IMBALLI / PACKAGING

ACCESSORI T_20 UP / ACCESSORIES T_20 UP

	codice/ code		pz/sc pcs/box	kg/sc kg/box	m ² /sc sqm/box	
1	MSUP	MODULO DI POSA Laying module Module de pose Verlegemodul		15	40,2	5,4 (0.36 m ² /pz)
2	TUPS	BASE SUPPORTO Support for base Base support Basissupport		38	9,7	5,4
		REGOLAZIONE ALTEZZA SUPPORTO Support adjuster Régulateur de support Höheneinstellung für Stützen		38		
		SUPPORTO FISSAGGIO Fixing support Support de fixation Befestigungen		38		
		SEPARATORE DI POSA Laying spacers Séparateurs de pose Trennstege		33		
3	TUPT	TRAVERSI Stringers Traverses Querstreben		30	10	5,4 (2 traversi per modulo) 2,7 (4 traversi per modulo)
4	TUP2	DISTANZIALE PER SOPRAELEVAZIONE Spacers for raised floors Entretoises pour surélévation Abstandshalter für die Überhöhung	 25 mm	38	3,2	5,4
5	TUP5	DISTANZIALE PER SOPRAELEVAZIONE Spacers for raised floors Entretoises pour surélévation Abstandshalter für die Überhöhung	 50 mm	38	5,6	5,4
6	UPTT	TAPPETINO FONO ASSORBENTE Sound-absorbing mat Tapis phono absorbant Textiler Belag zur Schallabsorption	 (cm 20x20x0.3h)	80	0,1	11,4

Gli imballi del sistema T20 UP sono stati studiati per semplificarne la logistica in cantiere: il materiale è suddiviso in 6 tipologie di imballi, ordinabili separatamente in base alle diverse esigenze costruttive, e ognuno contiene il materiale necessario per la posa di 5.4 mq di superficie, ad eccezione del tappetino foncoassorbente.

Gli imballi 1 e 2 (modulo di posa e base supporto) sono da utilizzare per il sistema T20 UP con altezza minima 5-7 cm. Gli imballi 4-5 si aggiungono in quantità variabile per eventuali esigenze di pose ad altezze più elevate. Il numero di traversi da utilizzare (imballo 3), varia in base al formato da posare come indicato nella tabella riportata a pag. 353.

The packaging materials of the T20 UP system have been studied in order to simplify logistics on the construction site: the material is divided into six types of packaging, which can be ordered separately based on different construction requirements, and each one contains the material necessary for laying 5.4 square metres of surface, except that the sound-absorbing underlay.

Packaging types 1 and 2 (laying module and support base) are to be used with the T20 UP system with a minimum height of 5-7 cm. Packaging types 4-5 are added in varying quantities for any laying requirements at higher heights. The number of stringers to be used (packaging type 3) varies depending on the size to be laid, as indicated in the table on page 353.

Les emballages du système T20 UP ont été conçus pour en simplifier la logistique dans les chantiers : le matériau est subdivisé en 6 types d'emballages pouvant être commandés séparément en fonction des différentes exigences de construction, chacun desquels contenant le matériau nécessaire pour la pose de 5,4 m² de surface, sauf le tapis phono absorbant.

Les emballages 1 et 2 (module de pose et base support) doivent être utilisés pour le système T20 UP avec une hauteur minimum de 5 à 7 cm. Les emballages 4-5 s'ajoutent, dans une quantité variable, pour d'éventuelles exigences de poses à des hauteurs plus élevées. Le nombre de traverses à utiliser (emballage 3) varie suivant le format à poser, comme indiqué dans le tableau reporté à la page 353.

Die Verpackung des T20 UP-Systems wurde so konzipiert, dass die Logistik vor Ort vereinfacht wird: Das Material ist in 6 Verpackungsarten unterteilt, die je nach baulichen Erfordernissen separat bestellt werden können und jeweils das Material für die Verlegung von 5,4 m² Fläche enthalten.

Die Pakete 1 und 2 (Verlegeschema und Stützbasis) sind für das T20 UP System mit einer Mindesthöhe von 5-7 cm zu verwenden. Die Pakete 4 und 5 können in variablen Mengen für Verlegeanwendungen mit größeren Höhen hinzugefügt werden. Die Anzahl der zu verwendenden Querträger (Paket 3) variiert je nach dem zu verlegenden Format, wie in der Tabelle auf Seite dargestellt ist 353.

PEZZI SPECIALI / SPECIAL TILES

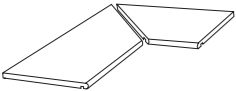
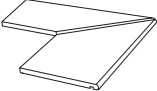
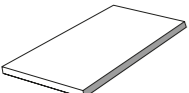
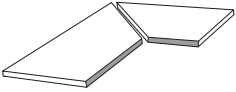
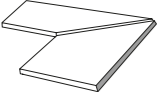
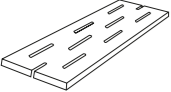
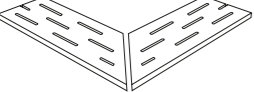
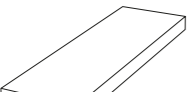
 ROUND	30x60 RT 12"x24"	30x90 RT 12"x36"	40x80 RT 16"x32"	45x90 RT 18"x36"	30x120 RT 12"x48"
 ROUND ANG. INTERNO COMP. / 2 PZ.	30x60 RT 12"x24"	30x90 RT 12"x36"	40x80 RT 16"x32"	45x90 RT 18"x36"	30x120 RT 12"x48"
 ROUND ANG. ESTERNO COMP. / 2 PZ.	30x60 RT 12"x24"	30x90 RT 12"x36"	40x80 RT 16"x32"	45x90 RT 18"x36"	30x120 RT 12"x48"
 COSTA LUCIDA	30x60 RT 12"x24"	30x90 RT 12"x36"	40x80 RT 16"x32"	45x90 RT 18"x36"	30x120 RT 12"x48"
 ANG. INT. COSTA LUCIDA COMP. / 2 PZ.	30x60 RT 12"x24"	30x90 RT 12"x36"	40x80 RT 16"x32"	45x90 RT 18"x36"	30x120 RT 12"x48"
 ANG. EST. COSTA LUCIDA COMP. / 2 PZ.	30x60 RT 12"x24"	30x90 RT 12"x36"	40x80 RT 16"x32"	45x90 RT 18"x36"	30x120 RT 12"x48"
 GRIGLIA	20x60 RT 8"x24"	20x45 RT 8"x18"			
 ANGOLARE GRIGLIA COMP. / 2 PZ.	20x60 RT 8"x24"	20x45 RT 8"x18"			
 TERMINALE "ELLE" C/PROFILO INCOLLATO	20x60 RT 8"x24" (P.20 - L.60 - H. 5)	20x80 RT 8"x32" (P.20 - L.80 - H. 5)	20x90 RT 8"x36" (P.20 - L.90 - H. 5)	22,5x90 RT 9"x36" (P.22,5 - L.90 - H. 5)	20x120 RT 8"x48" (P.20 - L.120 - H. 5)

Tutte le collezioni T_20 sono corredate da un'ampia gamma di pezzi speciali, che permette la finitura a regola d'arte di qualsiasi progetto. Vengono realizzati anche su misura per rispondere a qualsiasi esigenza di posa.

The T_20 collections come complete with a broad range of trims that allow for state-of-the-art finishing of any project. Tailor-made trims are available upon request to meet any installation need.

Toutes les collections T_20 s'accompagnent d'une vaste gamme de pièces spéciales, qui garantit une finition de n'importe quel projet dans les règles de l'art. Elles sont également réalisées sur mesure pour satisfaire toutes les exigences de pose.

Alle T_20 Kollektionen werden von einer breiten Palette von Formteilen ergänzt, um jedes Projekt fachmännisch abzurunden. Diese werden nach Maß gefertigt, um jede Anforderung der Verlegung zu erfüllen.

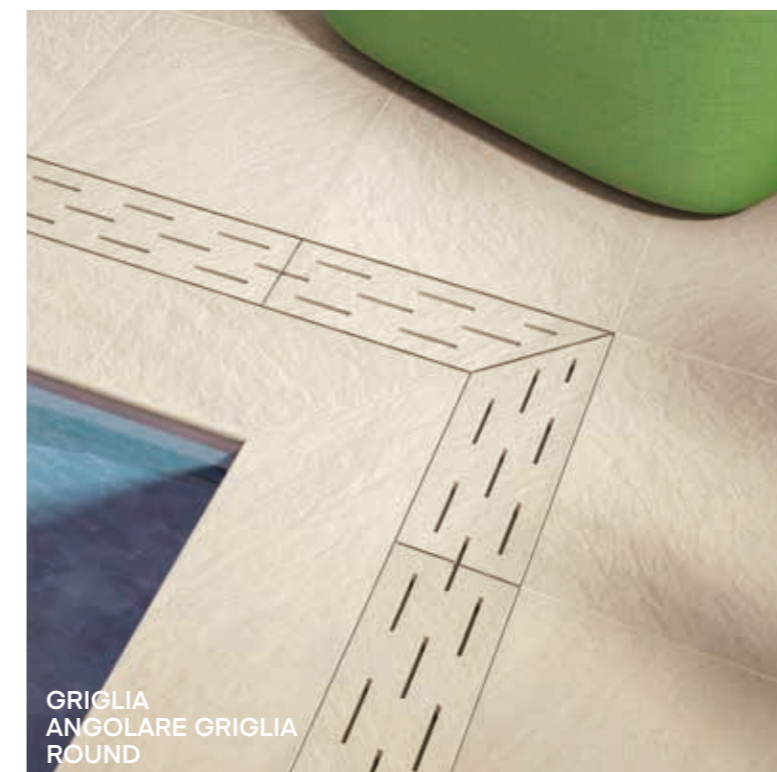

CONDIZIONI GENERALI DI VENDITA

Rev.1a del 1 Gennaio 2018

CERAMICHE
SUPERGRES

A.- MODALITA' DI CONCLUSIONE DEL CONTRATTO

A.1.- Le presenti Condizioni Generali di Vendita disciplinano ogni contratto di Vendita tra il Venditore e l'Acquirente ed ogni loro modifica o deroga deve essere concordata per iscritto.

A.2.- Eventuali offerte, accrediti e/o abbuoni accordati da agenti o da altri intermediari, non sono ritenuti validi se non confermati per iscritto dal Venditore.

A.3.- L'Acquirente invia al Venditore, direttamente o per il tramite di agenti, Ordini scritti che devono contenere l'indicazione dei codici dei Prodotti richiesti, delle quantità, del loro prezzo e della destinazione. L'Ordine inviato dall'Acquirente è irrevocabile.

A.4.- La Vendita dovrà ritenersi conclusa nel momento in cui: (i) l'Acquirente riceva da parte del Venditore una Conferma scritta via e-mail, fax o altri mezzi telematici, conforme ai termini e alle condizioni dell'Ordine; o (ii) in caso di Conferma inviata dal Venditore contenente condizioni difformi dall'Ordine ricevuto dall'Acquirente quando questi l'accetti per iscritto o comunque non la contesti entro 7 (sette) giorni dalla ricezione; o (iii) in assenza di conferma scritta da parte del Venditore, nel momento in cui i Prodotti saranno consegnati e caricati dall'Acquirente

B.- PREZZI

B.1.- Salvo diversa pattuizione scritta, i prezzi di vendita concordati di volta in volta si intendono al netto per contanti e per consegna franco stabilimento del Venditore indicato nella Conferma d'Ordine.

C.- CARATTERISTICHE DEI PRODOTTI

C.1.- L'Acquirente dichiara di aver preso visione ed attenersi al contenuto della seguente documentazione pubblicata nel sito internet aziendale: 1) Manuale di Posa, Uso, Pulizia e Manutenzione e 2) Schede tecniche.

C.2. Data la intrinseca variabilità del prodotto ceramico, le caratteristiche dei campioni e/o modelli inviati in precedenza dal Venditore all'Acquirente sono da considerarsi indicativi e non vincolanti.

C.3. Salvo specifiche richieste da concordare prima della Conferma d'Ordine, il Venditore non garantisce che l'ordine del singolo articolo venga evaso tutto con un medesimo lotto di produzione.

D.- TERMINI DI CONSEGNA

D.1.- I termini di consegna sono da intendersi indicativi e la proroga di essi non può far maturare all'Acquirente alcun diritto a richiedere indennizzi, ogni eccezione rimossa.

D.2.- Se, trascorsi 10 (dieci) giorni dalla data di avviso di merce pronta, l'Acquirente non ritira il materiale, il Venditore si riserva di stabilire discrezionalmente un nuovo termine di consegna.

E.- RESA E SPEDIZIONE

E.1.- L'eventuale variazione della destinazione dei Prodotti, diversa da quella concordata in Conferma d'Ordine, deve essere comunicata dall'Acquirente per iscritto entro e non oltre il secondo giorno antecedente a quello previsto per il ritiro presso la sede del Venditore. Il Venditore si riserva la facoltà di non accettare la variazione della destinazione dei Prodotti. Nel caso si verifichi che la destinazione effettiva del Prodotto sia stata diversa da quella dichiarata dall'Acquirente, il Venditore si riserva la facoltà di sospendere l'esecuzione delle forniture in corso e/o risolvere i contratti in corso senza che l'Acquirente possa rivendicare risarcimenti diretti e/o indiretti di alcun tipo.

E.2.- Salvo patto contrario, la fornitura della merce si intende Franco Fabbrica (EXW ai sensi degli Incoterms 2010) e ciò anche quando sia convenuto che la spedizione o parte di essa venga curata dal Venditore su mandato dell'Acquirente. In ogni caso i rischi passano all'Acquirente al più tardi con la consegna al primo trasportatore.

E.3.- Ferma restando l'estraneità del Venditore rispetto al contratto di trasporto, il Venditore non potrà essere indicato come "shipper" nella polizza di carico. La comunicazione del peso lordo del container allo spedizioniere, non costituisce alcuna assunzione di responsabilità da parte del Venditore ai fini della Convenzione SOLAS (Safety Of Life At Sea). In nessun caso tale comunicazione potrà essere intesa come VGM (Verified Gross Mass).

E.4.- L'Acquirente s'impegna affinché il mezzo inviato presso i magazzini del Venditore sia idoneo al carico in relazione alla natura dei Prodotti. Nel caso il mezzo che si presenta comporti significative difficoltà per le operazioni di carico, il Venditore si riserva di addebitare una penale pari al 4% del valore dei prodotti a copertura dei maggiori costi logistici. Se il mezzo convenuto non è assolutamente idoneo, il Venditore si riserva la facoltà di negare le operazioni di carico senza che nulla possa essere richiesto dall'Acquirente a titolo di risarcimento per ogni onere diretto e/o indiretto che ne possa derivarne.

E.5.- È compito dell'Acquirente incaricare il vettore di controllare i prodotti prima del carico; eventuali osservazioni in relazione all'integrità degli imballi e della rispondenza delle quantità caricate a quelle indicate sul documento di trasporto,

devono essere sollevate dal vettore al momento del carico. Tali osservazioni devono essere riportate su tutte le copie dei documenti di trasporto, altrimenti i prodotti caricati s'intendono integri e completi. Ne deriva che il Venditore non si assume alcuna responsabilità in relazione a mancanze o danni dei prodotti non segnalati dal vettore.

E.6.- È altresì responsabilità dell'Acquirente incaricare il vettore di verificare le modalità e la stabilità del carico sul mezzo affinché durante il trasporto non si verifichino rotture e affinché siano rispettate tutte le disposizioni di sicurezza riguardanti la circolazione stradale.

F.- PAGAMENTI

F.1.- Qualsiasi obbligazione di pagamento deve essere adempiuta presso la sede legale del Venditore. Eventuali pagamenti ad agenti, rappresentanti o ausiliari di commercio non si intendono effettuati finché le relative somme non pervengono al Venditore.

F.2.- E' fatto divieto all'Acquirente di eseguire il proprio adempimento mediante pagamenti provenienti da paesi diversi dal proprio paese di residenza se trattasi di paesi che non garantiscono un adeguato scambio di informazioni con l'Italia. In caso di violazione di tale divieto, il Venditore ha facoltà di risolvere il contratto per giusta causa senza che l'Acquirente possa vantare il diritto di ottenere alcun risarcimento per l'eventuale danno subito.

F.3.- Eventuali spese di bollo ed incasso effetti e tratte sono a carico dell'Acquirente. In caso di inadempimento, anche solo parziale, dal giorno fissato per il pagamento decorreranno a favore del Venditore gli interessi moratori nella misura prevista dal d.lgs. 09/10/2002 n. 231.

F.4.- Salvo diversi accordi scritti, l'Acquirente si impegna a non compensare alcun credito, comunque insorto, nei confronti del Venditore.

G.- RECLAMI

G.1.- Al ricevimento dei Prodotti, l'Acquirente dovrà sottoporli ad accurato controllo attraverso un esame visivo effettuato conformemente alle indicazioni riportate al punto 7 delle norme UNI EN ISO 10545-2

G.2.- L'installazione e la posa dei Prodotti deve essere effettuata attenendosi scrupolosamente alle raccomandazioni inerenti le attività da svolgere prima e durante la posa in opera indicate nel documento 1) Manuale di Posa, Uso, Pulizia e Manutenzione pubblicato nel sito internet del Venditore e sulla confezione del prodotto e/o all'interno della stessa. Non sono considerati vizi del Prodotto quelli generati da un'errata installazione e dalla mancata/errata manutenzione (difformi dalle indicazioni fornite nel 1) Manuale di Posa, Uso, Pulizia e Manutenzione), da una non idonea destinazione d'uso e/o dalla normale usura nel tempo.

G.3.- Fatti salvi i limiti di accettabilità previsti dalla norma internazionale EN 14411 (ISO 13006), le Parti riconoscono come Vizi Palesi i difetti dei Prodotti riscontrabili già al momento del loro ricevimento tali da rendere il materiale inidoneo all'uso o da diminuirne in modo apprezzabile il valore. Rientrano in tale categoria i difetti come definiti nel documento 1) Manuale di Posa, Uso, Pulizia e Manutenzione pubblicato nel sito internet del Venditore. A titolo esemplificativo e non esaustivo si riconoscono come Vizi Palesi i difetti superficiali, i difetti di decorazione, di lappatura/levigatura, di calibro, di planarità, di ortogonalità-rettilineità, di spessore, le crepe, le sbecature, i fuori tono, i toni mescolati e i Prodotti che presentano problemi da taglio/scaglie.

G.4.- Nel caso l'Acquirente rilevi Vizi Palesi dovrà fare reclamo al Venditore per iscritto, a pena di decadenza, entro 8 (otto) giorni dal ricevimento e tenere a disposizione del Venditore l'intera partita di materiale. Il reclamo dovrà riportare i dati di fatturazione e una precisa descrizione del vizio reclamato corredata, quando possibile, da immagini fotografiche. Qualora il reclamo dovesse risultare infondato, l'Acquirente si rende disponibile a risarcire il Venditore delle spese sostenute per l'eventuale sopralluogo (perizie, viaggi ecc.).

G.5.- I Vizi Occulti dovranno essere notificati al Venditore mediante lettera raccomandata A.R., a pena di decadenza dalla garanzia, entro 8 (otto) giorni dalla data della scoperta del difetto.

G.6.- L'azione dell'Acquirente diretta a fare valere la garanzia per vizi si prescrive comunque nel termine di 12 (dodici) mesi decorrenti dalla consegna dei Prodotti.

H.- GARANZIA PER VIZI

H.1. La garanzia del Venditore si intende limitata ai soli Prodotti di prima scelta e non ai Prodotti di seconda o terza scelta o di partite d'occasione con prezzi o sconti particolari quando debitamente segnalati in nota nella Conferma dell'Ordine.

H.2. Il Venditore non garantisce l'idoneità dei Prodotti ad usi particolari, ma soltanto le caratteristiche tecniche pubblicate nel sito internet nel documento 2) Schede tecniche. L'indicazione d'uso, anche quando presentata dal Venditore in cataloghi e manuali, è da ritenersi puramente indicativa. Sulla base delle caratteristiche tecniche riportate nelle 2) Schede Tecniche è sempre compito del progettista

valutare l'idoneità del Prodotto alle condizioni specifiche di utilizzo in funzione delle sollecitazioni e delle variabili che si possono verificare nell'ambiente di destinazione alterandone le sue caratteristiche, a titolo d'esempio, all'intensità del traffico, alla qualità del traffico (calpestio in presenza di sabbia, di detriti...), alle eventuali condizioni climatiche avverse e a qualsiasi altra aleatorietà a cui può essere esposto il materiale.

H.3.- **Nel caso risulti accertato che il Prodotto manifesti Vizi Palesi, come definiti al sub lett. G n.3, il Venditore provvederà alla sostituzione del Prodotto difettoso con altro avente caratteristiche pari o superiori o nel caso ciò non sia possibile ad una congrua riduzione del prezzo. In alternativa l'Acquirente avrà diritto, previa restituzione dei Prodotti viziati, al rimborso del prezzo pagato, maggiorato del costo del trasporto, con esclusione del risarcimento di ogni altro danno diretto e/o indiretto.**

H.4. **La garanzia del Venditore deve ritenersi esclusa nel caso in cui il Prodotto affetto da Vizi Palesi (in tutto o in parte) sia stato utilizzato e/o comunque trasformato dovendosi ritenere che in tal modo l'Acquirente (o il suo cliente) abbia espresso la volontà di accettarli nello stato in cui si trovano.**

H.5 **Nel caso risulti accertato che il Prodotto manifesti Vizi Occulti, la garanzia del Venditore è limitata alla sostituzione del materiale con altro avente caratteristiche pari o superiori e ove ciò non sia possibile al rimborso del prezzo pagato maggiorato del costo del trasporto.** In ogni caso la garanzia del Venditore per ogni danno diretto e/o indiretto comunque originato dal prodotto difettoso, deve intendersi limitata ad una somma che non potrà superare il doppio del prezzo di vendita applicato dal Venditore in relazione alla sola parte della fornitura difettosa.

H.6.- Nel caso l'Acquirente rivenda il Prodotto a soggetti tutelati dal codice del consumo (d.l. n.206/2005) sarà responsabile delle condizioni praticate se difformi da quelle qui riportate e dovrà accertarsi che i diritti del consumatore siano esercitati nel rispetto dei rimedi e dei termini fissati da tale codice. Nel caso sussistano i presupposti, il diritto di regresso e/o comunque di rivalsa spettanti all'Acquirente verso il Venditore/produttore non potrà eccedere le esenzioni ed i limiti come fissati dal sub lett. G n.1 al sub lett. H n.5.

I. CLAUSOLE SOLVE ET REPETE E RISOLUTIVE

I.1.- Ai sensi dell'art. 1462 del Codice Civile, per nessun motivo, ivi compresi pretesi vizi o difetti del materiale, l'Acquirente potrà sospendere o ritardare il pagamento del materiale ritirato, salva naturalmente la facoltà di ripetere quando possa dimostrare di avere indebitamente pagato.

I.2.- Nel caso di mutamento delle condizioni patrimoniali dell'Acquirente o di mancato pagamento anche parziale di prodotti già forniti, il Venditore può sospendere l'esecuzione delle forniture in corso e/o risolvere i contratti in corso senza che l'Acquirente possa rivendicare risarcimenti diretti e/o indiretti di alcun tipo.

L.- PATTO DI RISERVATO DOMINIO

.L.1.- Fino a quando l'Acquirente non avrà provveduto all'integrale pagamento del prezzo, i Prodotti oggetto della fornitura rimarranno di proprietà del Venditore.

L.2.- Durante il periodo suddetto, l'Acquirente assumerà gli obblighi e le responsabilità del custode, e non potrà alienare, dare in uso, lasciare sequestrare o pignorare tali Prodotti senza dichiarare la proprietà del Venditore e dare immediato avviso a mezzo raccomandata A.R.

M.- FORZA MAGGIORE

M.1.- Ciascuna parte potrà sospendere l'esecuzione dei suoi obblighi contrattuali quando tale esecuzione sia resa impossibile o oggettivamente troppo onerosa da un impedimento imprevedibile indipendente dalla sua volontà, quale ad esempio: sciopero, boicottaggio, serrata, incendio, guerra (dichiarata o non), guerra civile, sommosse e rivoluzioni, requisizioni, embargo, interruzioni di energia, rotture straordinarie di macchinari, ritardi nella consegna di componenti o materie prime.

M.2.- La parte che desidera avvalersi della presente clausola dovrà comunicare immediatamente per iscritto all'altra parte il verificarsi e la cessazione delle circostanze di forza maggiore.

M.3.- Qualora la sospensione dovuta a forza maggiore duri più di 60 (sessanta) giorni, ciascuna parte avrà il diritto di risolvere il presente contratto, previo un preavviso di 10 (dieci) giorni, da comunicarsi alla controparte per iscritto.

N.- OBBLIGO DI RISERVATEZZA

N.1.- L'Acquirente è tenuto ad osservare la più assoluta riservatezza su tutte le notizie di carattere tecnico (quali, in via meramente esemplificativa, disegni, prospetti, documentazioni, formule e corrispondenza) e di carattere commerciale (ivi comprese le condizioni contrattuali, i prezzi d'acquisto, le condizioni di pagamento ...) apprese in esecuzione del presente Contratto.

N.2.- L'obbligo di riservatezza viene assunto per tutta la durata del Contratto, nonché per il periodo successivo alla sua esecuzione.

N.3.- In ogni caso di inosservanza dell'obbligo di riservatezza, la parte inadempiente è tenuta a risarcire all'altra tutti i danni che ne dovessero derivare.

O.- MARCHI E SEGNI DISTINTIVI DEL VENDITORE

O.1.-L'utilizzo dei marchi, dei modelli ornamentali e delle opere d'ingegno in genere, in qualunque forma o modo di espressione (quali a titolo meramente esemplificativo, ma non esaustivo: immagini, foto, disegni, filmati, figure, strutture, etc.) costituenti proprietà intellettuale del Venditore, attraverso qualsiasi mezzo (quali a titolo meramente esemplificativo, ma non esaustivo: stampa, video, radio, internet, social media, piattaforme di messaggistica istantanea o VoIP, etc.) è severamente vietato. Qualsiasi deroga a tale divieto, anche solamente parziale, dovrà essere autorizzata per iscritto, caso per caso, dalla Direzione generale del Venditore.

P.- LINGUA DEL CONTRATTO, LEGGE APPLICABILE, GIURISDIZIONE E COMPETENZA

P.1.- Il Contratto e le presenti condizioni sono redatti in lingua Italiana, la quale prevarrà nel caso di divergenza con la traduzione in altre lingue.

P.2.- La definizione di qualsiasi controversia comunque relativa alle forniture è soggetta alla legge ed alla giurisdizione dello Stato Italiano e la competenza territoriale viene devoluta in via esclusiva al Tribunale di Modena nella cui circoscrizione il Venditore ha la sua sede legale.

GENERAL SALES CONDITIONS

Rev.1a of 1st January 2018

CERAMICHE
SUPERGRES

A.- CONTRACT COMPLETION

A.1.- These general sales conditions govern every sales contract between the Seller and the Buyer and any amendment or exception thereof shall be agreed in writing.

A.2.- Any offers, credits and/or rebates granted by agents or other intermediaries, shall not be considered valid if they are not confirmed in writing by the Seller.

A.3.- The Buyer shall send the written orders to the Seller, directly or through the agents, and the orders shall include the codes of the required products, quantity, price and destination. The order sent by the Buyer is irrevocable.

A.4.- The sale shall be deemed completed when: (i) the Buyer receives a written confirmation from the Seller, via e-mail, fax or other electronic means, that complies with the terms and conditions of the order; or (ii) if the confirmation sent by the Seller contains conditions that differ from the order sent by the Buyer, when the latter accepts it in writing or in any case does not object within 7 (seven) days from reception; or (iii) if the Seller does not provide a written confirmation, when the products are delivered and loaded by the Buyer.

B.- PRICES

B.1.- The prices agreed upon for each individual sale are net prices for cash delivery ex works (the Seller's plant shall be specified in the order confirmation), unless otherwise agreed in writing.

C.- PRODUCT CHARACTERISTICS

C.1.- The Buyer declares to have read and comply with the content of the following documentation published on the corporate website: 1) Laying, use, cleaning and maintenance manual and 2) Technical data sheets.

C.2. Given the intrinsic variability of the ceramic products, the characteristics of the samples, previously sent by the Seller to the Buyer, are purely illustrative and cannot be deemed binding.

C.3. Unless specifically requested and agreed before the order confirmation, the Seller does not guarantee that the entire quantity of an article on order shall be sent from one same production lot.

D.- DELIVERY TERMS

D.1.- The delivery terms are approximate and a delay does not give the Buyer any right to claim compensation, without any exception.

D.2.- If the Buyer does not collect the goods, after 10 (ten) days from the date of the "goods ready" notice, the Seller has the right – at its discretion – to establish a new delivery date.

E.- SHIPPING ARRANGEMENTS AND TERMS

E.1.- The Buyer must communicate any variation in the destination of the products, different from the one agreed in the order confirmation, in writing within, and no later than, the second day before the day foreseen for the collection at the Seller's premises. The Seller reserves the right not to accept the change of the product destination. If the actual destination of the product is different from the one stated by the Buyer, the Seller reserves the right to suspend the execution of the supplies underway and/or to terminate the contracts in force and the Buyer shall not have the right to claim direct and/or indirect compensation of any type.

E.2.- Unless otherwise agreed, the goods shall be delivered ex-works (EXW – Incoterms 2010) and this shall also be the case when the parties agree that the delivery, or part of it, shall be arranged by the Seller on the Buyer's behalf. In any case, the risks shall transfer to the Buyer upon delivery to the first carrier.

E.3.- Without prejudice to the Seller's extraneity in relation to the transport contract, the Seller shall not be indicated as "shipper" on the bill of lading. The communication of the gross weight of the container to the Forwarding agent does not represent in any way the undertaking of any liability by the Seller as regards the SOLAS (Safety Of Life At Sea) Convention. In no event may the said communication be taken to be the VGM (Verified Gross Mass).

E.4.- The Buyer undertakes to ensure that the vehicle sent to the Seller's warehouse is suitable for the loading operations, considering the nature of the products. If the vehicle sent to collect the goods causes difficulties in the loading operations, the Seller reserves the right to charge a penalty, of 4% of the value of the products, to cover the extra logistics costs. If the vehicle sent is not at all suitable, the Seller reserves the right to refuse to load the goods and the Buyer shall not have the right to claim compensation for any direct and/or indirect cost that may arise therefrom.

E.5.- The Buyer is responsible for assigning the carrier the task of checking the products before loading them; any observations concerning the condition of the packaging and the correspondence of the quantities loaded with those on the transport document must be made by the carrier upon collection of the goods. The said observations must be written on all the copies of the transport documents, otherwise the loaded products shall be considered to be complete and in good condition. As a result, the Seller shall not be liable for any missing or damaged

products not reported by the carrier.

E.6.- The Buyer is also responsible for assigning the carrier the task of checking the loading procedure and the stability of the goods on the vehicle, in order to prevent damage during transport and to comply with all road safety provisions.

F.- PAYMENTS

F.1.- All payments must be made to the Seller's registered office. Payments made to agents, representatives, or sales assistants shall not be considered as made until the amounts are received by the Seller.

F.2.- The Buyer shall not fulfil its payment obligations by making payments from countries other than its own country of residence, if the said countries do not guarantee an adequate exchange of information with Italy. In case of breach of the said prohibition, the Seller has the right to terminate the contract for just cause and the Buyer shall not have the right to claim compensation for any damage suffered.

F.3.- Any costs for stamp duty and bank draft fees shall be borne by the Buyer. Failure to fulfil, even only in part, the payment shall result in the application of interest on arrears in favour of the Seller, from the date established for the payment, as envisaged by legislative decree 09/10/2002 no. 231.

F.4.- Unless otherwise agreed in writing, the Buyer undertakes not to offset any receivables, of whatever nature, owed by the Seller.

G.- CLAIMS

G.1.- Upon receipt of the products, the Buyer shall perform a visual inspection in compliance with instructions provided in point 7 of UNI EN ISO 10545-2 standards.

G.2.- The products must be installed and fitted strictly respecting the recommendations related to the activities to be performed before and during the laying of the product specified in document 1) Laying, use, cleaning and maintenance manual, published on the Seller's website, and on the product packaging and/or inside the packaging. Faults caused by an incorrect installation and by missing/incorrect maintenance (different from instructions provided in document 1) Laying, use, cleaning and maintenance manual), by an unsuitable use and/or by normal wear over time shall not be considered product faults.

G.3.- With the exception of the limits of acceptability foreseen by the international EN 14411 (ISO 13006) standard, the parties acknowledge as identifiable faults those product defects that are immediately visible upon receipt thereof and that make the material unsuitable for use or that significantly reduce its value. This category includes faults as defined in the document 1) Laying, use, cleaning and maintenance manual, published on the Seller's website. Identifiable faults include, by way of a non-limiting example, superficial defects, decoration defects, defects concerning polishing, dimensions, surface flatness, straightness of sides/rectangularity and thickness, cracks, chippings or rough edges, non-compliant shades, mixed shades and products that feature problems deriving from the cutting process and/or from chips.

G.4.- If the Buyer finds an identifiable fault, it must be reported in writing to the Seller, within 8 (eight) days from receipt of the products; failure to send the claim shall result in the forfeiture and loss of such right. The Buyer shall keep the entire lot of material readily available for the Seller. The claim shall include the invoice details and an accurate description of the claimed fault together with photographs, where possible. In the event that the claim proves to be unfounded, the Buyer shall refund the Seller any costs incurred for an inspection (expert's reports, travel, etc.).

G.5.- Hidden faults shall be notified to the Supplier in writing, by recorded delivery letter with advice of receipt, within 8 days from the date such fault is found, under penalty of forfeiture.

G.6.- The Buyer's right to make a claim for faults under warranty is valid for 12 (twelve) months from the delivery of the products.

H.- WARRANTY FOR FAULTS

H.1. The Seller's warranty is limited to first grade products and not second or third grade products or lots on offer with special prices or discounts, which must be duly specified with a note in the order confirmation.

H.2. The Seller does not guarantee the suitability of the products for particular uses, and only guarantees the technical specifications published on the website in the document 2) Technical data sheets. The indication for use is merely indicative, even when written in the Seller's catalogues and manuals. On the basis of the characteristics described in the document 2) Technical data sheets, the designer always has the task of assessing the suitability of the product for the specific use conditions, taking into account the stress and variables to which the product will be subjected, which may alter its characteristics; for example, the traffic intensity, quality of traffic (foot traffic with the presence of sand, debris...), adverse weather conditions and any other unpredictable factor to which the material may be exposed.

H.3.- **In the event that identifiable product faults are ascertained, as defined in sub section G no. 3, the Seller shall replace the faulty product with another one with equal or superior characteristics; should this not be possible, the Seller shall apply a significant price reduction. Alternatively, following the return of the faulty products, the Buyer shall have the right to a refund of the price paid plus the transport cost, with the exclusion of compensation for any other direct and/or indirect damage.**

H.4. The Seller's warranty shall not be valid if the products that have identifiable faults (totally or in part) have been used and/or in any case transformed, as this entails that the Buyer (or its customer) expressed the intention to accept them in the condition in which they were found.

H.5.- In the event that hidden product faults are ascertained, the Seller's warranty is limited to the replacement with other products of equal or superior characteristics; should this not be possible the Seller shall refund the price paid plus the transport cost.

In any case, the Seller's warranty for any direct and/or indirect damage caused by the faulty product, shall be limited to an amount that shall not be greater than double the selling price applied by the Seller, only in relation to the faulty part of the supply.

H.6.- In the event that the Buyer resells the product to subjects protected by the consumer code (law decree no. 206/2005), the former shall be responsible for the conditions applied, if different from those stated herein, and shall ensure that the consumer's rights are exercised, in relation to the remedies and terms established by the said code. If there are the grounds for the Buyer to exercise the right of recourse and/or make a claim against the Seller/manufacturer, the said action shall take into account or go beyond the exemptions and limits established in sub sections G no. 1 and H no. 5.

I. SOLVE ET REPETE (PAY AND THEN CLAIM) AND TERMINATION CLAUSES

account may the Buyer suspend or delay payment of collected material, including in the event of alleged defects or faults in the material; this does not affect the right to claim back any payments made unduly (solve et repete).

I.2.- If the Buyer's financial situation changes or in the event of non-payment (even partial) of products already supplied, the Seller reserves the right to suspend the execution of the supplies underway and/or to terminate the contracts in force and the Buyer shall not have the right to claim direct and/or indirect compensation of any type.

L.- RETENTION OF OWNERSHIP

L.1.- The products supplied shall remain exclusive property of the Seller until the Buyer has paid the full amount.

L.2.- During the aforementioned period, the Buyer shall undertake the obligations and responsibilities as bailee (also referred to as custodian) and shall not transfer the said products, grant their use, let them be seized or distrained without declaring that the property is of the Seller, and the Buyer shall immediately inform the Seller by recorded delivery letter with advice of receipt.

M.- FORCE MAJEURE

M.1.- Each party may suspend the fulfilment of its contractual obligations, when the said fulfilment is impossible or objectively too costly due to an unforeseeable impediment independent from the parties, such as for example: strike, boycott, lockout, fire, war (declared or not), civil war, riots and revolutions, requisitions, embargo, power blackouts, extraordinary breakage of machinery, delays in the delivery of components or raw materials.

M.2.- The party that wishes to apply this clause shall immediately notify the onset and end of the circumstances of force majeure to the other party in writing.

M.3.- If the suspension due to force majeure lasts longer than 60 (sixty) days, each party shall have the right to terminate this contract, with a notice of 10 (ten) days to be notified to the counterparty in writing.

N.- CONFIDENTIALITY

N.1.- The Buyer undertakes to maintain confidentiality as regards all information of a technical (such as, by way of a non-limiting example, drawings, tables, documentation, formulas and correspondence) and commercial nature (including contractual conditions, purchase prices, payment conditions,...) gained during the performance of this contract.

N.2.- The confidentiality obligation shall be undertaken for the entire duration of this contract and for the period following its execution.

N.3.- In case of failure to uphold the confidentiality obligation, the non-fulfilling party shall pay the other party compensation for all damages that may derive therefrom.

O.- SELLER'S TRADEMARKS AND DISTINCTIVE SIGNS

O.1.-The use of trademarks, ornamental designs and creative works in general, in whatever form and manner of expression (such as, by way of a non-limiting

example: images, photos, drawings, videos, shapes, structures, etc.) constituting the Seller's intellectual property, through any means (such as, by way of a non-limiting example: press, video, radio, internet, social media, instant messaging platforms or VoIP, etc.) is strictly forbidden. Any exception to the said prohibition, even only partial, must be authorised in writing, each time, by the Seller's general management.

P.- CONTRACT LANGUAGE, APPLICABLE LAW, JURISDICTION AND AUTHORITY

P.1.- The present CONTRACT is drafted in Italian, and in case of disputes the said version shall prevail over any translations in other languages.

P.2.- Any dispute concerning the supply of products shall be subject to Italian law and jurisdiction and the Court of Modena, the town in which the Seller has its registered office, shall have sole local jurisdiction.

CONDITIONS GÉNÉRALES DE VENTE

Rév.1a du 1er Janvier 2018

CERAMICHE
SUPERGRES

A.- MODALITÉS DE CONCLUSION DU CONTRAT

A.1.- Les présentes Conditions Générales de Vente régissent tout contrat de Vente entre le Vendeur et l'Acheteur et toute modification ou dérogation de ces dernières doit être convenue par écrit.

A.2.- D'éventuelles offres, accréditations et / ou ristournes accordées par des agents ou par d'autres intermédiaires, ne seront réputées valables que si elles sont confirmées par écrit par le Vendeur.

A.3.- L'Acheteur envoie au Vendeur, directement ou par l'intermédiaire d'agents, des Commandes écrites qui doivent indiquer les codes des Produits demandés, les quantités, leur prix et leur destination. La commande envoyée par l'Acheteur est irrévocable.

A.4.- La Vente doit être réputée conclue au moment où : (i) l'Acheteur reçoit de la part du Vendeur une Confirmation écrite par e-mail, par télécopie ou par d'autres moyens télématiques, conforme aux conditions de la Commande ; ou (ii) en cas de Confirmation envoyée par le Vendeur contenant des conditions différant de la Commande envoyée par l'Acheteur lorsque celui-ci l'accepte par écrit ou quoi qu'il en soit s'il ne la conteste pas dans un délai de 7 (sept) jours à compter de la réception ; ou (iii) en l'absence d'une confirmation écrite de la part du Vendeur, au moment où les Produits seront livrés et chargés par l'Acheteur.

B.- PRIX

B.1.- Sauf accord contraire, les prix de vente convenus au fur et à mesure sont réputés nets, pour les paiements en espèces et les livraisons Franco l'établissement du Vendeur indiqué sur la Confirmation de Commande.

C.- CARACTÉRISTIQUES DES PRODUITS

C.1.- L'Acheteur déclare avoir lu et s'en tenir au contenu de la documentation suivante publiée sur le site Internet de la société: 1) Manuel de Pose, d'Utilisation, de Nettoyage et d'Entretien et 2) Fiches techniques.

C.2. Vu la variabilité intrinsèque du produit en céramique, les caractéristiques des échantillons et / ou des modèles envoyés précédemment par le Vendeur à l'Acheteur sont indicatifs et non contraignants.

C.3. Sauf en cas de demandes spécifiques à convenir avant la Confirmation de Commande, le Vendeur ne garantit pas la commande d'un article soit intégralement constituée par un même lot de production.

D.- DÉLAIS DE LIVRAISON

D.1.- Les délais de livraison s'entendent fournis à titre indicatif et leur prorogation ne donne en aucun cas le droit à l'Acheteur de demander des indemnisations, excluant dès à présent toute exception.

D.2.- Si l'Acheteur ne retire pas le matériel, au bout d'un délai de 10 (dix) jours à compter de la date de l'annonce indiquant que la marchandise est prête, le Vendeur se réserve la faculté de fixer à sa discrétion un nouveau délai de livraison.

E.- LIVRAISON ET EXPÉDITION

E.1.- L'éventuelle variation de la destination des Produits, différente de celle convenue dans la Confirmation de Commande, doit être communiquée par l'Acheteur par écrit au plus tard le second jour qui précède le jour du retrait au siège du Vendeur. Le Vendeur se réserve la faculté de ne pas accepter la variation de la destination des Produits. Au cas où la destination effective du Produit serait différente de celle déclarée par l'Acheteur, le Vendeur se réserve la faculté de suspendre l'exécution des fournitures en cours et / ou de résilier le contrat sans que l'Acheteur puisse revendiquer des indemnisations directes et / ou indirectes d'aucune sorte.

E.2.- Sauf accord contraire, la fourniture de la marchandise est livrée Départ Usine (EXW aux termes des Incoterms 2010) même si l'on a convenu que l'expédition ou une partie de cette dernière sera suivie par le Vendeur sur mandat de l'Acheteur. En tout état de cause, les risques passent à l'Acheteur au plus tard au moment de la livraison au premier transporteur.

E.3.- Sans préjudice du désintérêt du Vendeur par rapport au contrat de transport, celui-ci ne pourra être indiqué comme le “shipper” dans le connaissance. La communication du poids brut du container à l'expéditeur, ne constitue pas une prise de responsabilité de la part du Vendeur aux fins de la Convention SOLAS (Safety Of Life At Sea). En aucun cas cette communication ne pourra être considérée comme le VGM (Verified Gross Mass).

E.4.- L'Acheteur s'engage à ce que le véhicule envoyé aux entrepôts du Vendeur soit compatible avec la nature des Produits à charger. Si le véhicule qui se présente comporte des difficultés significatives pour les opérations de chargement, le Vendeur se réserve la faculté de débiter une pénalité de l'ordre de 4 % de la valeur des produits pour couvrir les coûts logistiques supplémentaires. Si le véhicule convenu n'est absolument pas compatible, le Vendeur se réserve la faculté de refuser les opérations de chargement sans que l'Acheteur ne puisse rien lui demander à titre de remboursement de toute dépense directe et / ou indirecte éventuelle.

E.5.- Il appartient à l'Acheteur de charger le transporteur de contrôler les produits avant le chargement ; d'éventuelles observations concernant l'intégrité des emballages et la correspondance des quantités chargées avec celles indiquées sur le document de transport doivent être soulevées par le transporteur au moment du chargement. Ces observations doivent être indiquées sur toutes les copies des documents de transport ; dans le cas contraire, les produits chargés sont réputés intacts et complets. Il s'ensuit que le Vendeur décline toute responsabilité en cas d'absence ou de détérioration des produits non signalée par le transporteur.

E.6.- L'Acheteur a également la responsabilité de charger le transporteur de vérifier les modalités et la stabilité du chargement sur le véhicule afin d'éviter les bris durant le transport et le respect de toutes les dispositions de sécurité concernant la circulation sur route.

F.- PAIEMENTS

F.1.- Toute obligation de paiement doit être accomplie au siège légal du Vendeur. Les éventuels paiements remis à des agents, à des représentants ou à des auxiliaires de commerce ne seront réputés effectués qu'au moment où le Vendeur percevra les sommes correspondantes.

F.2.- Il est interdit à l'Acheteur d'effectuer des paiements depuis un pays différent de son pays de résidence et ne garantissant pas un échange d'informations correct avec l'Italie. En cas de violation de cette interdiction, le Vendeur a la faculté de résilier le contrat pour juste cause sans que l'Acheteur ne puisse revendiquer le droit d'obtenir une quelconque réparation pour l'éventuel préjudice subi.

F.3.- Les éventuels frais de timbre et d'encaissement d'effets et de traites sont à la charge de l'Acheteur. En cas de défaillance, même partielle, des intérêts de retard commencent à courir en faveur du Vendeur, à compter du jour fixé pour le paiement, dans la mesure prévue par le Décret Législatif italien n° 231 du 09/10/2002.

F.4.- Sauf accord écrit contraire, l'Acheteur s'engage à ne compenser aucune créance échue.

G.- RÉCLAMATIONS

G.1.- À la réception des Produits, l'Acheteur devra soumettre ces derniers à un contrôle minutieux moyennant un examen visuel effectué conformément aux indications du point 7 des normes UNI EN ISO 10545-2.

G.2.- L'installation et la pose des Produits doivent être effectuées en suivant scrupuleusement les recommandations inhérentes aux activités exercées avant et durant la pose indiquées sur le document 1) Manuel de Pose, d'Utilisation, de Nettoyage et d'Entretien, publié sur le site Internet du Vendeur ainsi qu'à l'extérieur et/ou à l'intérieur de l'emballage du produit. Les défauts dus à une installation erronée et à un entretien absent / erroné (ne respectant pas les indications fournies dans le 1) Manuel de Pose, d'Utilisation, de Nettoyage et d'Entretien), par un usage prévu inapproprié et / ou par l'usure normale due au temps ne sont pas considérés comme des vices du Produit.

G.3.- Sous réserve des limites d'acceptabilité prévues par la norme internationale EN 14411 (ISO 13006), les Parties reconnaissent comme des Vices Évidents les défauts des Produits existant dès la réception de sorte que le matériel devienne inutilisable ou qu'il perde une grande partie de sa valeur. Cette catégorie comprend les défauts définis dans le document 1) Manuel de Pose, d'Utilisation, de Nettoyage et d'Entretien publié sur le site Internet du Vendeur. À titre d'exemple non contraignant, on reconnaît comme des Vices Évidents les défauts de surface, de décoration, de polissage, de calibre, de planéité, d'orthogonalité–rectitude, d'épaisseur, les fissures, les ébréchés, les hors nuance, les nuances mélangées et les Produits qui présentent des problèmes de coupe - voile.

G.4.- Si l'Acheteur relève des Vices Évidents, il devra présenter une réclamation écrite au Vendeur, sous peine de déchéance, dans un délai de 8 (huit) jours à compter de la réception et tenir le lot complet de matériel à la disposition de ce dernier. La réclamation devra indiquer les données de facturation et une description précise du vice objet de la réclamation, accompagnée, si possible, de photographies. Si la réclamation devait s'avérer sans fondement, l'Acheteur est disposé à rembourser au Vendeur les dépenses encourues pour l'éventuelle visite des lieux (expertises, déplacements, etc.).

G.5.- Les Vices Cachés devront être notifiés au Vendeur par lettre recommandée avec avis de réception, sous peine d'annulation de la garantie, dans un délai de 8 (huit) jours à compter de la date de la découverte du défaut.

G.6.- L'action de l'Acheteur ayant pour but de faire valoir la garantie en cas de vices se prescrit dans un délai de 12 (douze) mois à compter de la livraison des Produits.

H.- GARANTIE COUVRANT LES VICES

H.1. La garantie du Vendeur est réputée limitée aux seuls Produits de premier choix et non aux Produits de second ou de troisième choix ou à des lots d'occasion auquel on applique des prix ou des remises particuliers lorsqu'ils sont dûment signalés dans les notes de la Confirmation de Commande.

H.2. Le Vendeur ne garantit pas l'adéquation des Produits à des usages particuliers, mais uniquement les caractéristiques techniques publiées sur le site Internet dans

le document 2) Fiches techniques. L'usage indiqué, également lorsqu'il est présenté par le Vendeur dans des catalogues et des manuels, est purement indicatif. Sur la base des caractéristiques techniques indiquées dans les 2) Fiches Techniques, le concepteur a toujours le devoir d'évaluer l'adéquation du Produit aux conditions spécifiques d'utilisation en fonction des contraintes et des variables pouvant se vérifier dans le lieu de destination et susceptibles d'en altérer les caractéristiques, par exemple, l'intensité et la qualité de la circulation (piétinement en présence de sable, de détritrus...), ainsi que les éventuelles conditions climatiques défavorables et toute autre incidence à laquelle peut être exposé le matériel.

H.3.- **Si l'on a constaté que le Produit présente les Vices Évidents définis à la lettre G n°3, le Vendeur remplacera le Produit défectueux par un autre produit ayant des caractéristiques analogues ou supérieures ou, lorsque cela est impossible, à une réduction cohérente du prix. En alternative, l'Acheteur aura droit, après la restitution des Produits défectueux, au remboursement du prix payé, majoré du prix du transport, à l'exclusion du remboursement de tout autre préjudice direct et / ou indirect.**

H.4. **La garantie du Vendeur doit être réputée exclue au cas où le Produit présentant des Vices Évidents (entièrement ou partiellement) aurait été utilisé et / ou du moins transformé ; dans ce cas, on considérera que l'Acheteur (ou son client) a exprimé la volonté de les accepter en l'état.**

H.5 Si l'on a constaté que le Produit présente des Vices Cachés, la garantie du Vendeur se limite au remplacement du matériel par du matériel ayant des caractéristiques analogues ou supérieures et, lorsque cela est impossible, au remboursement du prix payé majoré des frais de transport. direct et / ou indirect causé par le produit défectueux, se limitera à une somme qui ne pourra pas dépasser le double du prix de vente appliqué par le Vendeur dans le cadre de la seule partie de la fourniture défectueuse.

H.6.- Si l'Acheteur revend le Produit à des clients protégés par le code de la consommation (Décret-loi italien n° 206/2005) il sera responsable des conditions appliquées si celles-ci diffèrent des conditions indiquées ici et il devra s'assurer que les droits du consommateur sont exercés dans le respect des remèdes et des délais fixés par ce code. Si les conditions sont réunies, le droit de retrait et / ou de recours revenant à l'Acheteur à l'encontre du Vendeur / fabricant ne pourra dépasser ni les exonérations ni les limites établies de la lettre G n°1 à la lettre H n°5.

I. CLAUSES SOLVE ET REPETE ET CLAUSES RÉSOLUTOIRES

I.1.- Aux termes de l'art. 1462 du Code Civil italien, en aucun cas, y compris les prétendus vices ou défauts du matériel, l'Acheteur ne pourra suspendre ou retarder le paiement du matériel retiré, sans préjudice naturellement de la faculté d'exiger lorsqu'il est en mesure de démontrer avoir indûment payé.

I.1.- En cas de variation des conditions patrimoniales de l'Acheteur ou de non-paiement même partiel de produits déjà fournis, le Vendeur se réserve la faculté de suspendre l'exécution des fournitures en cours et / ou de résilier les contrats sans que l'Acheteur ne puisse revendiquer des indemnisations directes et / ou indirectes d'aucune sorte.

L.- PACTE DE RÉSERVE DE PROPRIÉTÉ

L.1.- Tant que l'Acheteur n'aura pas intégralement payé le prix, les Produits objet de la fourniture resteront la propriété du Vendeur.

L.2.- Au cours de la susdite période, l'Acheteur assumera les obligations et les responsabilités de gardien, et il ne pourra ni aliéner, ni confier, ni permettre la saisie desdits Produits sans déclarer la propriété du Vendeur et informer immédiatement ce dernier par lettre recommandée avec avis de réception.

M.- FORCE MAJEURE

M.1.- Chacune des parties pourra suspendre l'accomplissement de ses obligations contractuelles lorsque cette exécution est rendue impossible ou objectivement trop onéreuse par un empêchement imprévisible indépendant de sa volonté comme : les grèves, les boycottages, les lock-outs, les incendies, les guerres (déclarées ou non), les guerres civiles, les révoltes et les révolutions, les réquisitions, les embargos, les coupures de courant, les ruptures exceptionnelles de machines, les retards de livraison de composants ou de matières premières.

M.2.- La partie qui souhaite user de la présente clause devra communiquer immédiatement par écrit à l'autre partie la survenue et la cessation des circonstances de force majeure.

M.3.- Si la suspension due à une force majeure dure plus de 60 (soixante) jours, chacune des parties aura le droit de résilier le présent contrat, avec un préavis de 10 (dix) jours, en le communiquant par écrit à la partie adverse.

N.- OBLIGATIONS DE CONFIDENTIALITÉ

N.1.- L'Acheteur est tenu d'observer le secret le plus absolu concernant toutes les informations de caractère technique (comme, par exemple, les dessins, les notices, les documentations, les formules et la correspondance) et de caractère commercial (y compris les conditions contractuelles, les prix d'achat, les conditions

de paiement, etc.) dont il aurait eu connaissance durant l'exécution du présent Contrat.

N.2.- L'obligation de confidentialité est assumée pendant toute la durée du Contrat, ainsi que pour la période successive à son exécution.

N.3.- Dans tous cas de non-observation de l'obligation de confidentialité, la partie défaillante est tenue de réparer à l'autre partie tous les éventuels préjudices.

O.- MARQUES ET SIGNES DISTINCTIFS DU VENDEUR

O.1.- L'utilisation des marques, des modèles ornementaux et des œuvres de l'esprit en général, sous quelque forme ou suivant quelque modalité d'expression que ce soit (à titre d'exemple, non contraignant : les images, les photos, les dessins, les vidéos, les figures, les structures, etc.) constituant la propriété intellectuelle du Vendeur, à travers tout moyen (à titre d'exemple non contraignant : l'impression, la vidéo, la radio, Internet, les médias sociaux, les plates-formes de messagerie instantanée ou VoIP, etc.) est formellement interdite. Toute dérogation à cette interdiction, même partielle, devra être autorisée par écrit, cas par cas, par la Direction générale du Vendeur.

P.- LANGUE DU CONTRAT, LOI APPLICABLE, JURIDICTION ET COMPÉTENCE

P.1.- Le Contrat et les présentes conditions sont rédigés en langue italienne qui prévaudra en cas de divergence avec la traduction dans d'autres langues.

P.2.- La définition de toute controverse relative aux fournitures est régie par la loi et la juridiction de l'État italien et les parties reconnaissent la compétence territoriale exclusive du Tribunal de Modène dans la circonscription duquel se trouve le siège légal du Vendeur.

ALLGEMEINE VERKAUFSBEDINGUNGEN

Fassung 1.a vom 1. Januar 2018

CERAMICHE
SUPERGRES

A.- MODALITÄT DES VERTRAGSABSCHLUSSES

A.1.- Die vorliegenden Allgemeinen Verkaufsbedingungen regeln alle Verträge zwischen dem Verkäufer und dem Käufer und alle Änderungen oder Abweichungen davon müssen schriftlich vereinbart werden.

A.2.- Eventuelle Angebote sowie mit Handelsvertretern oder sonstigen Vermittlern vereinbarten Gutschriften sind nicht verbindlich, es sei denn, sie werden vom Verkäufer schriftlich bestätigt.

A.3.- Der Käufer sendet dem Verkäufer direkt oder über Handelsvertreter schriftliche Bestellungen zu, die die Angabe der Artikelnummern der gewünschten Produkte, der Mengen, ihres Preises und der Bestimmung enthalten müssen. Die vom Käufer gesendete Bestellung ist unwiderrüflich.

A.4.- Der Verkauf gilt zu dem Zeitpunkt als abgeschlossen, an dem: (i) der Käufer vom Verkäufer eine schriftliche Bestätigung per E-Mail, Fax oder auf sonstigem Weg erhält, die den Fristen und Bedingungen der Bestellung entspricht; oder (ii) falls die vom Verkäufer gesendete Bestätigung, Bedingungen enthält, die von der vom Käufer erhaltenen Bestellung abweichen, wenn dieser diese akzeptiert oder nicht innerhalb von 7 (sieben) Tagen ab ihrem Empfang beanstandet; oder (iii) falls keine schriftliche Bestätigung durch den Verkäufer erfolgt, zu dem Zeitpunkt, an dem die Produkte geliefert und vom Käufer übernommen werden.

B.- PREISE

B.1.- Vorbehaltlich abweichender schriftlicher Vereinbarungen gelten die von Mal zu Mal vereinbarten Verkaufspreise als Nettobarpreise bar mit Lieferung frei ab dem in der Auftragsbestätigung angegebenen Werk des Verkäufers.

C.- EIGENSCHAFTEN DER PRODUKTE

C.1.- Der Käufer erklärt, die folgende auf der Web-Site des Unternehmen veröffentlichte Dokumentation zur Kenntnis genommen zu haben und sich an deren Inhalt zu halten: 1) Handbuch zur Verlegung, Benutzung, Reinigung und Pflege, und 2) Technische Datenblätter.

C.2. Aufgrund der intrinsischen Variabilität des Keramikprodukts sind die Eigenschaften der vorausgehend vom Verkäufer an den Käufer gesendeten Warenmuster und/oder Modelle hinweisend und unverbindlich.

C.3. Vorbehaltlich spezifischer Vereinbarungen vor der Auftragsbestätigung garantiert der Verkäufer nicht, dass die Lieferung des einzelnen Artikels vollständig mit dem gleichen Produktionslos ausgeführt wird.

D.- LIEFERFRISTEN

D.1.- Die Lieferfristen sind unverbindlich und Verzögerungen führen für den Käufer in keinem Fall zum Anspruch auf Schadensvergütung.

D.2.- Falls der Käufer das Material nicht innerhalb von 10 (zehn) Tagen ab dem Datum der Bereitstellung der Waren abholt, behält sich der Verkäufer das Recht vor, eine neue Lieferfrist festzusetzen.

E.- RÜCKLIEFERUNG UND VERSAND

E.1.- Die eventuelle Änderung des Bestimmungsortes der Produkte, die sich von der in der Auftragsbestätigung vereinbarten unterscheidet, muss vom Käufer schriftlich innerhalb des zweiten Tags vor dem für die Abholung am Sitz des Verkäufers vorgesehenen mitgeteilt werden. Der Verkäufer behält sich das Recht vor, die Änderung der Bestimmung der Produkte nicht zu akzeptieren. Falls sich herausstellt, dass die effektive Bestimmung des Produkts von der vom Käufer angegebenen verschieden ist, behält sich der Verkäufer das Recht vor, die laufenden Lieferungen nicht auszuführen und/oder die laufenden Verträge aufzulösen, ohne dass der Käufer jeglichen Anspruch auf Entschädigung geltend machen kann.

E.2.- Vorbehaltlich abweichender Vereinbarungen erfolgt die Lieferung der Ware frei ab Werk (EXW gemäß den Incoterms 2010), und dies auch, falls vereinbart wird, dass der Versand oder ein Teil desselben im Auftrag des Käufers durch den Verkäufer erfolgt. In jedem Fall gehen die Risiken spätestens mit der Übergabe an das erste Transportunternehmen an den Käufer über.

E.3.- Unter Beibehaltung der Nichtbeteiligung des Verkäufers am Transportvertrag kann der Verkäufer in der Police der Ladung als „Shipper“ angegeben werden. Die Mitteilung des Bruttogewichts des Containers an den Transportunternehmer stellt keine Übernahme der Verantwortung des Verkäufers hinsichtlich der SOLAS-Konvention dar (Safety Of Life At Sea). In keinem Fall kann diese Mitteilung als VGM (Verified Gross Mass) verstanden werden.

E.4.- Der Käufer verpflichtet sich sicherzustellen, dass das zu den Lagern des Verkäufers gesendete Fahrzeug unter Berücksichtigung der Natur der Produkte für das Laden geeignet ist. Falls das zum Laden gesendete Fahrzeug größere Probleme beim Beladen bereitet, behält der Verkäufer sich das Recht vor, zur Abdeckung der höheren Logistikkosten eine Vertragsstrafe in Höhe von 4 % des Werts der Produkte zu erheben. Falls das Fahrzeug vollkommen ungeeignet ist, behält sich der Verkäufer das Recht vor, das Verladen zu verweigern, ohne dass der Käufer einen Anspruch auf Vergütung der Schäden geltend machen kann, die direkt und/oder indirekt daraus entstehen können.

E.5.- Es ist Aufgabe des Käufers, das Transportunternehmen zu beauftragen und die Produkte vor dem Laden zu kontrollieren; eventuelle Anmerkungen zur Unversehrtheit der Verpackungen und der Übereinstimmung der geladenen Menge mit der in den Transportpapieren angegebenen müssen vom Transportunternehmen zum Zeitpunkt des Ladens vorgenommen werden. Diese Anmerkungen müssen auf alle Exemplare der Transportpapiere vermerkt werden, anderenfalls gelten die geladenen Produkte als unbeschädigt und vollständig. Daraus folgt, dass der Verkäufer keinerlei Haftung für Fehlmengen oder Beschädigungen der Produkte übernimmt, die vom Transportunternehmen nicht gemeldet werden.

E.6.- Es ist ebenfalls Aufgabe des Käufers, das Transportunternehmen zu beauftragen und die Modalität und die Stabilität des Ladens auf das Fahrzeug zu überprüfen, damit es während des Transports nicht zu Brüchen kommt, sowie die Einhaltung der Sicherheitsbestimmungen der Straßenverkehrsordnung zu gewährleisten.

F.- ZAHLUNGEN

F.1.- Alle Zahlungsverpflichtung müssen am Firmensitz des Verkäufers erfüllt werden. Eventuelle Zahlungen an Handelsvertreter oder Außendienstmitarbeiter gelten als nicht geleistet, bis sie beim Verkäufer eingehen.

F.2.- Es ist dem Käufer untersagt, die Zahlungen aus Ländern vorzunehmen, die vom Land seines Firmensitzes verschieden sind, falls diese Länder keinen angemessenen Informationsaustausch mit Italien gewährleisten. Im Fall der Verletzung dieses Verbots hat der Verkäufer das Recht, den Vertrag aus gutem Grund aufzulösen, ohne dass der Käufer eine Vergütung des entstandenen Schadens geltend machen kann.

F.3.- Eventuelle Kosten und Gebühren für die Einziehung von Effekten und Wechseln gehen zu Lasten des Käufers. Im Fall der Nichteinhaltung des für die Zahlung festgesetzten Tags – auch nur partiell – fallen Säumniszinsen zu Gunsten des Verkäufers an, in der vom ital. Gesetzlerlass vom 9. Oktober 2002, Nr. 231 vorgesehenen Höhe.

F.4.- Vorbehaltlich abweichender schriftlicher Vereinbarungen verpflichtet sich der Käufer, keine Guthaben gegenüber dem Verkäufer zu verrechnen.

G.- BEANSTANDUNGEN

G.1.- Beim Empfang der Produkte muss der Käufer sie einer sorgfältigen Sichtkontrolle gemäß den Angaben von Punkt 7 der Normen UNI EN ISO 10545-2 unterziehen.

G.2.- Die Installation und die Verlegung der Produkte müssen unter Einhaltung der Empfehlungen zu den Arbeiten ausgeführt werden, die vor und während der Verlegung ausgeführt werden müssen, wie angegeben im Dokument 1) Handbuch zur Verlegung, Verwendung, Reinigung und Pflege, veröffentlicht auf der Web-Site des Verkäufers und angegeben auf der Verpackung des Produkts und/oder im Inneren derselben. Schäden, die durch eine falsche Installation, Verlegung und durch eine unterlassene/falsche Pflege (abweichend von den Angaben in 1) Handbuch zur Verlegung, Reinigung und Wartung), durch eine ungeeignete Gebrauchsbestimmung oder durch normale Abnutzung verursacht werden, werden nicht als Mängel des Produkts anerkannt.

G.3.- Vorbehaltlich der Grenzen der Akzeptabilität, die von der internationalen Norm EN 14411 (ISO 13006) vorgesehen sind, erkennen die Parteien Mängel der Produkte als offensichtliche Mängel an, die bereits bei ihrem Empfang festgestellt werden können, die das Material zur Verwendung ungeeignet machen oder die den Wert beträchtlich verringern. In diese Kategorie fallen Mängel, wie im Dokument definiert 1) Handbuch zur Verlegung, Benutzung, Reinigung und Pflege, veröffentlicht auf der Web-Site des Verkäufers. Als nicht erschöpfende Beispiele werden Oberflächenmängel, fehlerhafte Grafik, Defekte polierte Oberfläche, Defekte des Kalibers, der Planarität, der Rechtwinkligkeit/Gradlinigkeit, der Stärke, Risse, abgeschlagene Kanten, Fehlerfarbe, gemischte Brandfarbe sowie Produkte mit Kantsplitterung durch Rettifizierung als offensichtliche Mängel anerkannt.

G.4.- Falls der Käufer offensichtliche Mängel feststellt, muss er dies dem Verkäufer innerhalb von 8 (acht) Tagen ab dem Empfang schriftlich melden und die gesamte Charge des Materials für den Verkäufer zur Verfügung halten; anderenfalls verfällt der Rechtsanspruch. Bei der Beanstandung müssen die Daten der Rechnung sowie eine präzise Beschreibung des beanstandeten Mangels angegeben werden, falls möglich mit einer fotografischen Dokumentation. Falls die Beanstandung unberechtigt sein sollte, ist der Käufer gehalten, dem Verkäufer die für einen eventuellen Ortstermin aufgewendeten Kosten (Gutachten, Reisekosten, usw.) zu erstatten.

G.5.- Versteckte Mängel müssen dem Verkäufer innerhalb von 8 (acht) Tagen ab Feststellung des Mangels per Einschreiben mit Rückschein gemeldet werden; anderenfalls verfällt der Rechtsanspruch.

G.6.- Die Aktion des Käufers zur Inanspruchnahme der Mängelhaftung muss in jedem Fall innerhalb von 12 (zwölf) Monaten ab der Lieferung der Produkte erfolgen.

H.- MÄNGELHAFTUNG

H.1. Die Garantie des Verkäufers ist begrenzt auf Produkte erster Qualität und sie bezieht sich nicht auf Produkte zweiter oder dritter Qualität oder auf gelegentliche Partien mit besonderen Preisen oder Nachlässe, die in der Auftragsbestätigung angegeben werden.

H.2. Der Verkäufer garantiert nicht die Eignung der Produkte für besondere Verwendungen, sondern lediglich die technischen Eigenschaften, die auf der Web-Site in Dokument 2) Technische Datenblätter veröffentlicht sind. Die Angabe zur Verwendung ist als unverbindlich anzusehen, auch wenn vom Verkäufer in Katalogen und Handbüchern angegeben ist. Es ist stets Aufgabe des Planers, auf der Grundlage der in den 2) Technischen Datenblättern angegebenen Eigenschaften die Eignung des Produkts für spezifische Nutzungsbedingungen zu bewerten, unter Berücksichtigung der Belastungen sowie der Variablen, die am Ort der Bestimmung auftreten und die Eigenschaften verändern können, wie zum Beispiel die Intensität des Verkehrs, die Qualität des Verkehrs (Begehung bei Vorhandensein von Sand, Schmutz usw.), die eventuellen klimatischen Bedingungen sowie alle sonstigen Einflüsse, denen das Material ausgesetzt sein kann.

H.3.- **Falls festgestellt wird, dass das Produkt offensichtliche Mängel aufweist, wie definiert in Punkt G, Nr. 3, nimmt der Verkäufer die Ersetzung des mangelhaften Produkts durch ein anderes mit gleichen oder höherwertigen Eigenschaften vor, oder er nimmt eine angemessene Reduzierung des Preises vor, falls dies nicht möglich ist. Alternativ hat der Käufer nach Rücklieferung der mangelhaften Produkte das Recht auf Rückerstattung des bezahlten Preises, zuzüglich der Transportkosten, mit Ausschließung der Vergütung aller direkten und/oder indirekten Schäden.**

H.4. **Die Garantie des Verkäufers wird ausgeschlossen, falls das mangelhafte Produkt (ganz oder teilweise) verwendet und/oder umgewandelt worden ist, da davon ausgegangen wird, dass der Käufer (oder sein Kunde) dadurch seinen Willen zum Ausdruck gebracht hat, es in dem Zustand zu akzeptieren, in dem es sich befindet.**

H.5. **Falls festgestellt wird, dass das Produkt versteckte Mängel aufweist, ist die Garantie des Verkäufers auf die Ersetzung des Materials durch anderes mit gleichen oder höherwertigeren Eigenschaften beschränkt oder – falls dies nicht möglich ist – auf die Rückerstattung des bezahlten Preises, zuzüglich der Transportkosten.** In jedem Fall ist die Garantie des Verkäufers für alle direkten und/oder indirekten Schäden, die durch das mangelhafte Produkt entstehen, auf einen Betrag begrenzt, der das Doppelte des Verkaufspreises nicht übersteigen kann, den der Verkäufer auf den mangelhaften Teil der Lieferung angewendet hat.

H.6.- Falls der Käufer das Produkt an Kunden weiterverkauft, die vom Verbraucherschutzgesetz (ital. Gesetzlerlass Nr. 206/2005) geschützt werden, ist er verantwortlich für die angewendeten Bedingungen, falls diese von den hier angegebenen abweichen, und er muss sicherstellen, dass die Rechte des Verbrauchers gemäß den Bestimmungen dieses Gesetzes ausgeübt werden können. Falls die Voraussetzungen gegeben sind, kann das Regressrecht des Käufers gegenüber dem Verkäufer/Hersteller nicht die Grenzen übersteigen, die von Punkt G, Nr. 1 bis Punkt H, Nr. 5 angegeben werden.

I. KLAUSEL SOLVE ET REPETE UND AUFLÖSUNGSKLAUSEL

I.1.- Gemäß den Bestimmungen von § 1462 des ital. Bürgerlichen Gesetzbuches kann der Käufer in keinem Fall – einschließlich von vermeintlichen Mängeln oder Defekten des Materials – die Zahlung des abgenommenen Materials aussetzen oder verzögern, natürlich vorbehaltlich des Rechts, ungerechtfertigt gezahlte Beträge zurückzufordern, und dies nur nach Erbringung des Nachweises der Rechtmäßigkeit der Forderung (Solve et Repete).

I.2.- Im Fall der Veränderung der Vermögensbedingungen des Käufers oder der auch nur partiellen Nichtbezahlung der bereits gelieferten Produkte kann der Verkäufer die laufenden Lieferungen aussetzen und/oder die laufenden Verträge auflösen, ohne dass der Käufer die Vergütung von direkten und/oder indirekten Schäden geltend machen kann.

L.- EIGENTUMSVORBEHALT

L.1.- Bis zur vollständigen Bezahlung des Preises durch den Käufer bleiben die Produkte, die den Gegenstand der Lieferung darstellen, Eigentum des Verkäufers.

L.2.- Während dieses Zeitraums übernimmt der Käufer die Pflichten und die Verantwortlichkeiten für die Aufbewahrung der gekauften Produkte und er kann sie nicht veräußern, zur Nutzung überlassen oder beschlagnahmen oder pfänden lassen, ohne das Eigentum des Verkäufers anzugeben und ohne diesen umgehend per Einschreiben mit Rückschein zu benachrichtigen.

M.- HÖHERE GEWALT

M.1.- Beide Parteien können die Ausführung der vertraglichen Pflichten aussetzen, wenn die Ausführung aus Gründen, die vom eigenen Willen unabhängig sind, unmöglich oder objektiv zu aufwendig wird, wie zum Beispiel: Streiks, Boykott, Aussperrung, Brand, Krieg (erklärt oder nicht), Bürgerkrieg, Aufstände und

Revolutionen, Beschlagnahme, Embargo, Unterbrechungen der Energieversorgung, außerordentliche Defekte von Maschinen, Verspätung bei der Anlieferung von Komponenten und Rohstoffen.

M.2.- Die Partei, die beabsichtigt, die vorliegende Klausel in Anspruch zu nehmen, muss der anderen Partei schriftlich das Auftreten von Umständen der Höheren Gewalt mitteilen.

M.3.- Falls die Aussetzung aufgrund von Höherer Gewalt mehr als 60 (sechzig) Tage andauert, haben beiden Parteien das Recht, den vorliegenden Vertrag nach einer schriftlichen Vorankündigung von 10 (zehn) Tagen an die Gegenpartei aufzulösen.

N.- VERTRAULICHKEITSPFLICHT

N.1.- Der Käufer ist gehalten, über alle technischen Informationen (wie zum Beispiel Zeichnungen, Prospekte, Dokumentationen, Formeln und Schriftverkehr) und kommerziellen Informationen (einschließlich der Vertragsbedingungen, der Kaufpreise, der Zahlungsbedingungen usw.), in deren Kenntnis während der Ausführung des vorliegenden Vertrages kommt, absolute Vertraulichkeit einzuhalten.

N.2.- Die Vertraulichkeitspflicht wird für die Dauer des Vertrages sowie den Zeitraum nach seiner Ausführung übernommen.

N.3.- Im Fall der Nichteinhaltung der Vertraulichkeitspflicht ist die nicht einhaltende Partei gehalten, der anderen Partei alle daraus entstehenden Schäden zu vergüten.

O.- MARKEN UND KENNZEICHNUNGEN DES VERKÄUFERS

O.1.-Die Verwendung von Marken, Ziermotiven und geistigem Eigentum im Allgemeinen in jeder Form sowie jeder Ausdrucksform (als nicht erschöpfendes Beispiel: Bilder, Fotos, Zeichnungen, Filme, Abbildungen, Strukturen usw.), die intellektuelles Eigentum des Verkäufers sind, ist auf jede Weise (als nicht erschöpfendes Beispiel: Presse, Video, Radio, Internet, Social Media, Instant-Message-Plattform oder VoIP usw.) strengstens untersagt. Alle – auch nur partielle – Abweichungen von diesem Verbot müssen von Fall zu Fall schriftlich von der Generaldirektion des Verkäufers autorisiert werden.

P.- SPRACHE DES VERTRAGS, ANWENDBARES RECHT, RECHTSPRECHUNG UND GERICHTSSTAND

P.1.- Der Vertrag und die vorliegenden Bedingungen werden in italienischer Sprache verfasst, die im Fall der Abweichung der Übersetzung in andere Sprachen Vorrang hat.

P.2.- Die Regelung aller Rechtssachen hinsichtlich den Lieferungen unterliegt der Rechtsprechung des italienischen Staats und die territoriale Zuständigkeit liegt ausschließlích beim Bezirksgericht Modena, dem Ort des Firmensitzes des Verkäufers.

Tabella 2 - vizi palesi / Table 2 – visible defects / tableau 2 – vices apparents / tabelle 2 - offensichtliche mängel

CAUSALE / TYPE OF DEFECT / MOTIF / GRUND	DESCRIZIONE / DESCRIPTION / DESCRIPTION / BESCHREIBUNG /	ECCEZIONI / EXCEPTIONS / EXCEPTIONS / AUSNAHMEN
CALIBRO CALIBER CALIBRE WERKMASS	Piastrelle di dimensioni (Larghezza/Lunghezza) differenti all'interno dello stesso lotto (Calibro/Caliber) con deviazioni superiori alle tolleranze rivendicate in scheda tecnica. / Tiles with different dimensions (Width/Length) in the same batch (Caliber), with deviations exceeding the tolerances claimed on the technical specification sheet. / Carreaux de dimensions différentes (Largeur/Longueur) à l'intérieur du même lot (Calibre) avec des déviations supérieures aux tolérances indiquées dans la fiche technique. / Fliesen verschiedener Abmessungen (Breite/Länge) innerhalb eines Loses (Werkmaß), wobei die Abweichungen die im technischen Datenblatt angegebenen Toleranzen überschreiten.	/
PLANARITA' PLANARITY PLANÉITÉ EBENHEIT	Piastrelle concave o convesse (curvatura dello spigolo), con angoli rialzati o abbassati (svergolamento) con deviazioni superiori rispetto alle tolleranze rivendicate in scheda tecnica. / Tiles that are concave or convex (curved at the edges), have raised or lowered corners (warpage) with deviations exceeding the tolerances claimed on the technical specification sheet. / Carreaux concaves ou convexes (courbure de l'arête), avec des angles rehaussés ou abaissés (gauchissement) avec des déviations supérieures aux tolérances indiquées dans la fiche technique. / Konkave oder konvexe Fliesen (Krümmung der Kante), mit erhöhten oder abgesenkten Winkeln (verzogene Fliesen), wobei die Abweichungen die im technischen Datenblatt angegebenen Toleranzen überschreiten.	/
ORTOGONALITA'- RETTILINEITA' ORTHOGONALITY – STRAIGHTNESS ORTHOGONALITÉ – RECTITUDE RECHTWINKELIGKEIT-GERADLIGKEIT	Piastrelle con lati non rettilinei e non ortogonali ("effetto trapezio") con deviazioni superiori rispetto alle tolleranze rivendicate in scheda tecnica. / Tiles with edges that are not straight (and not orthogonal ("trapezoid effect")) with deviations exceeding the tolerances claimed in the technical specification sheets. / Carreaux avec des bords non rectilignes et non orthogonaux (« effet trapèze ») avec des déviations supérieures aux tolérances indiquées dans la fiche technique. / Fliesen mit nicht geraden und nicht rechtwinkligen Seiten („Trapezeffekt“), wobei die Abweichungen die im technischen Datenblatt angegebenen Toleranzen überschreiten.	/
SPESSORE THICKNESS ÉPAISSEUR STÄRKE	Piastrelle con spessore differente all'interno della stessa scatola con deviazioni superiori rispetto alle tolleranze rivendicate in scheda tecnica. / Tiles with differing thicknesses in the same box with deviations exceeding the tolerances claimed on the technical specification sheet. / Carreaux d'épaisseurs différentes à l'intérieur de la même boîte avec des déviations supérieures aux tolérances. / Fliesen mit unterschiedlicher Stärken innerhalb einer Kiste, wobei die Abweichungen die im technischen Datenblatt angegebenen Toleranzen überschreiten.	/
CREPE CRACKS CRAQUELURES RISSE	Piastrelle con crepe parallele o ortogonali al bordo oppure superficiali con immediato distacco di placche superficiali dopo battitura. / Tiles with cracks running parallel or orthogonally to the edge, or surface cracks leading to the immediate detachment of bits of the surface coating when the tiles are tapped to level the surface. / Carreaux avec des craquelures parallèles ou orthogonales sur leur bord ou leur surface avec un détachement immédiat de plaques superficielles après le battage. / Fliesen mit parallelen oder rechtwinkligen Rissen an den Kanten oder auf der Oberfläche mit sofortigem Abplatzen von oberflächlichen Stückchen beim Anklopfen.	/
SBECCATURE CHIPPING FISSURES DELLEN, ANGESCHLAGENE FLI- SEN	Piastrelle con angoli e/o bordi rotti dentro alle scatole. / Tiles with broken corners and/or edges inside the box. / Carreaux avec des angles et/ou des bords cassés à l'intérieur des boîtes. / Fliesen mit angeschlagenen Ecken und/oder Kanten in den Kisten.	/

CAUSALE / TYPE OF DEFECT / MOTIF / GRUND	DESCRIZIONE / DESCRIPTION / DESCRIPTION / BESCHREIBUNG	ECCEZIONI / EXCEPTIONS / EXCEPTIONS / AUSNAHMEN
DIFETTI SUPERFICIALI SURFACE DEFECTS DÉFAUTS DE SURFACE OBERFLÄCHLICHE MÄNGEL	Piastrella con buchi, spillature, crateri, vulcani, avvallamenti, inquinamento di impasto e presenza della marca (impressa dal retro del materiale ceramico) sulla superficie di esercizio. / Tiles with (pin) holes, depressions, dimples, puckering, any contamination in the ceramic body; visible signs of brands/trademarks (left by the back of other ceramic tiles) on the surface. / Carreaux avec trous, coulées, creux, bosses, dépressions, contamination de la pâte et avec présence de la marque (imprimée par le dos du matériau céramique) sur la surface d'utilisation. / Fliese mit Löchern, kleinen nadelstichförmigen Vertiefungen, Kratern, Einsenkungen, verschmutzter Masse und Sichtbarkeit der Marke (durchgedrückt von der Rückseite des Keramikmaterials) auf der Oberfläche.	Il segno delle ventose visibile solo in condizioni di umidità per pochi secondi non viene considerato come difetto della piastrella in quanto nelle normali condizioni di esercizio / If suction pads leave visible signs for a few seconds in humid conditions, this is not considered a defect of the tile, as such signs are not visible in normal conditions. / La marque des ventouses, visible uniquement dans des conditions d'humidité pendant quelques secondes, n'est pas considérée comme un défaut dans la mesure où celle-ci ne se voit pas dans des conditions normales d'utilisation. / Die nur bei Feuchtigkeit für einige Sekunden sichtbare Saugnapfmarkierung gilt nicht als Mangel der Fliese, da sie unter normalen Bedingungen nicht wahrgenommen wird
DIFETTO DI DECORAZIONE DECORATIVE DEFECTS DÉFAUT DE DÉCORATION DEKORATIONSMÄNGEL	Piastrelle con difetti di serigrafia, di smalto, gocce, righe della digitale... / Tiles with defects in the silk-screen printing, glazing, droplets and lines created during digital printing. / Carreaux avec des défauts de sérigraphie, d'émail, de gouttes et de lignes de la machine numérique. / Fliesen mit Fehlern im Druck, der Glasur, Tropfen, Streifen bei Digitaldruck	/
FUORI TONO COLOUR DEFECTS HORS TON FARBTONFEHLER FUERA DE TONO РАЗНОТОННОСТЬ	Piastrelle con tono eccessivamente diverso dal riferimento e/o campione fornito al cliente. / Tiles with a tone of colour that differs excessively from the reference piece and/or sample provided to the customer. / Carreaux avec un ton excessivement différent de la référence et/ou de l'échantillon fourni au client. / Fliesen mit einem Ton, der sich zu sehr von der Referenz und/oder dem Muster unterscheidet, das dem Kunden geliefert wurde.	/
TONI MESCOLATI MIXED TONES TONS MÉLANGÉS VERMISCHTE FARB TÖNE TONOS MEZCLADOS СМЕШАННЫЕ ТОНА	Piastrelle all'interno dello stesso lotto con un grado di stonizzazione superiore al V-Shade riportato a catalogo. / Tiles in the same batch with a colour shading level above the V-Shade stated in the catalogue. / Carreaux à l'intérieur du même lot avec un degré de dénuançage supérieur au V-Shade mentionné dans le catalogue. / Fliesen innerhalb derselben Partie mit Farbabweichungen, die größer sind als der im Katalog angegebene V-Shade-Wert.	/
DIFETTO DI LAPPATURA/LEVIGATURA LAPPING/POLISHING DEFECTS DÉFAUT DE LUSTRAGE/POLISSAGE LÄPPUNGS-/POLIERFEHLER	Piastrelle con "bucatura" eccessiva, "pelate" (affioramento del colore dell'impasto), bordi graffiati e/o opachi, graffi superficiali di forma semicircolare... / Tiles on which the surface presents an excessive number of "pinholes" or appears to "peel" (the colour of the ceramic body resurfaces), that have scratched and/or opaque edges, surface scratches of a semicircular shape, ... / Carreaux avec une quantité excessive de trous, « pelades » (apparition de la couleur de la pâte), bords rayés et/ou opaques, rayures superficielles de forme semi-circulaire, ... / Fliesen mit übermäßigen Einstichen abgeblätterte Fliesen (Farbe des Scherbens schlägt durch), verkratzte und/oder matte Kanten, halbrunde oberflächliche Kratzer usw.	/
PROBLEMI DA TAGLIO - SCAGLIE CUTTING PROBLEM – FLAKING PROBLÈMES DE COUPE – ÉCAILLES SCHNITTPROBLEME - SPLITTER	Piastrelle che si scheggiano, scagliano, rompono durante il taglio lineare e/o foratura quadrangolare e/o circolare. / Tiles that chip, flake or break when straight cuts or rectangular/round holes are made in the tile. / Carreaux qui s'ébrèchent, s'écaillent et se brisent durant la coupe linéaire et/ou la perforation quadrangulaire et/ou circulaire. / Fliesen, die beim geraden Zuschnitt und/oder dem Anbringen von quadratischen und/oder kreisförmigen Bohrungen brechen.	/

Tabella 3 - Vizi occulti / Table 3 – hidden defects / Tableau 3 – vices cachés / Tabelle 3 - verborgene mängel

CAUSALE / TYPE OF DEFECT / MOTIF / GRUND	DESCRIZIONE / DESCRIPTION / DESCRIPTION / DESCRIPTION / BESCHREIBUNG	ECCEZIONI / EXCEPTIONS / EXCEPTIONS / AUSNAHMEN
CREPE - SCATOLONI - SFILATO CRACKS – BLISTERING CRAQUELURES – DÉCROCHAGES SUPERFICIELS RISSE - ABBLÄTTERN	Piastrelle che successivamente alla posa manifestano crepe parallele o ortogonali al bordo oppure superficiali ("scatolone"). / Tiles which (after laying) present cracks that run parallel or orthogonally to the edge or surface cracks ("blistering"). / Carreaux qui, après la pose, manifestent des craquelures parallèles ou orthogonales sur leur bord ou leur surface (« décrochage superficiel »). / Fliesen, die nach der Verlegung Risse parallel oder orthogonal zur Kante oder oberflächliche Risse („abplatzende Hohlstellen“) aufweisen.	Attenzione perché le rotture delle piastrelle tagliate per il perimetro della pavimentazione, il più delle volte, sono conseguenza di mancati accorgimenti nel taglio e/o nella posa della ceramica. / Great care should be taken when cutting and laying ceramic tiles around edges and other objects, as breakages are often due to the failure to take appropriate precautions. / Attention car les ruptures des carreaux coupés pour le périmètre du sol, le plus souvent, sont la conséquence d'un manque de précautions au moment de la coupe et/ou la pose de la céramique. / Gehen Sie mit dem Material vorsichtig um, denn der Bruch der Fliesen, die für den Bodenbelag zugeschnitten wurden geht meistens auf mangelnde Aufmerksamkeit beim Schneiden und/oder Verlegen zurück.
CAVILLO TARDIVO SUBSEQUENT CRACKLING TRESSAILLAGE À EFFET RETARDÉ SPÄTERE HAARRISSE	Piastrelle smaltate da rivestimento che manifestano fenomeni di cavillo "tardivo" dopo alcuni mesi dalla posa in opera. / Glazed wall tiles on which the phenomenon of crackling starts to appear "subsequently", even several months after laying. / Carreaux émaillés pour revêtement qui présentent des phénomènes de tressailage « à effet retardé », quelques mois après la pose. / Emaillierte glasierte Wandfliesen, die wenige Monate nach der Verlegung Haarrisse zeigen.	Questo difetto può essere dovuto alla ceramica ma il più delle volte alla posa non eseguita "a regola d'arte". / This defect may be due to the ceramic product, but is normally caused by improper laying of the tiles. / Ce défaut peut être dû à la céramique mais il est le plus souvent dû à la pose qui n'a pas été réalisée dans « les règles de l'art ». / In diesen Fällen kann die Keramik mangelhaft sein, aber meistens gehen diese Probleme auf die nicht „fachmännisch“ durchgeführte Verlegung zurück.
DANNEGGIAMENTO DA GELO FROST DAMAGE DÉTERIORATION DUE AU GEL FROSTSCHÄDEN	Piastrelle che dopo alcuni mesi dalla posa in esterno mostrano la comparsa di fratture e scagliature abbastanza tipiche della ceramica, il più delle volte di tipo "concoide". / Tiles laid outside that start to show fractures and flaking typical of ceramic tiles, often of the "conchoidal" type. / Carreaux qui, quelques mois après la pose en extérieur, montrent l'apparition de fractures et d'écaillés assez typiques de la céramique, le plus souvent de type « conchoïde ». / Fliesen, bei denen einige Monate nach der Verlegung Brüche oder - meist muschelförmige - Absplitterungen auftreten, wie sie recht typisch für Keramik sind.	Il distacco e/o sollevamento di piastrelle posate in esterno come pure la rottura di piastrelle singole e/o adiacenti fra loro non è da imputare alla ceramica ma ad una errata installazione. / If tiles laid outdoors become detached from the substrate or raised, or if individual and/or adjacently laid tiles break, this is not due to the ceramic product but to incorrect laying. / Le détachement et/ou soulèvement de carreaux posés à l'extérieur ainsi que la rupture de carreaux individuels et/ou placés les uns à côté des autres ne sont pas dus à la céramique mais à une installation incorrecte. / Das Ablösen und/oder Abheben von im Außenbereich verlegten Fliesen sowie der Bruch einzelner und/oder benachbarter Fliesen ist nicht auf die Keramik, sondern auf eine fehlerhafte Verlegung zurückzuführen.

CAUSALE / TYPE OF DEFECT / MOTIF / GRUND / DEFECTO / ПРИЧИНА	DESCRIZIONE / DESCRIPTION / DESCRIPTION / DESCRIPTION / BESCHREIBUNG / DESCRIPCIÓN / ОПИСАНИЕ	ECCEZIONI / EXCEPTIONS / EXCEPTIONS / AUSNAHMEN / EXCEPCIONES / ИСКЛЮЧЕНИЯ
MACCHIABILITA' INCLINATION TO STAINS SALISSURE FLECKENEMPFINDLICHKEIT	Piastrelle che trattengono in modo anomalo lo sporco e risultano essere di difficile pulibilità. / Tiles that trap dirt to an excessive extent and are difficult to clean. / Carreaux qui retiennent de manière anormale la saleté et s'avèrent être difficiles à nettoyer. / Fliesen, die Schmutz auf ungewöhnliche Weise zurückhalten und schwer zu reinigen sind.	Verosimilmente si tratta di un difetto occulto ma c'è da verificare se è dovuto a prestazioni inadeguate del materiale ceramico installato e/o errata manutenzione del cliente finale. / This is probably due to a hidden defect, but it is also necessary to check if this is due to insufficient characteristics of the tile used for the purpose, and/or incorrect maintenance on the part of the end customer. / Il s'agit vraisemblablement d'un vice caché mais il faut vérifier si celui-ci est dû à des prestations inadaptées du matériau céramique installé et/ou à un entretien incorrect effectué par le client final. / Es handelt sich wahrscheinlich um einen versteckten Mangel, aber es muss geprüft werden, ob er auf eine unzureichende Leistung des verlegten Materials und/oder eine fehlerhafte Pflege durch den Endkunden zurückzuführen ist.

NOTE

Le informazioni contenute in questo catalogo sono il più possibile esatte, ma non sono da ritenersi legalmente vincolanti. Ceramiche Supergres si riserva la facoltà di modificare in qualunque momento le informazioni e le caratteristiche dei prodotti presenti in questo catalogo.

Peso, colori e misure sono soggetti alle inevitabili variazioni tipiche del processo di cottura della ceramica. Tutti i formati sono nominali. Le conversioni in pollici sono approssimative e arrotondate.

I colori e le caratteristiche estetiche dei prodotti si avvicinano quanto più possibile a quelli reali nei limiti consentiti dai processi di stampa.

I consigli e le istruzioni date, pur essendo frutto di studi e di prove eseguite con la massima serietà, sono da ritenersi puramente indicative.

Le caratteristiche tecniche riportate su questo catalogo annullano e sostituiscono quelle indicate nel precedente catalogo generale.

NOTES

The informations contained in this catalogue is correct to the best of our knowledge, but is not to be construed as legally binding. Ceramiche Supergres reserves the right to change and modify the products listed in this catalogue at any time.

The governing sizes are the metric ones – measurements in inches are for only.

All sizes are nominal. Conversion of sizes in inches are approximate.

Weight, colour and sizes are subject to the usual variation expected in fired ceramic products.

Colours shown are as close to the real colours as the limitation of the printing process will allow. While being the result of carefully effected studies and tests, these suggestions and instructions should be considered purely indicative.

The technical features detailed on this catalogue replace and substitute all other features detailed in the previous general catalogue.

NOTES

Les renseignements contenus dans ce catalogue sont le plus possible exacts, mais ils ne sont sous la tutelle d'aucune jurisprudence.

Ceramiche Supergres se réserve le droit d'apporter à tout moment des modifications ou des variations aux produits de ce catalogue.

Les poids, coloris et mesures sont sujets à d'inévitables variations typiques au processus de cuisson de la céramique.

Tous les formats sont nominaux. Les conversions en pouces sont approximatives et arrondies.

Les couleurs indiquées sont fidèles dans le limites consenties par le procédés d'imprimerie. Les conseils et les données, tout en étant le résultat d'études et d'essais très soignés, doivent être considérés comme purement indicatifs.

Les caractéristiques techniques indiquées dans ce catalogue annulent et remplacent celles de notre précédent catalogue général.

ANMERKUNGEN

Die im vorliegenden Katalog enthaltenen Angaben sind so genau wie moeglich gehalten, sind aber rechtlich unverbindlich. Ceramiche Supergres behält sich das Recht vor jederzeit Änderungen oder Ergänzungen in Bezug auf die Produkte in diesem Katalog vorzunehmen.

Gewicht, Farbe und Ausmasse der Fliesen unterliegen der unumgaenglichen.

Toleranzen eines keramischen Ofenbrandes.

Alle Formate sind Nominalgrößen. Die Zoll-Konvertierungen sind geschätzt und gerundet.

Die abgebildeten Farben entsprechen innerhalb der drucktechnischen Grenzen der Wirklichkeit.

Die vorstehenden Anleitungen sind zwar das Ergebnis von Studien und Tests, die mit einem Höchstmaß an Seriosität durchgeführt wurden, aber dennoch nur als Orientierungswerte zu verstehen.

Die technischen Eigenschaften in diesem Katalog annullieren und ersetzen die im vorherigen Katalog.

SCOPRI DI PIÙ SUL MONDO **SUPERGRES** SEGUICI SUI NOSTRI CANALI SOCIAL

FIND OUT MORE ABOUT SUPERGRES WORLD. FOLLOW US ON
OUR SOCIAL NETWORKS

CERAMICHE
SUPERGRES



CERAMICHE SUPERGRES

© Copyright 2023 Ceramiche Supergres - Casalgrande (Reggio Emilia) - Italy
Pubblicato da Ceramiche Supergres - Strada Statale 467, n° 34 - 42013 Casalgrande (RE) Italy
Gennaio 2023
Progetto, direzione e coordinamento a cura dell'ufficio marketing Ceramiche Supergres

© Copyright 2023 by Ceramiche Supergres - Casalgrande (Reggio Emilia) - Italy
Published by Ceramiche Supergres - Strada Statale 467, n° 34 - 42013 Casalgrande (RE) Italy
January 2023
Project, management and co-ordination by marketing Ceramiche Supergres

Finito di stampare a Reggio Emilia nel mese di Febbraio 2023 per conto di Ceramiche Supergres
Strada Statale 467, n° 34 - 42013 Casalgrande (RE) Italy
I prodotti, i marchi e le immagini riprodotte nel presente catalogo sono tutelati ai sensi della normativa vigente in materia di proprietà intellettuale. Ogni violazione degli stessi verrà perseguita a norma di legge.

Printed in Reggio Emilia in the month of February 2023 on behalf of Ceramiche Supergres
Strada Statale 467, n° 34 - 42013 Casalgrande (RE) Italy
All products, trade-marks and photographs reproduced in this catalogue are subject to all existing intellectual property laws. Any breach thereof will be dealt with under the provisions provided by such law.

Ceramics of Italy

CERAMICHE
SUPERGRES
MADE in ITALY

