

# Cladding

2021



**“ dagli anni Novanta  
il nostro stile  
inconfondibile ”**

#imsostone

# IMSO design

Originalità e personalità  
Materiali ricercati  
Curiosità insaziabile  
Visione internazionale  
Passione italiana

#imsodesign

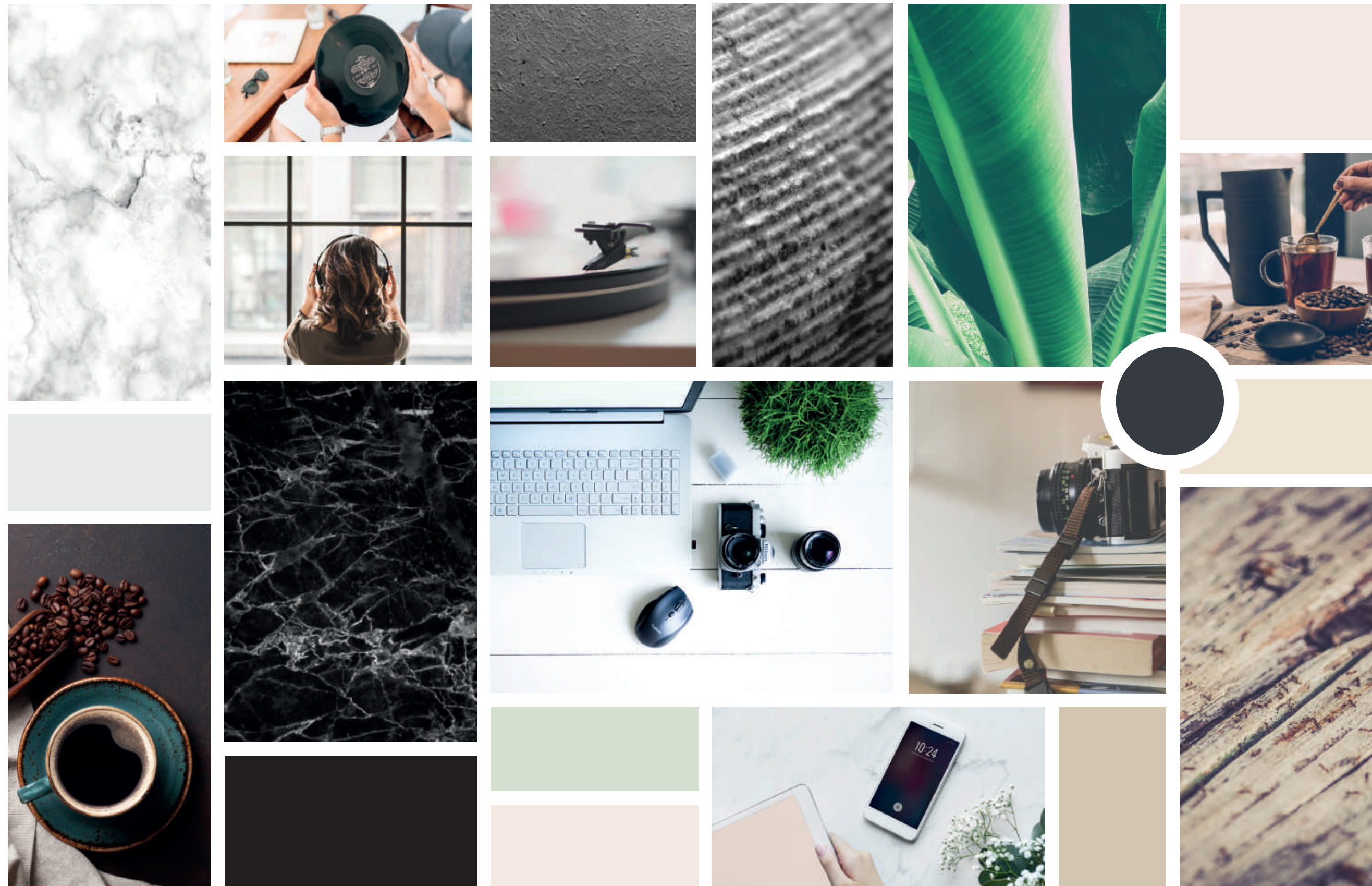

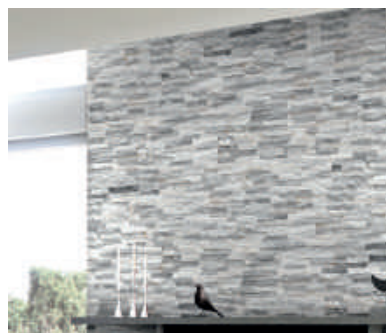
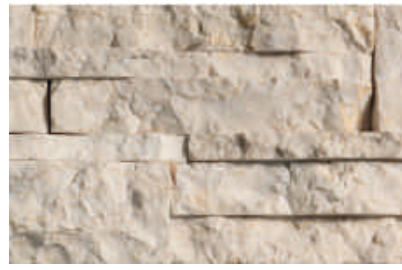

**Sezione  
CLADDING**

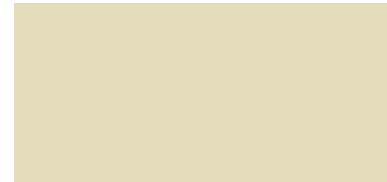

# CLADDING

caratteristiche  
prodotti  
imballi

TRAMEZZO

15x60 cm  
spessore 1-3 cm



DOLOMITI

15,2x61 cm  
spessore 3-4 cm



SPACCATELLO

10x35 cm  
0,7-1,5 cm

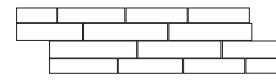

APPENNINI

15x45 cm  
spessore 1,5-3 cm

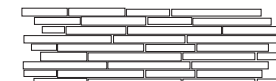

APUANE

15x40,5 cm



WOOD CLADDING

15x60 cm  
spessore 2-3 cm

Wood Cladding 4



Wood cladding 8

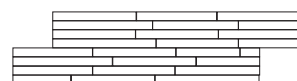

CROSS - Slate Cladding

15x45 cm  
spessore 1,5-3 cm

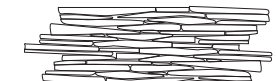

VEIN - Slate Cladding

15x45 cm  
spessore 1,5-3 cm

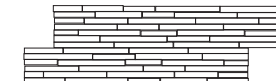

SQUARE - Slate Cladding

15x45 cm  
spessore 1,5-3 cm

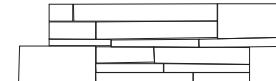

**Dolomiti**  
Multi  
15,2x61

**EcoTimber**  
Oak  
10x10

**TK**  
Antracite  
30x60



TRAMEZZO BIANCO	
CODE	ISCITRABC
DIMENSIONS	15x60 cm
Pz / Box	6
Mq / Box	0,54
Kg / Box	23,61
Box / Pal	36
Mq / Pal	19,44
Kg / Pal	850
PRICE BAND	6



SPACCATELLO BIANCO	
CODE	ISCISPABI
DIMENSIONS	10x35 cm
Pz / Box	8
Mq / Box	0,28
Kg / Box	7
Box / Pal	90
Mq / Pal	25,20
Kg / Pal	560
PRICE BAND	5

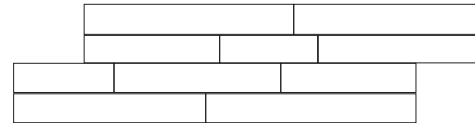
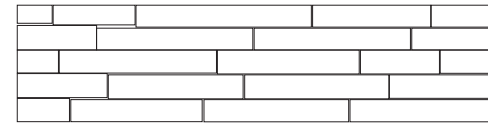

TRAMEZZO IVORY	
CODE	ISCITRAIV
DIMENSIONS	15x60 cm
Pz / Box	6
Mq / Box	0,54
Kg / Box	23,61
Box / Pal	36
Mq / Pal	19,44
Kg / Pal	850
PRICE BAND	6



APUANE BIANCO	
CODE	ISAPUABCO
DIMENSIONS	15x40,5
Pz / Box	8
Mq / Box	0,48
Kg / Box	50
Box / Pal	60
Mq / Pal	28,80
Kg / Pal	1440
PRICE BAND	9

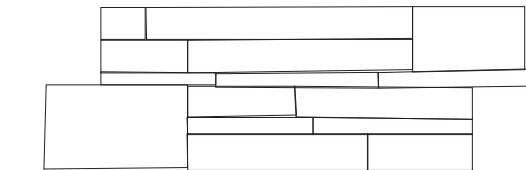

TRAMEZZO SNOW WHITE	
CODE	ISCITRASW
DIMENSIONS	15x60 cm
Pz / Box	6
Mq / Box	0,54
Kg / Box	23,61
Box / Pal	36
Mq / Pal	19,44
Kg / Pal	850
PRICE BAND	6



SPACCATELLO SNOW WHITE	
CODE	ISCISPASW
DIMENSIONS	10x35 cm
Pz / Box	8
Mq / Box	0,28
Kg / Box	7
Box / Pal	90
Mq / Pal	25,20
Kg / Pal	560
PRICE BAND	5

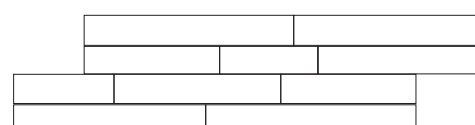
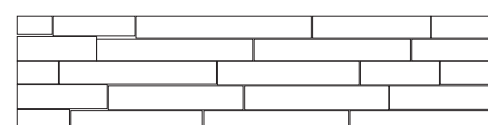

APPENNINI BIANCO	
CODE	ISAPPEBIA
DIMENSIONS	15x45 cm
Pz / Box	6
Mq / Box	0,40
Kg / Box	17,60
Box / Pal	60
Mq / Pal	24,00
Kg / Pal	1056
PRICE BAND	9



TRAMEZZO BEIGE	
CODE	ISCITRABE
DIMENSIONS	15x60
Pz / Box	6
Mq / Box	0,54
Kg / Box	23,61
Box / Pal	36
Mq / Pal	19,44
Kg / Pal	850
PRICE BAND	1

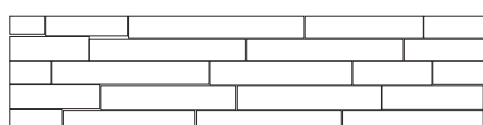
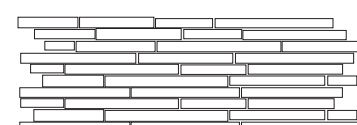

## SPACCATELLO BEIGE

CODE	ISCISPABE
DIMENSIONS	10x35 cm
Pz / Box	8
Mq / Box	0,28
Kg / Box	7
Box / Pal	90
Mq / Pal	25,20
Kg / Pal	560
PRICE BAND	0

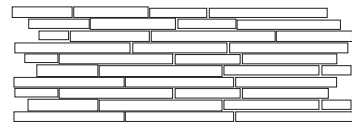

## APPENNINI BEIGE

CODE	ISAPPEBEI
DIMENSIONS	15x45 cm
Pz / Box	6
Mq / Box	0,40
Kg / Box	17,60
Box / Pal	60
Mq / Pal	24,00
Kg / Pal	1056
PRICE BAND	9

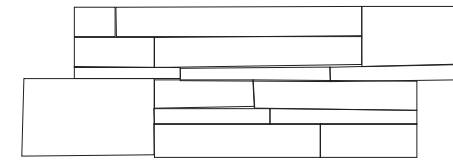

## APUANE BEIGE

CODE	ISAPUABGE
DIMENSIONS	15x40,5
Pz / Box	8
Mq / Box	0,48
Kg / Box	50
Box / Pal	60
Mq / Pal	28,80
Kg / Pal	1440
PRICE BAND	9

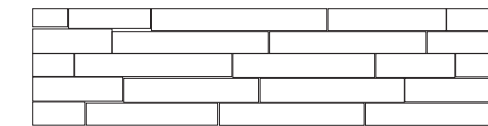

## TRAMEZZO MIX

CODE	ISCITRAMX
DIMENSIONS	15x60
Pz / Box	6
Mq / Box	0,54
Kg / Box	23,61
Box / Pal	36
Mq / Pal	19,44
Kg / Pal	850
PRICE BAND	1

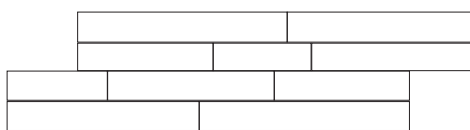

## TRAMEZZO GOLD

CODE	ISCITRAGO
DIMENSIONS	15x60 cm
Pz / Box	6
Mq / Box	0,54
Kg / Box	23,61
Box / Pal	36
Mq / Pal	19,44
Kg / Pal	850
PRICE BAND	6

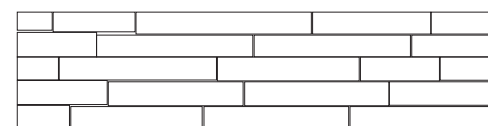

## SPACCATELLO GOLD

CODE	ISCISPAGO
DIMENSIONS	10x35 cm
Pz / Box	8
Mq / Box	0,28
Kg / Box	7
Box / Pal	90
Mq / Pal	25,20
Kg / Pal	560
PRICE BAND	0

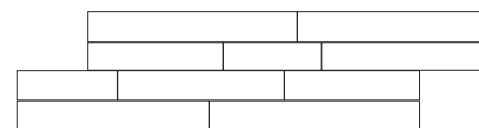

## DOLOMITI ROSSO

CODE	ISCIDOROS
DIMENSIONS	15,2x61,5
Pz / Box	4
Mq / Box	0,27
Kg / Box	26,64
Box / Pal	30
Mq / Pal	11,12
Kg / Pal	800,64
PRICE BAND	9

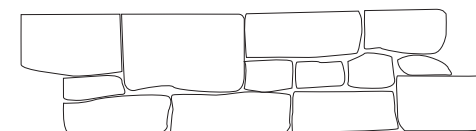

## DOLOMITI MULTI

CODE	ISCIDOMUL
DIMENSIONS	15,2x61,5
Pz / Box	4
Mq / Box	0,27
Kg / Box	26,64
Box / Pal	30
Mq / Pal	11,12
Kg / Pal	800,64
PRICE BAND	9

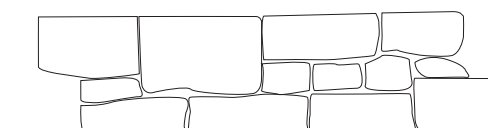





TRAMEZZO MULTI	
CODE	
DIMENSIONS	15x60 cm
Pz / Box	6
Mq / Box	0,54
Kg / Box	23,61
Box / Pal	36
Mq / Pal	19,44
Kg / Pal	850
PRICE BAND	1



SPACCATELLO MULTI	
CODE	
DIMENSIONS	10x35 cm
Pz / Box	8
Mq / Box	0,28
Kg / Box	7
Box / Pal	90
Mq / Pal	25,20
Kg / Pal	560
PRICE BAND	0

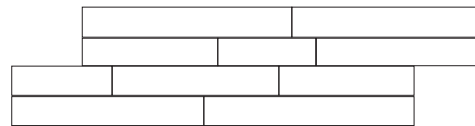
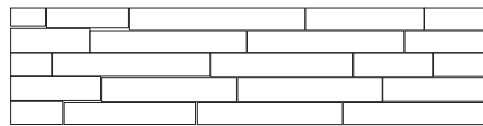

TRAMEZZO CLOUDY GREY	
CODE	ISCITRACG
DIMENSIONS	15x60 cm
Pz / Box	6
Mq / Box	0,54
Kg / Box	23,61
Box / Pal	36
Mq / Pal	19,44
Kg / Pal	850
PRICE BAND	2



CROSS SLATE	
CODE	ISWALCROS
DIMENSIONS	15x45
Pz / Box	16
Mq / Box	0,96
Kg / Box	21,12
Box / Pal	24
Mq / Pal	23,04
Kg / Pal	566,88
PRICE BAND	9

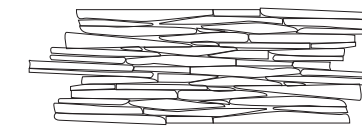
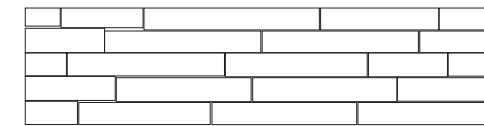

APPENNINI GRIGIO	
CODE	ISAPPEGRI
DIMENSIONS	15x45 cm
Pz / Box	6
Mq / Box	0,40
Kg / Box	17,00
Box / Pal	60
Mq / Pal	24,00
Kg / Pal	1056
PRICE BAND	9



APJANE GRIGIO	
CODE	ISAPUAGRI
DIMENSIONS	15x40,5
Pz / Box	8
Mq / Box	0,48
Kg / Box	50
Box / Pal	60
Mq / Pal	28,80
Kg / Pal	1440
PRICE BAND	9

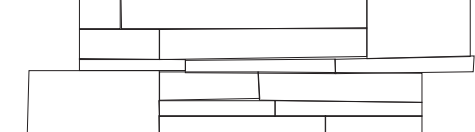
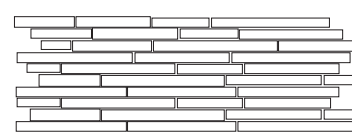

TRAMEZZO GRIGIO	
CODE	ISCITRAGR
DIMENSIONS	15x60 cm
Pz / Box	6
Mq / Box	0,54
Kg / Box	23,61
Box / Pal	36
Mq / Pal	19,44
Kg / Pal	850
PRICE BAND	6



DOLOMITI GRIGIO MIX	
CODE	ISCIDOGRI
DIMENSIONS	15,2x61,5
Pz / Box	4
Mq / Box	0,27
Kg / Box	26,64
Box / Pal	30
Mq / Pal	11,12
Kg / Pal	800,64
PRICE BAND	9

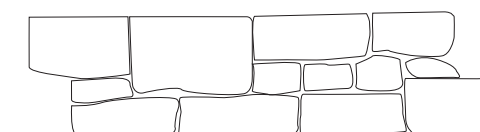
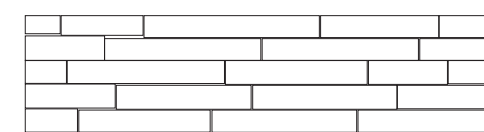



TRAMEZZO ANTIQUE	
CODE	ISCITRAAN
DIMENSIONS	15x60 cm
Pz / Box	6
Mq / Box	0,54
Kg / Box	23,61
Box / Pal	36
Mq / Pal	19,44
Kg / Pal	850
PRICE BAND	6

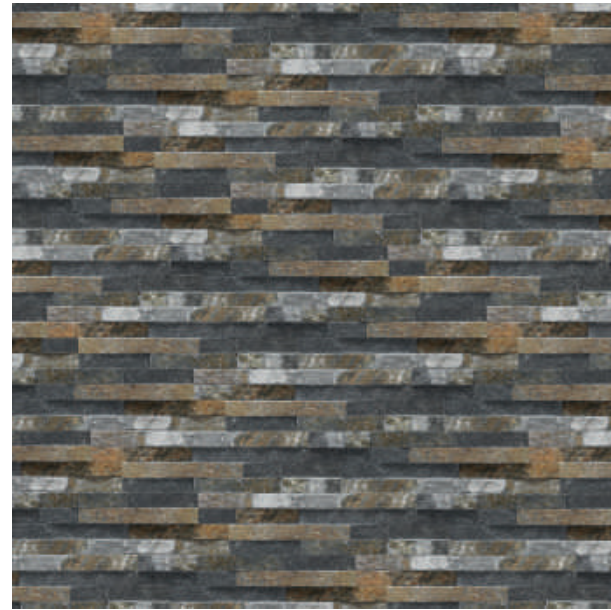

SPACCATELLO ANTIQUE	
CODE	ISCISPAAN
DIMENSIONS	10x35 cm
Pz / Box	8
Mq / Box	0,28
Kg / Box	7
Box / Pal	90
Mq / Pal	25,20
Kg / Pal	560
PRICE BAND	5

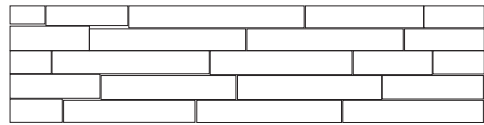

TRAMEZZO CEMENTO	
CODE	ISCITRACE
DIMENSIONS	15x60 cm
Pz / Box	6
Mq / Box	0,54
Kg / Box	23,61
Box / Pal	36
Mq / Pal	19,44
Kg / Pal	850
PRICE BAND	6



SPACCATELLO CEMENTO	
CODE	ISCISPACE
DIMENSIONS	10x35 cm
Pz / Box	8
Mq / Box	0,28
Kg / Box	7
Box / Pal	90
Mq / Pal	25,20
Kg / Pal	560
PRICE BAND	5

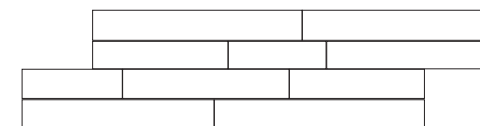
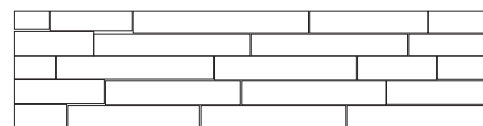

SQUARE SLATE	
CODE	ISWALSQUA
DIMENSIONS	15x45 cm
Pz / Box	16
Mq / Box	0,96
Kg / Box	21,12
Box / Pal	24
Mq / Pal	23,04
Kg / Pal	506,88
PRICE BAND	9



APPENNINI NERO	
CODE	ISAPPENER
DIMENSIONS	15x45
Pz / Box	6
Mq / Box	0,40
Kg / Box	17,60
Box / Pal	60
Mq / Pal	24
Kg / Pal	1056
PRICE BAND	9

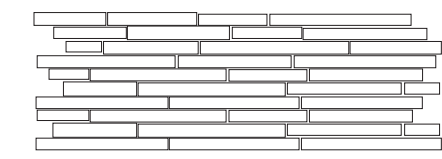
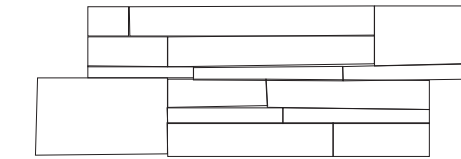

APUANE NERO	
CODE	ISAPUANER
DIMENSIONS	15x40,5
Pz / Box	8
Mq / Box	0,48
Kg / Box	50
Box / Pal	60
Mq / Pal	28,80
Kg / Pal	1440
PRICE BAND	9



VEIN SLATE	
CODE	ISWALVEIN
DIMENSIONS	15x45 cm
Pz / Box	16
Mq / Box	0,96
Kg / Box	21,12
Box / Pal	24
Mq / Pal	23,04
Kg / Pal	506,88
PRICE BAND	9

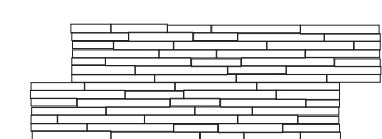
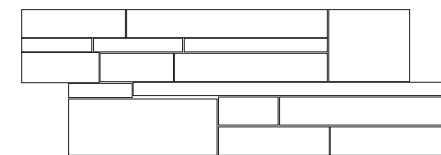



TRAMEZZO NERO

CODE	ISCITRANE
DIMENSIONS	15x60 cm
Pz / Box	6
Mq / Box	0,54
Kg / Box	23,61
Box / Pal	36
Mq / Pal	19,44
Kg / Pal	850
PRICE BAND	1



SPACCATELLO NERO

CODE	ISCISPANE
DIMENSIONS	10x35 cm
Pz / Box	8
Mq / Box	0,28
Kg / Box	7
Box / Pal	90
Mq / Pal	25,20
Kg / Pal	560
PRICE BAND	0

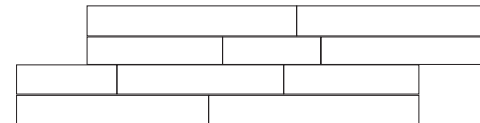
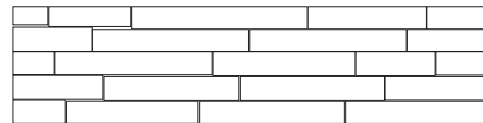

TRAMEZZO ANTRACITE

CODE	ISCITRAAT
DIMENSIONS	15x60 cm
Pz / Box	6
Mq / Box	0,54
Kg / Box	23,61
Box / Pal	36
Mq / Pal	19,44
Kg / Pal	850
PRICE BAND	9



SPACCATELLO ANTRACITE

CODE	ISCISPAAT
DIMENSIONS	10x35 cm
Pz / Box	8
Mq / Box	0,28
Kg / Box	7
Box / Pal	90
Mq / Pal	25,20
Kg / Pal	560
PRICE BAND	7

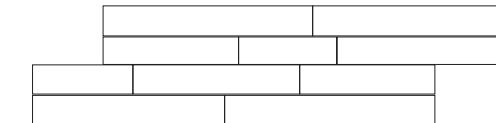
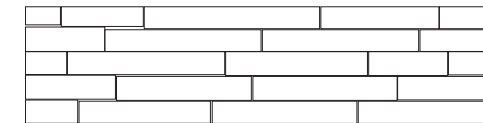

TRAMEZZO DARK

CODE	ISCITRABL
DIMENSIONS	15x60 cm
Pz / Box	6
Mq / Box	0,54
Kg / Box	23,61
Box / Pal	36
Mq / Pal	19,44
Kg / Pal	850
PRICE BAND	6



TRAMEZZO BLACK FOREST

CODE	ISCITRABF
DIMENSIONS	15x60 cm
Pz / Box	6
Mq / Box	0,54
Kg / Box	23,61
Box / Pal	36
Mq / Pal	19,44
Kg / Pal	850
PRICE BAND	9

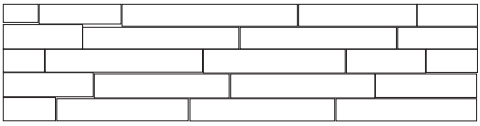
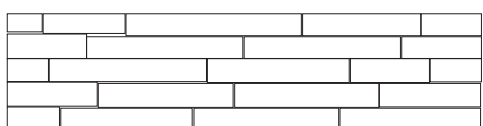

TRAMEZZO CORNER

15x60 / 15x15 cm  
spessore 1,5-3 cm

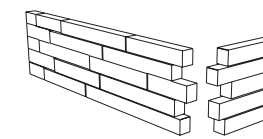

DOLOMITI CORNER

15x30 cm / 15x30 cm  
spessore 3-4 cm

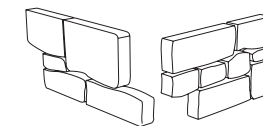

CODICE	ARTICOLO	PRICE BAND	PZ/BOX	KG/PZ	BOX/PAL	KG/BOX	KG/PAL
ISCITRABS	BIANCO TRAMEZZO ANGOLO	8	4	4,92	36	16,98	708,48
ISCITRASI	IVORY TRAMEZZO ANGOLO	8	4	4,92	36	16,98	708,48
ISCITRASB	BEIGE TRAMEZZO ANGOLO	7	4	4,92	36	16,98	708,48
ISCITRASX	MIX TRAMEZZO ANGOLO	7	4	4,92	36	16,98	708,48
ISCITRASM	MULTI TRAMEZZO ANGOLO	7	4	4,92	36	16,98	708,48
ISCITRASY	CLOUDY GREY TRAM.ANGOLO	8	4	4,92	36	16,98	708,48
ISCITRASG	GRIGIO TRAMEZZO ANGOLO	8	4	4,92	36	16,98	708,48
ISCITRASC	CEMENTO TRAMEZZO ANGOLO	8	4	4,92	36	16,98	708,48
ISCITRASN	NERO TRAMEZZO ANGOLO	8	4	4,92	36	16,98	708,48
ISCITRASF	BLACK FOREST TRAM. ANGOLO	8	4	4,92	36	16,98	708,48
ISCITRASD	DARK TRAMEZZO ANGOLO	8	4	4,92	36	16,98	708,48
ISCITRASH	GOLD TRAMEZZO ANGOLO	8	4	4,92	36	16,98	708,48
ISCITRASA	ANTIQUE TRAM.ANGOLO	8	4	4,92	36	16,98	708,48
ISCITRAST	ANTRACITE TRAM ANGOLO	8	4	4,92	36	16,98	708,48
ISCITRASS	SNOW WHITE TRAM ANG.	8	4	4,92	36	16,98	708,48
ISCIDOANR	DOLOMITI ROSSO ANGOLO	8	4	3,33	30	11,12	333,60
ISCIDOANM	DOLOMITI MULTI ANGOLO	8	4	3,33	30	11,12	333,60
ISCIDOANG	DOLOMITI GRIGIO MIX ANGOLO	8	4	3,33	30	11,12	333,60



NATURAL 4	
CODE	ISWCLNAT4
DIMENSIONS	15x60 cm
Pz / Box	10
Mq / Box	0,90
Kg / Box	9,00
Box / Pal	50
Mq / Pal	45,00
Kg / Pal	450,00
PRICE BAND	9

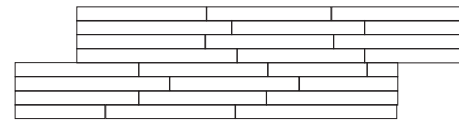

NATURAL 8	
CODE	ISWCLNAT8
DIMENSIONS	15x60 cm
Pz / Box	10
Mq / Box	0,90
Kg / Box	9,00
Box / Pal	50
Mq / Pal	45,00
Kg / Pal	450,00
PRICE BAND	9

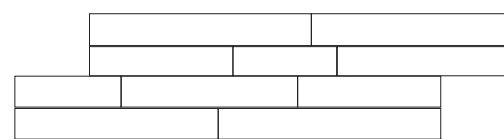

EROSION 4	
CODE	ISWCLERO4
DIMENSIONS	15x60 cm
Pz / Box	10
Mq / Box	0,90
Kg / Box	9,00
Box / Pal	50
Mq / Pal	45,00
Kg / Pal	450,00
PRICE BAND	9

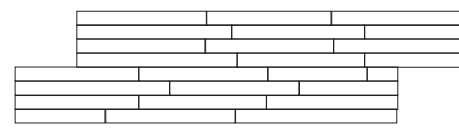

EROSION 8	
CODE	ISWCLERO8
DIMENSIONS	15x60 cm
Pz / Box	10
Mq / Box	0,90
Kg / Box	9,00
Box / Pal	50
Mq / Pal	45,00
Kg / Pal	450,00
PRICE BAND	9

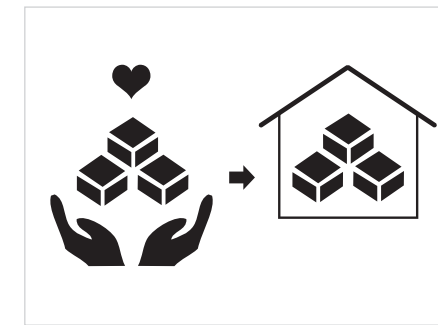

## STEP 1

Maneggiare le scatole con cura e tenere in ambienti chiusi;  
Handle boxes with care and store in indoor;  
Manipuler les boites avec soin et garder les en ambiente ferme;  
Die Kartons mit vorsichtigem Umgang bewegen und in Innenraeumen halten.



## STEP 2

Per risultati migliori immagazzinare nel nuovo ambiente le scatole per almeno una settimana;  
Store Panels in the new environment for at least one week;  
Pour obtenir meilleurs résultat stocker les boites dans le nouveau ambiente pour au moins une semaine;  
Um bessere Ergebnisse zu erhalten, die Kartons eine Woche frueher in der neuen Umgebung platzieren.

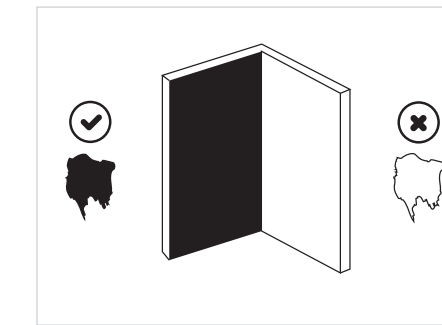

## STEP 3

Raccomandiamo la posa su una parete scura;  
We recommende the installation on a dark wall;  
Nous raccomandons la pose sur une mure foncé;  
Wir empfehlen die Verlegung auf einer dunklen Wand.

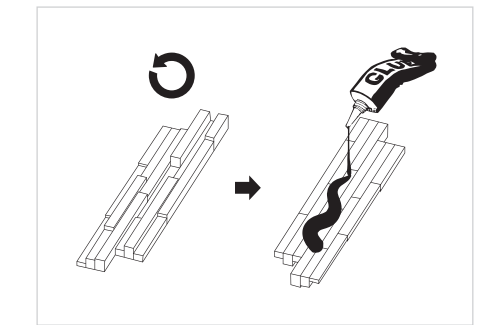

## STEP 4

Per ottenere risultati migliori consigliamo l'uso di un sigillante a base di MS POLIMER pm;  
For better result we recommende to use adesive MS POLIMER pm;  
Pour un meilleur résultat est recommandé l'utilisation d'un adhésif MS POLIMER pm;  
Um bessere Ergebnisse zu erhalten, empfehlen wir die Benutzung eines Klebers MS POLIMER pm.

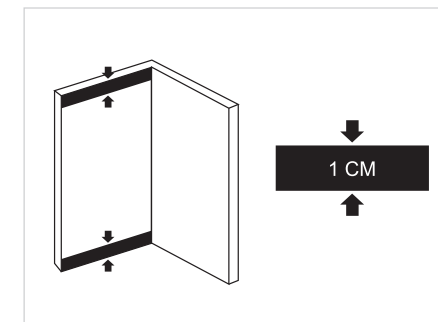

## STEP 5

Durante l' installazione raccomandiamo di tenere le placche ad 1 cm. dal pavimento e 1 cm. dal soffitto;  
During installation we recommend to keep the sheet 1 cm from the floor and 1 cm from the plafond;  
Pendant l' installation est recommandé de tenir les plaques a 1 cm du sol et 1 cm du plafond;  
Waherend der Installierung, empfieln wir die Plaques auf einem Cm. vom Boden und auf einem Cm. vom Decke zu halten.

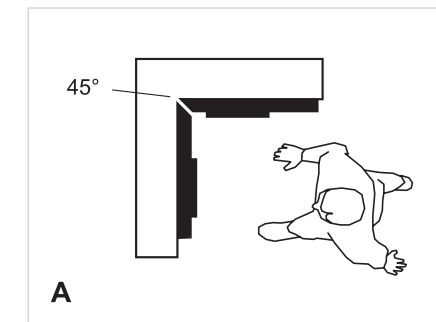

## CORNER SOLUTIONS - A

Consigli di posa per gli angoli;  
Corner solutions;  
Conseille de pose pour les angles;  
Verlegungshinweisungen fuer ecken.

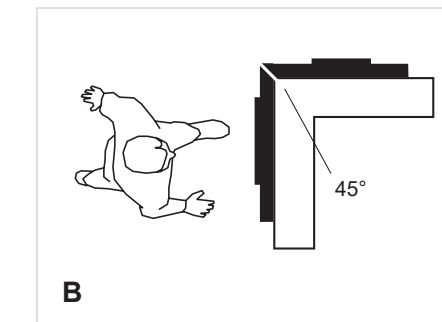
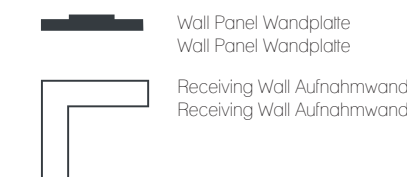

## CORNER SOLUTIONS - B

Consigli di posa per gli angoli;  
Corner solutions;  
Conseille de pose pour les angles;  
Verlegungshinweisungen fuer ecken.

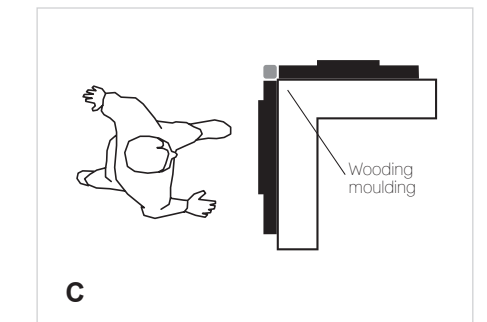
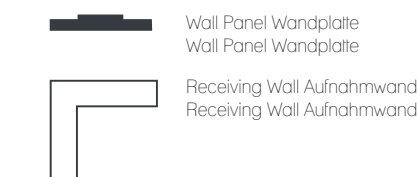

## CORNER SOLUTIONS - C

Consigli di posa per gli angoli;  
Corner solutions;  
Conseille de pose pour les angles;  
Verlegungshinweisungen fuer ecken.

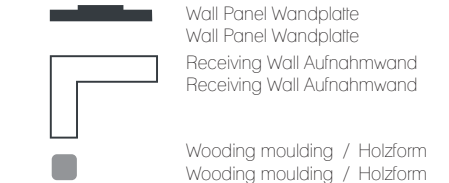



CREAM TEAK  
Crema di cera d'api per teak

Flacone 250 ml €6,50 / pz  
Prezzo netto Net price Prix net Netto preis

CODE: TEAKCREAM



PRIMER TEAK 30  
Idrorepellente concentrato per rivestimenti in teak

Flacone 250 ml €15,00 / pz  
Prezzo netto Net price Prix net Netto preis

CODE: TEAKPRIME

CREAM TEAK è una cera liquida, morbida e ricca di cera d'api, a base d'acqua, per la finitura di superfici in legno naturale come il teak, precedentemente protetto con PRIMER TEAK 30.

CREAM TEAK fa risaltare tutta la bellezza naturale delle superfici, ravvivandole e mantenendole nel tempo. Penetra nelle fibre del legno e, usato regolarmente, nutre, protegge e favorisce la pulizia delle superfici rendendole antistatiche alla polvere.

MODALITA' D'USO: Prodotto pronto all'uso. Applicare a pennello un velo leggero di prodotto e uniformare. A superficie asciutta lucidare con spazzola o con panno di lana. Resa: 2 mq con 250 ml.

CREAM TEAK est une émulsion liquide, douce et riche à la cire d'abeille, à base d'eau, pour la finition des surfaces en bois naturel comme le teak, précédemment protégé avec PRIMER TEAK 30. CREAM TEAK redonne toute la beauté naturelle des surfaces en le ravivant, et le maintient dans le temps.

Elle pénètre dans les fibres du bois et, utilisée régulièrement, nourrit, protège et favorise le nettoyage des surfaces en le rendant antistatique à la poussière.

EMPLOI: Produit prêt à l'usage. Appliquer au pinceau un voile léger de produit et uniformiser. Lorsque la surface est sèche, nettoyer avec une brosse ou un chiffon en laine. Réappliquer périodiquement si nécessaire. Rendement: 2 m2 avec 250 ml.

CREAM TEAK is a liquid, soft, water-based beeswax for natural wood and teak surfaces, already protected with PRIMER TEAK 30.

CREAM TEAK helps revive and keep during the time the natural beauty of wood surfaces, penetrates the woods fibers and usually used feeds, protects and helps keep the surfaces cleaned and antistatic.

INSTRUCTIONS: CREAM TEAK is ready for use. Apply with a paintbrush a uniform light part of product. On dry surface polish with woolen cloth or brush.

Yield: 2 sqm/250 ml.

CREAM TEAK ist ein flüssiges Wachs, weich und reich von Bienenwachs. Auf Wasserbasis fuer die Endbearbeitung von natuerlichen Holzoberflaechen wie Teak, zuvor geschuetzt mit PRIMER TEAK 30. CREAM TEAK verherrlicht die natuerliche Schoenheit der Oberflaechen und behaltet sie im Laufe der Zeit bei. Es penetriert in die Fasern des Holzes und wenn es regelmaessig verwendet wird, noehrt, schuetzt und erleichtert die Reinigung der Oberflaechen damit sie antistatischem dem Staub werden.

VERWENDUNG: Das Produkt ist Gebrauchsfertig. Mit einem Pinsel eine dünne Schicht des Produktes anwenden. Bei glaenzender Oberflaeche mit einem Pinsel oder Wolltuch polieren. Ausbeute: 2 Qm mit 250,00 Ml.

PRIMER TEAK 30, base acqua, è un prolettivo idrorepellente di nuova generazione nanotecnologia per legno. PRIMER TEAK 30 non altera la traspirazione, non pellicola ed è particolarmente indicato per rivestimenti in teak.

MODALITA' D'USO: Agitare prima dell'uso. PRIMER TEAK 30 è concentrato. Diluire in acqua 1:5 - 1:6 e applicare la soluzione a temperatura ambiente, su superfici spolverate e asciutte. Uniformare con pennello. A superficie asciutta applicare CREAM TEAK.

AVVERTENZA: Teme il gelo (stoccare a temperatura minima +5°C); non esporre al sole. Durante l'applicazione aver cura di tirare bene il prodotto in modo uniforme. Resa: 3-4 mq/L di diluito.

PRIMER TEAK 30, à base d'eau, est une protection hydrofuges de nouvelle génération nano technologique pour bois. PRIMER TEAK 30 laisse respirer le revêtement, ne forme pas de film et est particulièrement indiqué pour les revêtements en teak.

EMPLOI : agiter avant l'emploi. PRIMER TEAK 30 est concentré (1 flacon de 250ml pour obtenir 1,5 litre de prêt à l'usage). Délayer à l'eau 1:5 et appliquer la solution à température ambiante, sur surfacés épousés et secs. Uniformiser avec le pinceau. A surface sec appliquer CREAM TEAK.

AVERTISSEMENT: stocker à température minime de +5°C ; ne pas exposer au soleil.

Appliquer le produit de façon uniforme jusqu'à saturation de revêtement. Rendement: 3-4 m2 par main dilué.

PRIMER TEAK 30, water-based, is a waterproof protection of new generation, for wood.

Primer Teak 30 does not disfigure the wood transpiration, does not make film and is particularly indicated for wood claddings.

INSTRUCTIONS: Shake well before using. Primer teak 30 is concentrate. Dilute with water 1:5-1:6 and apply product at room temperature, on dry and clean surfaces. Uniform with a brush. After, just on dry surfaces apply Cream Teak.

WARNING: Primer teak 30 does not tolerate the frost. (Stock at +5°C temperature) Do not expose to sunlight. Have care to apply the product uniformly. Yield: 3-4 sqm/Lt. Already diluted product.

PRIMER TEAK 30, auf Wasserbasis ist ein Wasserabweisender Schuetz einer neuen Generation der Nanotechnologien des Holzes. PRIMER TEAK aendert nicht die Traspiration, erzeugt keinen Film und ist besoders fuer Teak Beschichtungen empfohlen.

VERWENDUNG: Vor Gebrauch schuetkeln. PRIMER TEAK 30 ist konzentriert. Im Wasser verduennen: 1:5 - 1:6 dann die Loesung beim Raumtemperatur auf bestaeuble und trockene Oberflaechen anwenden. Dann uniform mit einem Pinsel verbreiten.

WARNUNG: Frostgefah , bei einer Tiefsttemperatur von (+5 C) immer behalten. Nicht in die Sonne aussetzen. Waehrend der Anwendung das Produkt gut und gleichmaessig verbreiten. Ausbeute: 3-4 Qm/L vom verwaessertem Material.

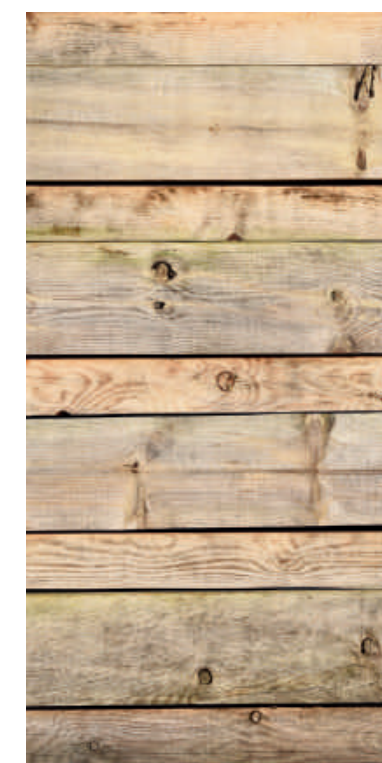
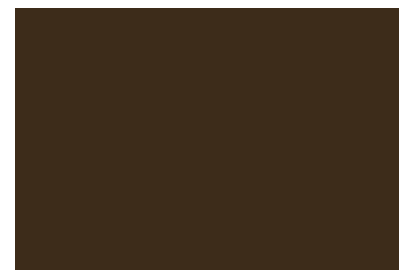

## CONDIZIONI GENERALI DI VENDITA

### 1 - APPLICABILITY OF CONDITIONS

1.1 These general conditions (the "CONDITIONS") constitute the most important part of each contract of sale of tiles and any other ceramic material (the "PRODUCTS") in which IMSO CERAMICHE (the MANUFACTURER) is one of the parties. Excepted single cases in which they have been derogated by explicitly written agreements signed by the MANUFACTURER, they will constitute the exclusive discipline of such sales. If one or more parts of these CONDITIONS, or of single contracts including them, result to be invalid, the general or the particular CONDITIONS will remain valid as a whole: invalid parts will be substituted through agreements that are as close as possible to the original will of the parties.

### 2 - CONCLUSION OF THE CONTRACT OF SALE - DELIVERY

2.1. The contract is intended to be concluded at the moment in which the written consent of the counterpart has come to the knowledge of the proponent and of the person ordering the contract.  
2.2. The order that has not been confirmed in writing cannot be considered accepted in any case, except for the performance of the contract itself by the MANUFACTURER through shipment or delivery of the PRODUCTS. The partial delivery of ordered PRODUCTS doesn't involve that the whole order has been accepted, but only that part of PRODUCTS actually delivered.  
2.3. Except a different written agreement, the delivery of PRODUCTS in Italy or abroad will take place "ex-works".  
2.4. Except a different agreement, all the dates given as delivery dates are intended in a indicative sense.

### 3 - CHARACTERISTICS OF THE PRODUCTS - WARRANTY - COMPLAINTS

3.1. Ceramic tiles and other ceramic PRODUCTS produced by IMSO CERAMICHE comply with European norms UNI-DIN-EN. The MANUFACTURER sells exclusively to professional resellers that are responsible for the accuracy of technical informations given to final users and/or to retailers.

The classification of a product is indicated by the MANUFACTURER on advertising material and/or on price lists. Therefore the purchaser must use the PRODUCTS according to the classification given by the MANUFACTURER. To facilitate the directions for the use of products and to adapt standard classifications to the specificity of the production, marks connected with each single product are put in price lists and catalogues, indicating the specific use advised by the MANUFACTURER.

3.2. Differences in the tone are not defects of the PRODUCT but a characteristic of the specific material fired at high temperatures. The particular requisite of frost resistance is applied only to those PRODUCTS explicitly guaranteed by the MANUFACTURER with the relative indication on advertising material and/or price list. In case this indication is not given, ceramic materials are considered only and exclusively for indoor use or use in places protected from bad weather.

3.3. Ceramic materials with polished surface can never be used in places located on the ground floor with access outside or in places with great pedestrian traffic. In addition polished tiles are susceptible for a certain slipperiness especially when they are wet. The MANUFACTURER advises therefore not to use them in public places. In places with great pedestrian traffic the purchase will have to buy only those PRODUCTS classified by the MANUFACTURER as PEI V, and in particular those tiles that the MANUFACTURER advises SPECIFICALLY for use in public places.

3.4. The pictures of the PRODUCTS on leaflets and on other advertising material by the PRODUCER are only illustrative and they don't represent necessarily the final esthetic result of laying of the PRODUCT.

3.5. The MANUFACTURER guarantees the good quality and the absence of defects of the products supplied, the warranty is not applied to those PRODUCTS classified by the MANUFACTURER as non-first-quality products or to lots of PRODUCTS of the end of a series, sold in bulk and pointed out as special lots. However a 5% tolerance is provided.

3.6. The MANUFACTURER is not responsible for defects and/or anomalies found out in the PRODUCTS that are not due to their quality, but to an improper use of them by the purchasers and/or by their assignees. In particular the MANUFACTURER doesn't accept complaints or contestations concerning the above mentioned situation.

3.7. Complaints must be communicated by the purchaser to the MANUFACTURER within 8 days from the delivery of goods. In case of defects, the term is 8 days from the discovery. In any case the MANUFACTURER is not responsible for the defects denounced 12 months after the delivery of the PRODUCTS to the purchaser. In case of hidden defects the warranty is applied up to 2 years after the delivery of the PRODUCTS to the first purchaser. The denunciation of defects must be notified to the MANUFACTURER within and not later than 8 days from the discovery.

3.8. In general the warranty is applied only for defects found out in products that have not yet been layed. In case of hidden defects, detectable only after laying, it's necessary for the MANUFACTURER to verify that the laying has been carried out duly (conforming to DIN 18352).

3.9. The MANUFACTURER's warranty is limited to the substitution of faulty PRODUCTS with other products of the same model without defects, freight included. The reimbursement of other expenses or additional costs, and in particular demolition costs and money paid for a second laying of the PRODUCTS is excluded. In any case the MANUFACTURER's warranty cannot exceed 5 times the value of the contested material, with an absolute maximum of 10.000 euro.

3.10. The MANUFACTURER is not responsible for complaints due to a classification of the ceramic material by foreign bodies for control and/or certification, that is different from the Italian one, according to technical specifications that don't correspond to those used by the MANUFACTURER. In case of technical expertise activated by the purchaser, this must be necessarily based on the conformity of the sold material with the specifications indicated by the MANUFACTURER in force in Italy.

### 4 - PRICES AND CONDITIONS OF PAYMENT

4.1. The sale prices of PRODUCTS are those indicated in the price list of the MANUFACTURER in force at the moment of the confirmation of the order. In case of contracts of sale and delivery of goods divided in parts, and if there is no written agreement. On the subject, the price is the one indicated in the price list in force at the moment of the delivery of each single portion of goods. For all the PRODUCTS destined to the foreign market prices can be calculated at MANUFACTURER's choice in the foreign currency of the destination country or in Italian lire.

Every bank and negotiation costs have to be debted to the Purchaser. In case of delay in the payment the MANUFACTURER has the right, without the necessity of putting into mora to cash a moratory interest amounting to the official discount rate in Italy, plus 5%, apart from economical damages occurred.

### 5 - MANUFACTURER'S AGENTS

5.1. The MANUFACTURER's agents promote sales but are not authorized to act in the name and on the behalf of the MANUFACTURER, except in case of a specific written permission.

5.2. The orders transmitted by the agents don't bind the MANUFACTURER. Therefore they must be accepted explicitly in writing by the MANUFACTURER.

### 6 - RESERVED DOMINION

6.1. It's agreed between the parties that the sale of the PRODUCTS is carried out with reserve of propriety in favour of the MANUFACTURER up to the total payment of the agreed price, according to the Italian Civil Code, art. 1523 and following. However the risk of deterioration of the goods passes to the purchaser from the moment of delivery of the PRODUCTS. In the sales of the PRODUCTS abroad, in case the goods are sold and delivered to third customers before the transfer of title, within the ordinary trade relations of the purchaser himself, the reserve of property in favour of the MANUFACTURER remains also towards third customers, when the law permits it.

6.2. In case of mora of the Purchaser, the MANUFACTURER can take back all the goods object of reserved dominion without any formality, included the putting into mora, and if the law permits it, all documents of credit to third people relative to these goods, with reserve of any proper legal remedy for the prejudices suffered.

### 7 - SUPERIOR FORCE

7.1. The MANUFACTURER is not responsible towards the Purchaser for non-fulfillment, included non-delivery or delay in delivery due to events outside his reasonable control, as for example non-delivery or delay in delivery of materials by the suppliers, breakdown of plants, strikes or other sindical actions, interruption of energy supply, interruption or difficulty of transports.

### 8 - APPLICABLE LAW - COMPETENT COURTS

8.1. The contracts of sale to export in which the MANUFACTURER is one of the party are governed by the Italian law and in particular by the "Preservation of International Contracts of Sale" of movables, where it's not derogated by these CONDITIONS and by the Convention of Vienna (11 April 1 980).

8.2 The competent court for any controversy concerning the sale of the PRODUCTS by the MANUFACTURER and the trade relation connected with the above mentioned sales is the court of the registered office of the MANUFACTURER, even when the legal action started concerns documents of credit released to the MANUFACTURER, as means of payment.

IMSO  
CERAMICHE